INTERNATIONAL STANDARD



3228

INTERNATIONAL ORGANIZATION FOR STANDARDIZATION • МЕЖДУНАРОДНАЯ ОРГАНИЗАЦИЯ ПО СТАНДАРТИЗАЦИИ • ORGANISATION INTERNATIONALE DE NORMALISATION

Rolling bearings — Bearings with spherical outside surface and extended inner ring width — Cast and pressed housings

*Roulements — Roulements à surface extérieure sphérique et à bague intérieure large —
Paliers moulés et paliers emboutis*

iTeh STANDARD PREVIEW

Second edition — 1977-11-15

(standards.iteh.ai)

[ISO 3228:1977](#)

<https://standards.iteh.ai/catalog/standards/sist/011fcf2d-a944-4722-a363-b289c7f3f0f8/iso-3228-1977>

UDC 621.822.6

Ref. No. ISO 3228-1977 (E)

Descriptors : rolling bearings, bearings, dimensions.

FOREWORD

ISO (the International Organization for Standardization) is a worldwide federation of national standards institutes (ISO member bodies). The work of developing International Standards is carried out through ISO technical committees. Every member body interested in a subject for which a technical committee has been set up has the right to be represented on that committee. International organizations, governmental and non-governmental, in liaison with ISO, also take part in the work.

Draft International Standards adopted by the technical committees are circulated to the member bodies for approval before their acceptance as International Standards by the ISO Council.

International Standard ISO 3228 was drawn up by Technical Committee ISO/TC 4, *Rolling bearings*. This second edition incorporates the text of draft Addendum 1, which was circulated to the member bodies in September 1976.

This Addendum has been approved by the member bodies of the following countries :

Australia	Germany	Spain
Belgium	Hungary	Sweden
Brazil	Italy	Switzerland
Bulgaria	Korea, Rep. of	United Kingdom
Canada	Netherlands	U.S.S.R.
Chile	Poland	Yugoslavia
Czechoslovakia	Romania	
France	South Africa, Rep. of	

<https://standards.iteh.ai/catalog/standards/sist/011fcf2d-a944-4722-a363-b289c7f340f8/iso-3228-1977>

The member body of the following country expressed disapproval of the document on technical grounds :

Japan

This second edition cancels and replaces the first edition (i.e. ISO 3228-1974) which had been approved by the member bodies of the following countries :

Austria	Italy	Turkey
Brazil	Netherlands	United Kingdom
Czechoslovakia	Poland	U.S.A.
France	Spain	U.S.S.R.
Germany	Sweden	Yugoslavia
Hungary	Switzerland	
India	Thailand	

It had also been approved by the International Union of Railways (UIC).

The member bodies of the following countries had expressed disapproval of the document on technical grounds :

Australia
Japan
Romania

Rolling bearings – Bearings with spherical outside surface and extended inner ring width – Cast and pressed housings

iTeh STANDARD PREVIEW (standards.iteh.ai)

1 SCOPE AND FIELD OF APPLICATION

This International Standard specifies boundary dimensions for cast and pressed housings for rolling bearings with spherical outside surface and extended inner ring width for which boundary dimensions are given in ISO 2264, *Rolling bearings – Bearings with spherical outside surface and extended inner ring width*. For the cast housings, tolerances are also given.

It deals with plummer block housings, flanged housings and take-up housings. The inclusion of relubrication features is optional, but when provided they should intersect the zone specified in ISO 2264 in such a way that lubricant will satisfactorily feed from the housing through this zone. The exact design of the relubrication features is not otherwise controlled by this International Standard.

2 SYMBOLS AND DIMENSIONS

The symbols shown in the figures and given in the tables denote nominal dimensions.

Where "max." is shown in the tables, this indicates that the value is both the largest nominal and the largest actual value permitted.

Where "min." is shown in the tables, this indicates that the value is both the smallest nominal and the smallest actual value permitted.

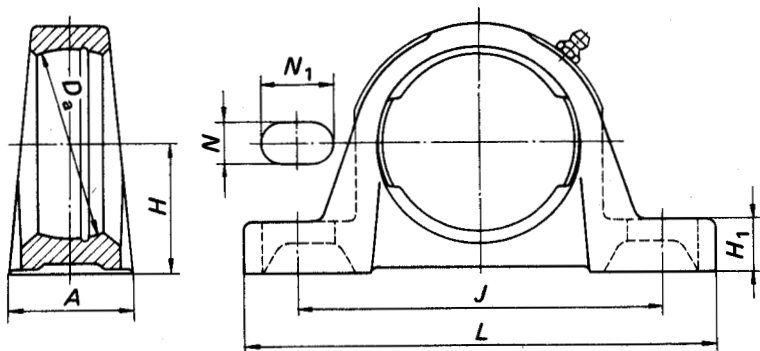

TABLE 1 – Cast plummer block housings

Dimensions in millimetres

D_a	L max.	A max.	J	H_1 max.	H $\pm IT 12$	N min.	N_1 min.
40	128	39	96	16	30,2	11,5	16
47	128	39	96	16	33,3	11,5	16
52	140	39	105	17	36,5	11,5	16
62	166	48	121	19	42,9	14	19
72	167	48	126	20	47,6	14	19
80	185	55	136	20	49,2	14	19
85	191	55	146	22	54	14	19
90	207	61	159	23	57,2	18	20,5
100	220	61	172	25	63,5	18	20,5
110	242	71	186	27	69,9	18	22

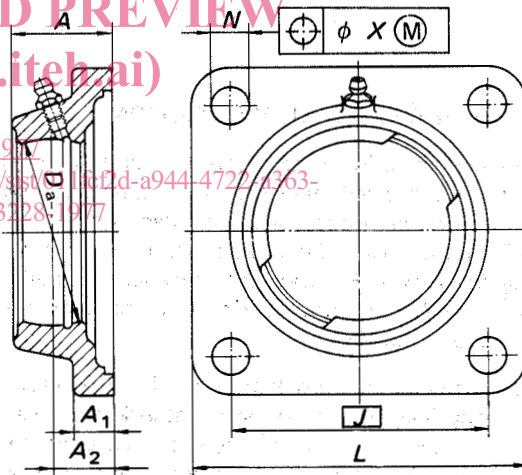

TABLE 2 – Cast flanged housings, square

Dimensions in millimetres

D_a	L max.	A max.	J	A_1 max.	A_2	N min.	X
40	77	28	54	13	17	11,5	0,6
47	86	34	63,5	15	19	11,5	0,6
52	96	35	70	15	19	11,5	0,6
62	109	38	82,5	16	20	11,5	0,6
72	118	38	92	17	21	14	0,8
80	131	42	101,5	17	24	14	0,8
85	137	42	105	18	24	16	0,8
90	144	46	111	20	28	18	0,8
100	163	50	130	21	31	18	0,8
110	175	55	143	21	34	18	0,8

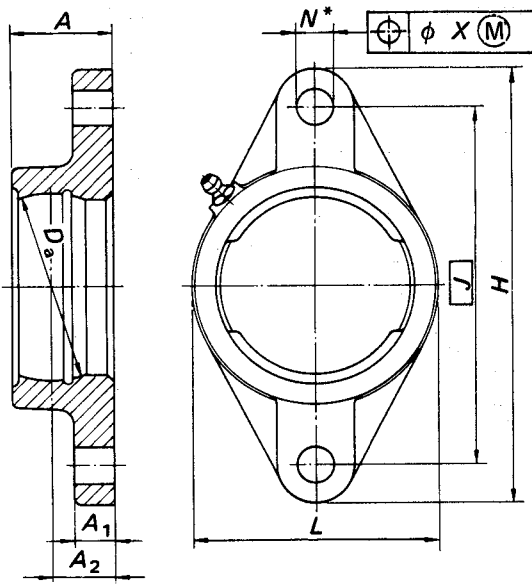

TABLE 3 – Cast flanged housings, oval

Dimensions in millimetres
 IT-1 STANDARD PREVIEW
 (standards.iteh.ai)

D_a	H max.	L max.	A max.	J	A_1 max.	A_2	N^* min.	X
40	99	57	28	76,5	13	17	11,5	0,6
47	113	61	34	90	15	19	11,5	0,6
52	125	70	35	99	15	19	11,5	0,6
62	142	83	38	116,5	16	20	11,5	0,6
72	156	96	38	130	17	21	14	0,8
80	172	105	42	143,5	17	24	14	0,8
85	180	111	42	148,5	18	24	16	0,8
90	190	116	46	157	20	28	18	0,8
100	217	134	50	184	21	31	18	0,8
110	235	138	55	202	21	34	18	0,8

* The hole may alternatively be square with the side equal to N .

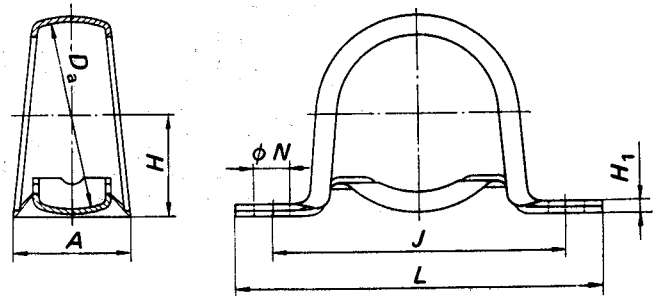

TABLE 4 – Pressed plummer block housings

Dimensions in millimetres

D_a	L max.	A max.	J	H_1 max.	H	N
40	86	26	68	3,5	22,2	9,5
47	99	32	76	3,5	25,4	9,5
52	108	32	86	4	28,6	11,5
62	119	38	95	4	33,3	11,5
72	130	41	106	5	39,7	11,5
80	148	43	120	5	43,7	13
85	156	45	128	6	46,8	13

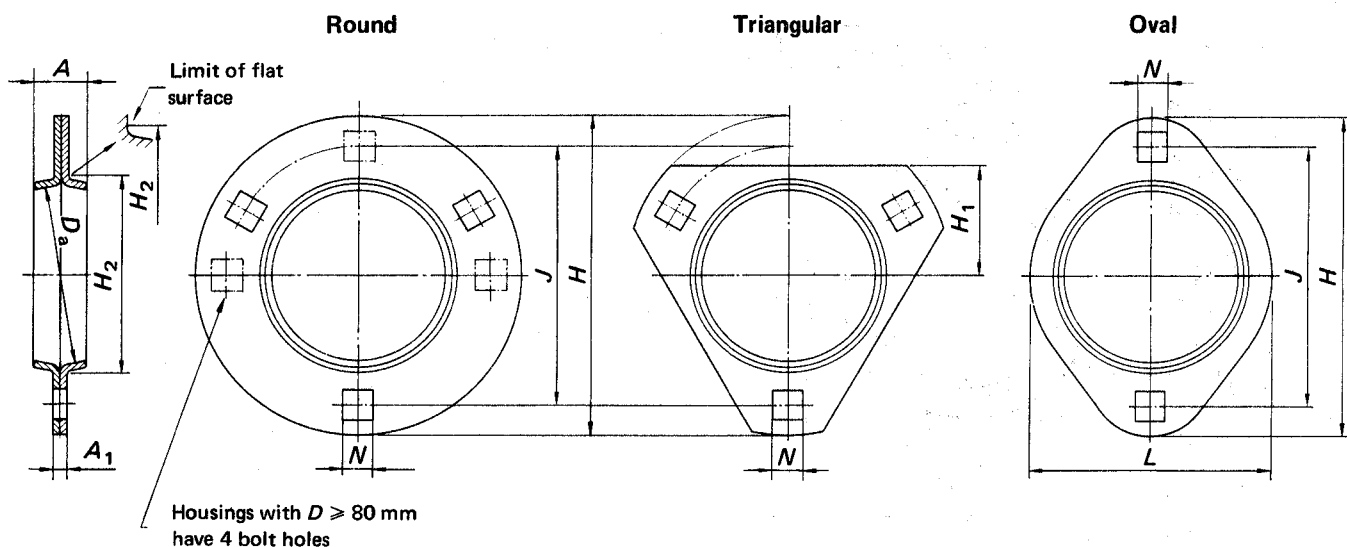

TABLE 5 — Pressed flanged housings :
Round, triangular and oval

iTeh STANDARD PREVIEW

Dimensions in millimetres

D_a	H max.	L max.	A max.	J	A_1 max.	H_1 max.	H_2 max.	N
40	81	59	15	63,5	4	29	49	7,1
47	91	67	16	71,5	4,5	34	55	8,7
52	96	71	18	76	4,5	35	60	8,7
62	113	85	20	90,5	5,5	41	71	10,5
72	123	94	21	100	5,5	45	81	10,5
80	148	—	23	119	7	—	91	13,5
85	150	—	23	120,5	7	—	97	13,5
90	156	—	25	127	8	—	102	13,5
100	167	—	26	138	8	—	113	13,5

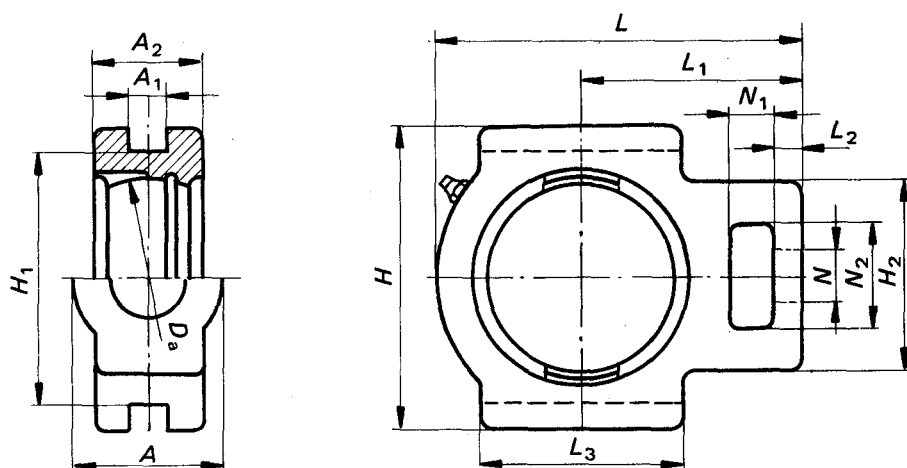

TABLE 6 – Cast take-up housings

Dimensions in millimetres

D_a	A max.	$A_1^{1)}$ max.	A_2 max.	H max.	$H_1^{2)}$ max.	H_2 max.	L max.	L_1 max.	L_2 min.	L_3 max.	N min.	N_1 min.	N_2 min.
47	51	13,5	34	94	76	64	104	68	9	59	18	15	31
52	51	13,5	34	94	76	64	104	68	9	59	18	15	31
62	51	13,5	38	107	89	66	118	73	9	65	19	15	36
72	53	13,5	38	107	89	66	130	78	10	72	19	15	36
80	67	17,5	44	124	101	84	146	91	14	84	27	18	48
85	67	17,5	44	124	101	84	148	91	14	84	27	18	48
90	67	17,5	48	124	101	84	152	92	14	88	27	18	48
100	72	27	52	151	130	102	191	120	17	104	34	25	63
110	72	27	54	151	130	102	195	120	17	104	34	31	63

1) Tolerance for the dimension A_1 is :

for diameter D_a up to and including 90 mm : $+0,5$
 $-0,25$ mm

for diameter $D_a = 100$ mm and 110 mm : $+1,0$
 $-0,25$ mm

2) Tolerance for the dimension H_1 is $\pm 0,25$ mm.

iTeh STANDARD PREVIEW
(standards.iteh.ai)

ISO 3228:1977

<https://standards.iteh.ai/catalog/standards/sist/011fcf2d-a944-4722-a363-b289c7f3f0f8/iso-3228-1977>