**Test conditions for vertical internal
type broaching machines — Testing of
accuracy**

*Conditions d'essai des machines verticales à brocher les intérieurs —
Contrôle de l'exactitude*

iTeh Standards
(<https://standards.iteh.ai>)
Document Preview

[ISO 6779:2023](https://standards.iteh.ai/catalog/standards/sist/bc1b2887-8d30-4364-8a82-e39071ac996d/iso-6779-2023)

<https://standards.iteh.ai/catalog/standards/sist/bc1b2887-8d30-4364-8a82-e39071ac996d/iso-6779-2023>



iTeh Standards
(<https://standards.iteh.ai>)
Document Preview

[ISO 6779:2023](https://standards.iteh.ai/catalog/standards/sist/bc1b2887-8d30-4364-8a82-e39071ac996d/iso-6779-2023)

<https://standards.iteh.ai/catalog/standards/sist/bc1b2887-8d30-4364-8a82-e39071ac996d/iso-6779-2023>



COPYRIGHT PROTECTED DOCUMENT

© ISO 2023

All rights reserved. Unless otherwise specified, or required in the context of its implementation, no part of this publication may be reproduced or utilized otherwise in any form or by any means, electronic or mechanical, including photocopying, or posting on the internet or an intranet, without prior written permission. Permission can be requested from either ISO at the address below or ISO's member body in the country of the requester.

ISO copyright office
CP 401 • Ch. de Blandonnet 8
CH-1214 Vernier, Geneva
Phone: +41 22 749 01 11
Email: copyright@iso.org
Website: www.iso.org

Published in Switzerland

Contents

| | Page |
|---|-----------|
| Foreword..... | iv |
| 1 Scope | 1 |
| 2 Normative references | 1 |
| 3 Terms and definitions | 1 |
| 4 Terminology and designation of axes | 2 |
| 5 Preliminary remarks | 3 |
| 5.1 Measurement units..... | 3 |
| 5.2 Reference to the ISO 230 series..... | 3 |
| 5.3 Testing sequence..... | 4 |
| 5.4 Tests to be performed..... | 4 |
| 5.5 Tolerances and minimum tolerance..... | 4 |
| 5.6 Measuring instruments..... | 4 |
| 6 Geometric tests | 5 |
| 7 Machining tests | 16 |
| Annex A (informative) Terms in other languages | 17 |
| Bibliography | 18 |

iTeh Standards
(<https://standards.itih.ai>)
Document Preview

[ISO 6779:2023](https://standards.itih.ai/catalog/standards/sist/bc1b2887-8d30-4364-8a82-e39071ac996d/iso-6779-2023)

<https://standards.itih.ai/catalog/standards/sist/bc1b2887-8d30-4364-8a82-e39071ac996d/iso-6779-2023>

Foreword

ISO (the International Organization for Standardization) is a worldwide federation of national standards bodies (ISO member bodies). The work of preparing International Standards is normally carried out through ISO technical committees. Each member body interested in a subject for which a technical committee has been established has the right to be represented on that committee. International organizations, governmental and non-governmental, in liaison with ISO, also take part in the work. ISO collaborates closely with the International Electrotechnical Commission (IEC) on all matters of electrotechnical standardization.

The procedures used to develop this document and those intended for its further maintenance are described in the ISO/IEC Directives, Part 1. In particular, the different approval criteria needed for the different types of ISO document should be noted. This document was drafted in accordance with the editorial rules of the ISO/IEC Directives, Part 2 (see www.iso.org/directives).

ISO draws attention to the possibility that the implementation of this document may involve the use of (a) patent(s). ISO takes no position concerning the evidence, validity or applicability of any claimed patent rights in respect thereof. As of the date of publication of this document, ISO had not received notice of (a) patent(s) which may be required to implement this document. However, implementers are cautioned that this may not represent the latest information, which may be obtained from the patent database available at www.iso.org/patents. ISO shall not be held responsible for identifying any or all such patent rights.

Any trade name used in this document is information given for the convenience of users and does not constitute an endorsement.

For an explanation of the voluntary nature of standards, the meaning of ISO specific terms and expressions related to conformity assessment, as well as information about ISO's adherence to the World Trade Organization (WTO) principles in the Technical Barriers to Trade (TBT), see www.iso.org/iso/foreword.html.

This document was prepared by Technical Committee ISO/TC 39, *Machine Tools*, Subcommittee SC 2, *Test conditions for metal cutting machine tools*. [ISO 6779:2023](https://standards.iso.org/iso-6779-2023)

<https://standards.iso.org/iso-6779-2023>
This third edition cancels and replaces the second edition (ISO 6779:2019), which has been technically revised.

The main changes are as follows:

- the French terms have been moved from [Figures 1](#) and [2](#) to [Tables A.1](#) and [A.2](#);
- subclause 5.7 on axes not under test has been deleted;
- the observations in all geometrical tests have been updated.

Any feedback or questions on this document should be directed to the user's national standards body. A complete listing of these bodies can be found at www.iso.org/members.html.

Test conditions for vertical internal type broaching machines — Testing of accuracy

1 Scope

This document specifies, with reference to ISO 230-1, the geometric tests on vertical internal type broaching machines with vertical Z-axis providing the main cutting motion.

This document also specifies the applicable tolerances corresponding to the tests mentioned above for normal-accuracy vertical internal type broaching machines.

This document explains the concepts, configurations and common features of vertical internal type broaching machines. This document also provides related terminology and designation of axes.

This document covers only the verification of the accuracy of the broaching machine. This document does not apply to the operational testing of the machine (e.g. vibration, abnormal noise, stick-slip motion of components) nor to machine characteristics (e.g. speeds, feeds) as such checks are generally carried out before testing the accuracy.

2 Normative references

The following documents are referred to in the text in such a way that some or all of their content constitutes requirements of this document. For dated references, only the edition cited applies. For undated references, the latest edition of the referenced document (including any amendments) applies.

ISO 230-1:2012, *Test code for machine tools — Part 1: Geometric accuracy of machines operating under no-load or quasi-static conditions*

3 Terms and definitions

For the purposes of this document, the terms and definitions given in ISO 230-1 and the following apply.

ISO and IEC maintain terminology databases for use in standardization at the following addresses:

— ISO Online browsing platform: available at <https://www.iso.org/obp>

— IEC Electropedia: available at <https://www.electropedia.org/>

3.1

internal broaching operation

machining process in which a *broach* (3.2) is pushed or pulled through a hole to remove material by linear cutting

3.2

broach

cutting tool that has multiple transverse cutting edges each with progressively increased size

3.3

broaching machine

machine tool in which broaching operation is executed

3.4 vertical internal type broaching machine

vertical *broaching machine* (3.3) in which its *broach* (3.2) is pushed or pulled through a hole inside of the workpiece to remove material

Note 1 to entry: A vertical broaching machine is understood to be a broaching machine whose main cutting axis (Z-axis) is vertical.

4 Terminology and designation of axes

Terminology and designation of axes are given in [Figures 1](#) and [2](#).

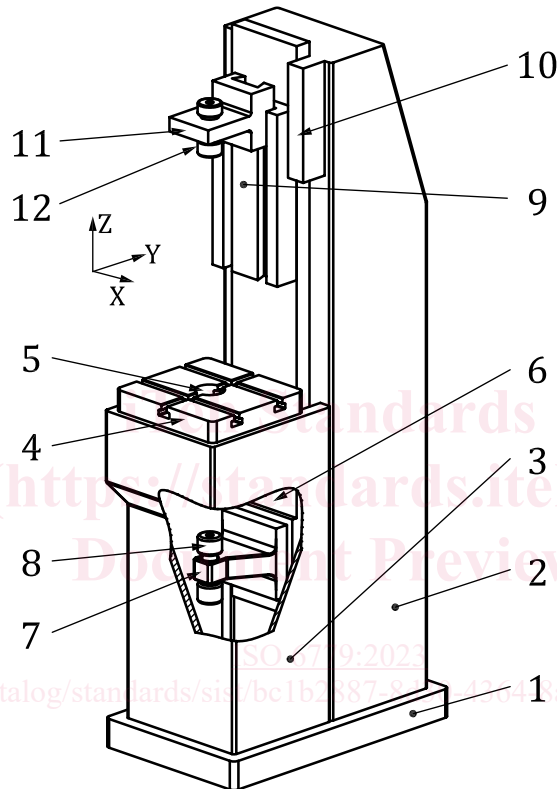

Key

- | | |
|--------------------------|-----------------------------|
| 1 bed | 7 pulling block |
| 2 column | 8 pulling chuck |
| 3 table base | 9 retrieving slide (W-axis) |
| 4 work table | 10 retrieving slide guide |
| 5 table centre bore | 11 retrieving block |
| 6 pulling slide (Z-axis) | 12 retrieving chuck |

NOTE For terms in French, Italian and Persian, see [Table A.1](#).

Figure 1 — Typical example of a vertical internal type broaching machine

A common configuration of vertical internal type broaching machines is table-up or push-type, which is illustrated in [Figure 2](#).

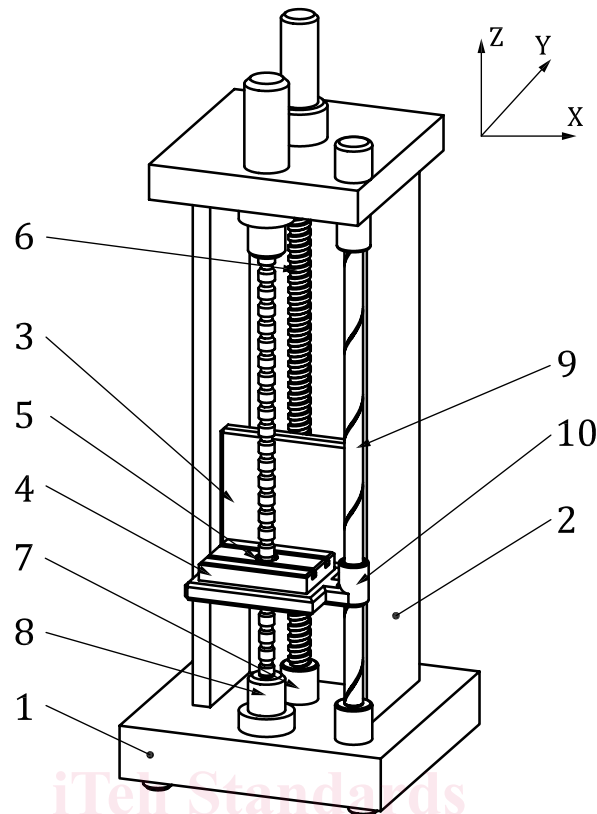
**Key**

| | | | |
|---|---------------------|----|---------------------|
| 1 | bed | 6 | table pushing screw |
| 2 | column | 7 | push screw rest |
| 3 | table base (Z-axis) | 8 | broach chuck |
| 4 | work table | 9 | Z-axis guide |
| 5 | table centre bore | 10 | Z-axis bush bearing |

NOTE For terms in French, Italian and Persian, see [Table A.2](#).

Figure 2 — Typical example of a table-up (push-type) vertical internal broaching machine

5 Preliminary remarks

5.1 Measurement units

In this document, all linear dimensions, deviations and corresponding tolerances are expressed in millimetres and angular dimensions are expressed in degrees. Angular deviations and the corresponding tolerances are expressed in ratios as the primary method. However, in some cases, microradians or arcseconds may be used for clarification purposes. [Formula \(1\)](#) should be used for conversion of the units of angular deviations or tolerances:

$$0,010 / 1\,000 = 10 \mu\text{rad} \approx 2'' \quad (1)$$

5.2 Reference to the ISO 230 series

To apply this document, reference shall be made to ISO 230-1, especially for the installation and levelling of the machine before testing, warming up of the moving components, description of measuring methods and recommended uncertainty of testing equipment.

In the “Observations” block of the tests described in [Clauses 6](#) and [7](#), the instructions are followed by a reference to the corresponding clause in ISO 230-1:2012, in cases where the test concerned is in line with the specifications of ISO 230-1.

5.3 Testing sequence

The sequence in which the tests are presented in this document does not define the practical order of testing. In order to make the mounting of instruments or gauging easier, tests may be performed in any order.

5.4 Tests to be performed

Prior to conducting tests on a vertical internal type broaching machine tool, the machine tool should be levelled according to the recommendations of the manufacturer/supplier (see ISO 230-1:2012, 6.1.2).

When testing a machine tool, it is not always necessary or possible to carry out all the tests described in this document. When the tests are required for acceptance purposes, it is up to the user to choose, in agreement with the manufacturer/supplier, those tests relating to the components and/or the properties of the machine tool which are of interest. These tests are to be clearly stated when ordering a machine tool. A mere reference to this document for the acceptance tests, without specifying the tests to be carried out, and without agreement on the relevant expenses, cannot be considered as binding for any contracting party.

5.5 Tolerances and minimum tolerance

In this document, all tolerance values (see ISO 230-1:2012, 4.1) are guidelines. When they are used for acceptance purposes, other values can be agreed between the user and the manufacturer/supplier. The required/agreed tolerance values are to be clearly stated when ordering the machine.

When establishing the tolerance for a measuring length different from that given in this document (see ISO 230-1:2012, 4.1.2), the minimum value of tolerance of 0,010 mm shall be considered.

5.6 Measuring instruments

Measuring instruments indicated in the tests described in [Clauses 6](#) and [7](#) are examples only. Other instruments capable of measuring the same quantities and having the same or a smaller measurement uncertainty may be used. Reference shall be made to ISO 230-1:2012, Clause 5, which indicates the relationship between measurement uncertainties and tolerances.

When a “dial gauge” is referred to, it can mean dial test indicators (DTIs) as well as any type of linear displacement sensor, such as analogue or digital dial gauges, linear variable differential transformers (LVDTs), linear scale displacement gauges, or non-contact sensors, when applicable to the concerned test (see ISO 230-1:2012, Clause 4).

Similarly, when a “straightedge” is referred to, it can mean any type of straightness reference artefact, such as a granite, ceramic, steel, or cast iron straightedge, one arm of a square, one generating line on a cylindrical square, any straight path on a reference cube, or a special, dedicated artefact manufactured to fit in the T-slots or other references.

In the same way, when a “square” is mentioned, it can mean any type of squareness reference artefact, such as granite, ceramic, steel or cast-iron square, a cylindrical square, a reference cube, or, again, a special, dedicated artefact.

6 Geometric tests

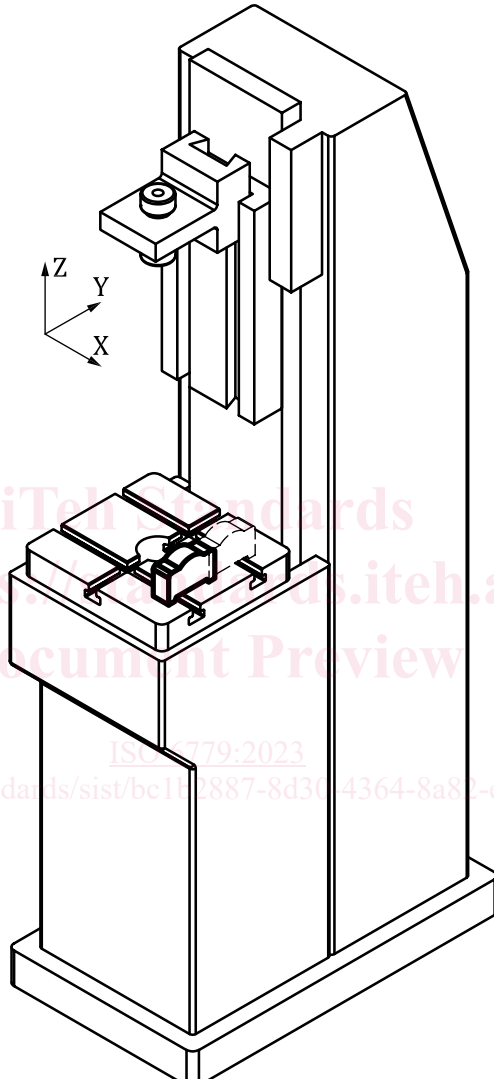
| | |
|---|-----------|
| Object Checking of flatness of the work table. | G1 |
| Diagram  | |
| Tolerance 0,040 for a measuring length of up to 1 000. | |
| Measured deviation | |
| Measuring instruments Precision level. | |
| Observations and references to ISO 230-1:2012, 12.2.4 Measurements shall be carried out at a number of positions equally spaced with measuring distance, <i>d</i> . For more details and interpretation of obtained results, refer to ISO 230-1:2012, 12.2.4. | |

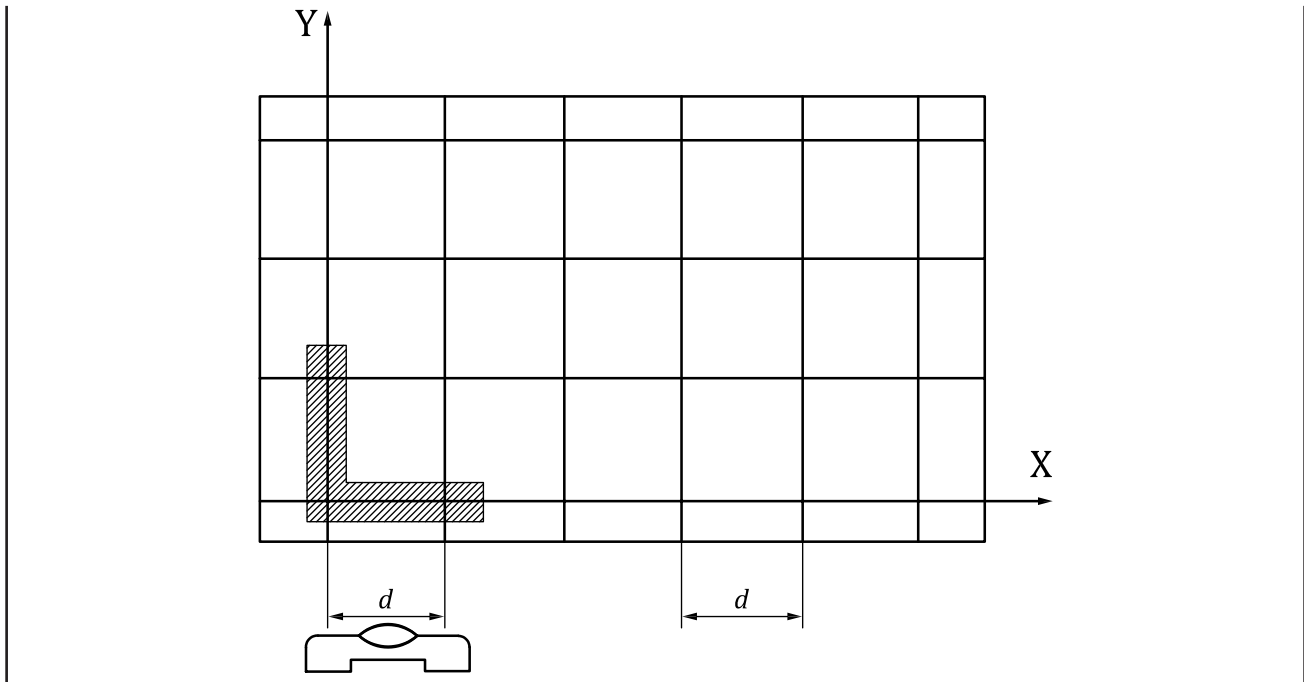

iTeh Standards
(<https://standards.iteh.ai>)
Document Preview

[ISO 6779:2023](#)

<https://standards.iteh.ai/catalog/standards/sist/bc1b2887-8d30-4364-8a82-e39071ac996d/iso-6779-2023>