**Aerospace — Rivets, solid, 100° normal
countersunk head with dome, metallic
material, with or without surface
treatment — Dimensions**

*Aéronautique et espace — Rivets ordinaires, à tête fraisée 100° normale
avec dôme, en matériau métallique, avec ou sans traitement de surface —
Dimensions*

iTeh STANDARD PREVIEW
(standards.iteh.ai)

[ISO 3230:1998](https://standards.iteh.ai/catalog/standards/sist/9a3fb172-d21b-41c7-83da-b3581f8396d9/iso-3230-1998)

[https://standards.iteh.ai/catalog/standards/sist/9a3fb172-d21b-41c7-83da-
b3581f8396d9/iso-3230-1998](https://standards.iteh.ai/catalog/standards/sist/9a3fb172-d21b-41c7-83da-b3581f8396d9/iso-3230-1998)



Foreword

ISO (the International Organization for Standardization) is a worldwide federation of national standards bodies (ISO member bodies). The work of preparing International Standards is normally carried out through ISO technical committees. Each member body interested in a subject for which a technical committee has been established has the right to be represented on that committee. International organizations, governmental and non-governmental, in liaison with ISO, also take part in the work. ISO collaborates closely with the International Electrotechnical Commission (IEC) on all matters of electrotechnical standardization.

Draft International Standards adopted by the technical committees are circulated to the member bodies for voting. Publication as an International Standard requires approval by at least 75 % of the member bodies casting a vote.

International Standard ISO 3230 was prepared by Technical Committee ISO/TC 20, *Aircraft and space vehicles*, Subcommittee SC 4, *Aerospace fastener systems*.

iTeh STANDARD PREVIEW
(standards.iteh.ai)
<https://standards.iteh.ai/catalog/standards/sist/9a3fb172-d21b-41c7-83da-b3581f8396d9/iso-3230-1998>

© ISO 1998

All rights reserved. Unless otherwise specified, no part of this publication may be reproduced or utilized in any form or by any means, electronic or mechanical, including photocopying and microfilm, without permission in writing from the publisher.

International Organization for Standardization
Case postale 56 • CH-1211 Genève 20 • Switzerland
Internet central@iso.ch
X.400 c=ch; a=400net; p=iso; o=isocs; s=central

Printed in Switzerland

Aerospace — Rivets, solid, 100° normal countersunk with dome, metallic material, with or without surface treatment — Dimensions

1 Scope

This International Standard specifies the dimensions of solid rivets, 100° normal countersunk head with dome, in metallic material, with or without surface treatment.

It is intended for the drawing up of aerospace product standards.

2 Normative reference

The following standard contains provisions which, through reference in this text, constitute provisions of this International Standard. At the time of publication, the edition indicated was valid. All standards are subject to revision, and parties to agreements based on this International Standard are encouraged to investigate the possibility of applying the most recent edition of the standard indicated below. Members of IEC and ISO maintain registers of currently valid International Standards.

ISO 286-2:1988, *ISO system of limits and fits — Part 2: Tables of standard tolerance grades and limit deviations for holes and shafts*.

3 Configuration and dimensions

See figure 1 and tables 1 to 3. Dimensions and tolerances are expressed in millimetres. They are applicable after any surface treatment.

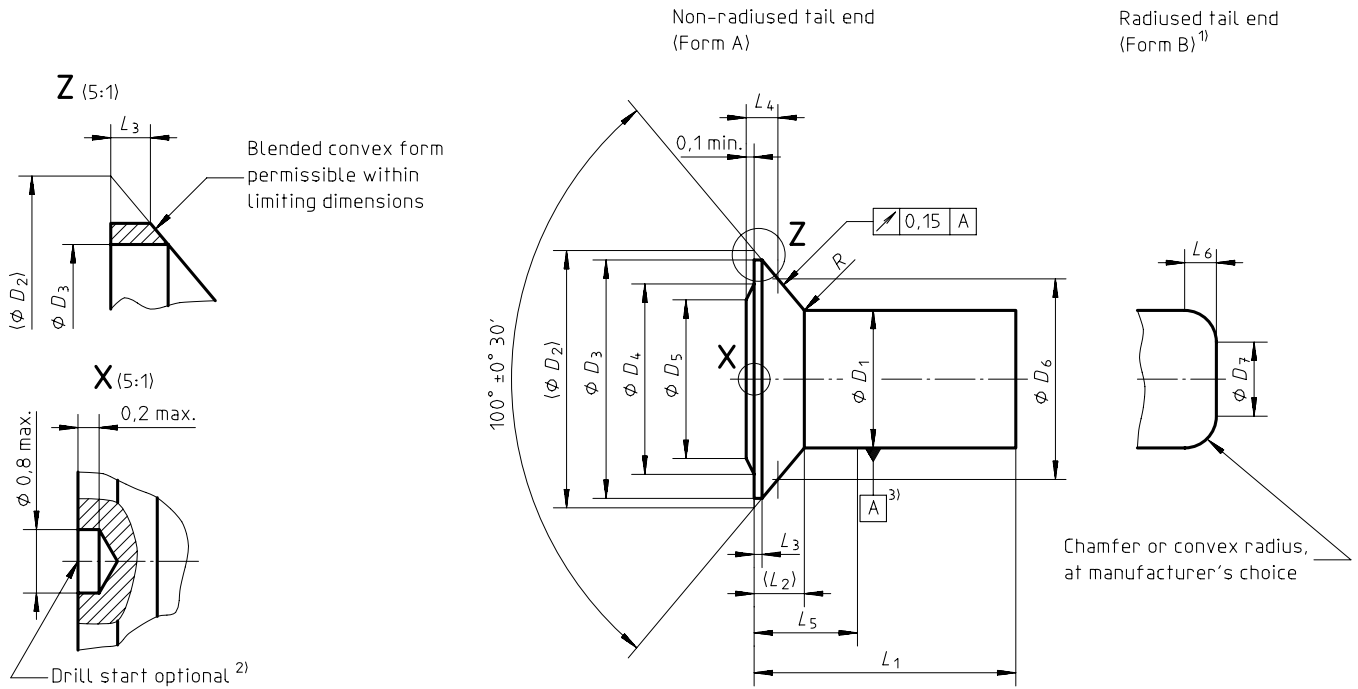

- 1) The length range is limited (see tables 2 and 3).
- 2) Drill start optional, only for corrosion-resistant steels, nickel alloys, commercially pure titanium, titanium alloys.
- 3) Area of this datum shall be included between L_1 and $L_5 + 1$.

HIGH STANDARD PREVIEW
(standards.iteh.ai)

Figure 1

ISO 3230:1998

<https://standards.iteh.ai/catalog/standards/sist/9a3fb172-d21b-41c7-83da-b3581f8396d9/iso-3230-1998>
Table 1 — Dimensions (except length L_1)

code	D_1 ¹⁾	D_2 ³⁾	D_3 min.	D_4		D_5		D_6	D_7		L_2	L_3 min.	L_4 0 -0,08	L_5		L_6		R ± 0,08
	d11 ²⁾			max.	min.	max.	min.		max.	min.				max.	min.	max.	min.	
016	1,6	3	2,7	2,7	2,2	2,2	1,6	2,25	—	—	0,59	0,03	0,41	2	—	—	0,15	
020	2	3,7	3,3	3,3	2,6	2,6	2,0	2,89	—	—	0,72	0,04	0,44	2,2	—	—		
025	2,5	4,65	4,15	4,15	3,30	3,3	2,5	3,86	2,0	1,7	0,91	0,05	0,43	2,4	0,8	0,5		
030	3	5,55	4,95	4,95	4,00	4	3	4,5	2,4	2,1	1,07	0,06	0,54	2,5	0,9	0,6		
035	3,5	6,5	5,8	5,8	4,6	4,6	3,5	5,14	2,80	2,45	1,26	0,07	0,67	2,8	1,05	0,70	0,25	
040	4	7,4	6,6	6,6	5,3	5,3	4,0	5,78	3,2	2,8	1,43	0,08	0,78	3	1,2	0,8		
050	5	9,25	8,25	8,25	6,60	6,6	5,0	7,71	4,0	3,5	1,8	0,1	0,75	3,8	1,5	1,0		
060	6	11,1	9,9	9,9	8,0	8	6	9	4,8	4,2	2,15		0,98	4,1	1,8	1,2		
100	10	18,5	17,3	17,3	13,6	13,6	10,0	15,43	8	7	3,59		1,39	5,5	3	2		

1) Over length ($L_5 - L_2$), D_1 max. may increase by 0,03.
 2) In accordance with ISO 286-2
 3) Maximum condition

Table 2 — Lengths L_1 for rivets in aluminium and aluminium alloys

Diameter code		016	020	025	030	035	040	050	060	080	100								
Length code	$L_1 +0,5$ 0	Shape of tail end ¹⁾																	
		A	A	A	B	A	B	A	B	A	A	B	A	B	A	B			
003	3	X	X																
004	4	X	X	X	X	X	X	X	X										
005	5	X	X	X	X	X	X	X	X										
006	6	X	X	X	X	X	X	X	X	X	X								
007	7	X	X	X	X	X	X	X	X	X	X								
008	8	X	X	X	X	X	X	X	X	X	X	X	X						
009	9	X	X	X	X	X	X	X	X	X	X	X	X						
010	10	X	X	X	X	X	X	X	X	X	X	X	X	X	X				
012	12	X	X	X	X	X	X	X	X	X	X	X	X	X					
013	13	X	X	X	X	X	X	X	X	X	X	X	X	X	X	X	X	X	X
014	14	X	X	X	X	X	X	X	X	X	X	X	X	X	X	X	X	X	X
015	15	X	X	X	X	X	X	X	X	X	X	X	X	X	X	X	X	X	X
016	16	X	X	X	X	X	X	X	X	X	X	X	X	X	X	X	X	X	X
017	17		X	X	X	X	X	X	X	X	X	X	X	X	X	X	X	X	X
018	18		X	X	X	X	X	X	X	X	X	X	X	X	X	X	X	X	X
019	19		X	X		X	X	X	X	X	X	X	X	X	X	X	X	X	X
020	20		X	X		X	X	X	X	X	X	X	X	X	X	X	X	X	X
022	22		X	X		X	X	X	X	X	X	X	X	X	X	X	X	X	X
024	24		X	X		X	X	X	X	X	X	X	X	X	X	X	X	X	X
028	28			X		X		X		X	X	X	X	X	X	X	X	X	X
030	30			X		X		X		X		X	X	X	X	X	X	X	X
032	32			X		X		X		X		X	X	X	X	X	X	X	X
035	35			X		X		X		X		X		X	X	X	X	X	X
040	40					X		X		X		X		X		X		X	
045	45							X		X		X		X		X		X	
050	50									X		X		X		X		X	
055	55											X		X		X		X	
060	60											X		X		X		X	

1) Form A : non-radiused tail end (see figure 1)
Form B : radiused tail end (see figure 1)

Table 3 — Lengths L_1 for rivets in nickel alloys, corrosion-resistant steels, commercially pure titanium and titanium alloys

Diameter code		016	020	025		030		035		040		050		060	
Length code	$L_1 \begin{smallmatrix} +0,5 \\ 0 \end{smallmatrix}$	Shape of tail end ¹⁾													
		A	A	A	B	A	B	A	B	A	B	A	B	A	B
003	3	X	X												
004	4	X	X	X	X	X	X	X							
005	5	X	X	X	X	X	X	X	X						
006	6	X	X	X	X	X	X	X	X	X	X				
007	7	X	X	X	X	X	X	X	X	X	X				
008	8	X	X	X	X	X	X	X	X	X	X	X	X		
009	9	X	X	X	X	X	X	X	X	X	X	X	X		
010	10	X	X	X	X	X	X	X	X	X	X	X	X	X	X
011	11	X	X	X	X	X	X	X	X	X	X	X	X	X	X
012	12	X	X	X	X	X	X	X	X	X	X	X	X	X	
013	13	X	X	X	X	X	X	X	X	X	X	X	X	X	X
014	14	X	X	X	X	X	X	X	X	X	X	X	X	X	X
015	15	X	X	X	X	X	X	X	X	X	X	X	X	X	X
016	16	X	X	X	X	X	X	X	X	X	X	X	X	X	X
017	17		X	X	X	X	X	X	X	X	X	X	X	X	X
018	18		X	X		X	X	X	X	X	X	X	X	X	X
019	19			X		X	X	X	X	X	X	X	X	X	X
020	20			X		X	X	X	X	X	X	X	X	X	X
022	22					X		X		X	X	X	X	X	X
024	24					X		X		X	X	X	X	X	X
026	26							X		X		X	X	X	X
028	28							X		X		X	X	X	X
030	30									X		X		X	X
032	32									X		X		X	X
040	40											X		X	

1) Form A : non-radiused tail end (see figure 1)
 Form B : radiused tail end (see figure 1)

iTeh STANDARD PREVIEW
(standards.iteh.ai)

ISO 3230:1998

<https://standards.iteh.ai/catalog/standards/sist/9a3fb172-d21b-41c7-83da-b3581f8396d9/iso-3230-1998>

iTeh STANDARD PREVIEW
(standards.iteh.ai)

[ISO 3230:1998](https://standards.iteh.ai/catalog/standards/sist/9a3fb172-d21b-41c7-83da-b3581f8396d9/iso-3230-1998)

<https://standards.iteh.ai/catalog/standards/sist/9a3fb172-d21b-41c7-83da-b3581f8396d9/iso-3230-1998>

ICS 49.030.99

Descriptors: aircraft industry, fasteners, rivets, countersunk head rivets, form specifications, dimensions, dimensional tolerances.

Price based on 4 pages
