

**ISO/TC 106/SC 1**

Date: 2022-03-~~21~~25

**ISO/FDIS 3107:2022(E)**

ISO/TC 106/SC 1

Secretariat: AFNOR

**Dentistry — Zinc oxide/eugenol cements and zinc oxide/non-eugenol cements**

*Médecine bucco-dentaire — Ciments dentaires à base d'oxyde de zinc-eugénol et à base d'oxyde de zinc sans eugénol*

**iTeh STANDARD PREVIEW**  
**(standards.iteh.ai)**

[ISO/FDIS 3107](https://standards.iteh.ai/catalog/standards/sist/6a5d4209-dc8c-4e16-95df-d83ead771d82/iso-fdis-3107)

<https://standards.iteh.ai/catalog/standards/sist/6a5d4209-dc8c-4e16-95df-d83ead771d82/iso-fdis-3107>



~~COPYRIGHT PROTECTED DOCUMENT~~

© ISO 2022

All rights reserved. Unless otherwise specified, or required in the context of its implementation, no part of this publication may be reproduced or utilized otherwise in any form or by any means, electronic or mechanical, including photocopying, or posting on the internet or an intranet, without prior written permission. Permission can be requested from either ISO at the address below or ~~ISO's~~ISO's member body in the country of the requester.

ISO Copyright Office

~~Ch. de Blandonnet 8 • CP 401 • CH-1214 Vernier, Geneva, Switzerland~~

~~Tel. Phone: + 41 22 749 01 11~~

~~Email: [copyright@iso.org](mailto:copyright@iso.org) Fax + 41 22 749 09 47~~

~~[copyright@iso.org](mailto:copyright@iso.org)~~

~~[www.iso.org](http://www.iso.org)~~

~~Website: [www.iso.org](http://www.iso.org)~~

~~Published in Switzerland.~~

iTeh STANDARD PREVIEW  
(standards.iteh.ai)

ISO/FDIS 3107

<https://standards.iteh.ai/catalog/standards/sist/6a5d4209-dc8c-4e16-95df-d83ead771d82/iso-fdis-3107>

<b>Contents</b>	<b>Page</b>
Foreword.....	iv
Introduction.....	v
<b>1 Scope .....</b>	<b>1</b>
<b>2 Normative references .....</b>	<b>1</b>
<b>3 Terms and definitions.....</b>	<b>1</b>
<b>4 Classification .....</b>	<b>1</b>
<b>5 Requirements.....</b>	<b>2</b>
<b>5.1 Performance requirements .....</b>	<b>2</b>
<b>5.2 Biocompatibility.....</b>	<b>2</b>
<b>6 Sampling .....</b>	<b>2</b>
<b>7 Test methods.....</b>	<b>2</b>
<b>7.1 Preparation of test specimens .....</b>	<b>2</b>
<b>7.1.1 Ambient conditions.....</b>	<b>2</b>
<b>7.1.2 Procedure for mixing .....</b>	<b>2</b>
<b>7.2 Determination of setting time.....</b>	<b>3</b>
<b>7.2.1 Apparatus.....</b>	<b>3</b>
<b>7.2.2 Procedure .....</b>	<b>3</b>
<b>7.2.3 Treatment of results.....</b>	<b>4</b>
<b>7.3 Determination of compressive strength .....</b>	<b>4</b>
<b>7.3.1 Apparatus .....</b>	<b>4</b>
<b>7.3.2 Preparation of test specimens .....</b>	<b>5</b>
<b>7.3.3 Procedure.....</b>	<b>6</b>
<b>7.3.4 Treatment of results.....</b>	<b>6</b>
<b>7.4 Determination of film thickness .....</b>	<b>6</b>
<b>7.4.1 Apparatus .....</b>	<b>6</b>
<b>7.4.2 Procedure .....</b>	<b>7</b>
<b>7.4.3 Treatment of results.....</b>	<b>7</b>
<b>7.5 Determination of acid-soluble arsenic fraction.....</b>	<b>8</b>
<b>7.5.1 Preparation of test sample.....</b>	<b>8</b>
<b>7.5.2 Procedure.....</b>	<b>9</b>
<b>7.5.3 Compliance.....</b>	<b>9</b>
<b>8 Marking, labelling and packaging.....</b>	<b>9</b>
<b>8.1 Packaging.....</b>	<b>9</b>
<b>8.2 Marking and instructions for use.....</b>	<b>9</b>
<b>Bibliography .....</b>	<b>11</b>

## Foreword

ISO (the International Organization for Standardization) is a worldwide federation of national standards bodies (ISO member bodies). The work of preparing International Standards is normally carried out through ISO technical committees. Each member body interested in a subject for which a technical committee has been established has the right to be represented on that committee. International organizations, governmental and non-governmental, in liaison with ISO, also take part in the work. ISO collaborates closely with the International Electrotechnical Commission (IEC) on all matters of electrotechnical standardization.

The procedures used to develop this document and those intended for its further maintenance are described in the ISO/IEC Directives, Part 1. In particular, the different approval criteria needed for the different types of ISO documents should be noted. This document was drafted in accordance with the editorial rules of the ISO/IEC Directives, Part 2 (see [www.iso.org/directives](http://www.iso.org/directives)).

Attention is drawn to the possibility that some of the elements of this document may be the subject of patent rights. ISO shall not be held responsible for identifying any or all such patent rights. Details of any patent rights identified during the development of the document will be in the Introduction and/or on the ISO list of patent declarations received (see [www.iso.org/patents](http://www.iso.org/patents)).

Any trade name used in this document is information given for the convenience of users and does not constitute an endorsement.

For an explanation of the voluntary nature of standards, the meaning of ISO specific terms and expressions related to conformity assessment, as well as information about ISO's adherence to the World Trade Organization (WTO) principles in the Technical Barriers to Trade (TBT), see [www.iso.org/iso/foreword.html](http://www.iso.org/iso/foreword.html).

This document was prepared by Technical Committee ISO/TC 106, *Dentistry*, Subcommittee SC 1, *Filling and restorative materials*, in collaboration with the European Committee for Standardization (CEN) Technical Committee CEN/TC 55, *Dentistry*, in accordance with the Agreement on technical cooperation between ISO and CEN (Vienna Agreement).

This fifth edition cancels and replaces the fourth edition (ISO 3107:2011), ~~which has been editorially revised to keep the consistency of the "Terms and definitions" defined in ISO 1942. The changes compared to the previous edition are as follows: of which it constitutes a minor revision.~~

— replace ~~"zinc oxide/eugenol cement"~~ with ~~"zinc oxide-eugenol cement"~~,

— replace ~~"non-eugenol cement"~~ with ~~"non-eugenol zinc oxide cement"~~ and,

— replace ~~"aromatic oils"~~ with ~~"oil(s) other than eugenol"~~.

Any feedback or questions on this document should be directed to the user's national standards body. A complete listing of these bodies can be found at [www.iso.org/members.html](http://www.iso.org/members.html).

## Introduction

Specific qualitative and quantitative requirements for freedom from biological hazard are not included in this document, but it is intended that in assessing possible biological or toxicological hazards, reference be made to ISO 10993-1 and ISO 7405.

iTeh STANDARD PREVIEW  
(standards.iteh.ai)

[ISO/FDIS 3107](https://standards.iteh.ai/catalog/standards/sist/6a5d4209-dc8c-4e16-95df-d83ead771d82/iso-fdis-3107)

<https://standards.iteh.ai/catalog/standards/sist/6a5d4209-dc8c-4e16-95df-d83ead771d82/iso-fdis-3107>



# Dentistry — Zinc oxide/eugenol cements and zinc oxide/non-eugenol cements

## 1 Scope

This document specifies requirements for zinc oxide-eugenol cements suitable for use in restorative dentistry for temporary cementation, for bases and as temporary restorations.

This document also specifies requirements for non-eugenol zinc oxide cements containing zinc oxide and oil(s) other than eugenol for temporary cementation.

## 2 Normative references

The following documents are referred to in the text in such a way that some or all of their content constitutes requirements of this document. For dated references, only the edition cited applies. For undated references, the latest edition of the referenced document (including any amendments) applies.

ISO 1942, *Dentistry — Vocabulary*

ISO 2590, *General method for the determination of arsenic — Silver diethyldithiocarbamate photometric method*

ISO 3696:1987, *Water for analytical laboratory use — Specification and test methods*

[https://standards.iteh.ai/catalog/standards/sist/6a5d4209-dc8c-4e16-95df-d83ead771d82/iso-](https://standards.iteh.ai/catalog/standards/sist/6a5d4209-dc8c-4e16-95df-d83ead771d82/iso-8601-1)  
ISO 8601-1, *Date and time — Representations for information interchange — Part 1: Basic rules*

## 3 Terms and definitions

For the purposes of this document, the terms and definitions given in ISO 1942 apply.

ISO and IEC maintain **terminological terminology** databases for use in standardization at the following addresses:

— ISO Online browsing platform: available at <https://www.iso.org/obp>

— IEC Electropedia: available at <https://www.electropedia.org/>

## 4 Classification

For the purposes of this document, the following classification for cements is used, based on their intended use:

- a) Type I: for temporary cementation;
- b) Type II: for bases and temporary restorations.

## 5 Requirements

### 5.1 Performance requirements

When tested in accordance with the appropriate test methods specified in Clause 7, Type I and Type II cements shall comply with the performance requirements specified in Table 1.

**Table 1 — Requirements**

Type	Setting time at 37 °C		Compressive strength at 24 h		Film thickness	Acid-soluble arsenic mass fraction
	min	max	min	max	µm	mg/kg <sup>a</sup>
	<del>min</del> - <del>mini</del> <del>mum</del>	<del>max</del> - <del>maxi</del> <del>mum</del>	<del>min</del> - <del>minim</del> <del>um</del>	<del>max</del> - <del>maxi</del> <del>mum</del>	<del>max</del> - <del>maximum</del>	<del>max</del> - <del>maximum</del>
Type I	1,5	10		35	25	2
Type II	1,5	10	5		N/A	2

N/A: not applicable

<sup>a</sup> mg/kg is the equivalent of ppm; ppm is a deprecated unit.

### 5.2 Biocompatibility

For guidance on biocompatibility, see ISO 10993-1 and ISO 7405.

## 6 Sampling

The test sample shall consist of packages prepared for retail sale from the same batch containing enough material to carry out the specified tasks plus an allowance for repeats. 50 g should be sufficient.

## 7 Test methods

### 7.1 Preparation of test specimens

Prepare the test material in accordance with the manufacturer's instructions (see 8.2).

#### 7.1.1 Ambient conditions

Prepare and test all specimens at  $(23 \pm 2)$  °C and a relative humidity of  $(50 \pm 5)$  %. Before the start of mixing, condition the test samples and apparatus in these conditions for at least 1 h.

#### 7.1.2 Procedure for mixing

Mix sufficient cement to ensure that the preparation of each specimen is completed from one mix. Prepare a fresh mix for each specimen.

### 7.2 Determination of setting time

#### 7.2.1 Apparatus

**7.2.1.1 Cabinet**, capable of being maintained at a temperature of  $(37 \pm 1)$  °C and a relative humidity of  $(95 \pm 5)$  %.

#### 7.2.1.2 Indenter needle



**7.2.1.2.1** For Type I materials, an indenter needle of mass  $(100 \pm 0,5)$  g with a tip which is cylindrical for a distance of approximately 5 mm and has a flat end of diameter  $(2,0 \pm 0,1)$  mm.

**7.2.1.2.2** For Type II materials, a similar indenter needle of mass  $(400 \pm 5)$  g with a tip which is cylindrical for a distance of approximately 5 mm, and which has a flat end of diameter  $(1,0 \pm 0,1)$  mm.

**7.2.1.3 Mould**, made of non-corrodible metal, consisting of a rectangular plate with a circular hole conforming to the dimensions given in Figure 1.

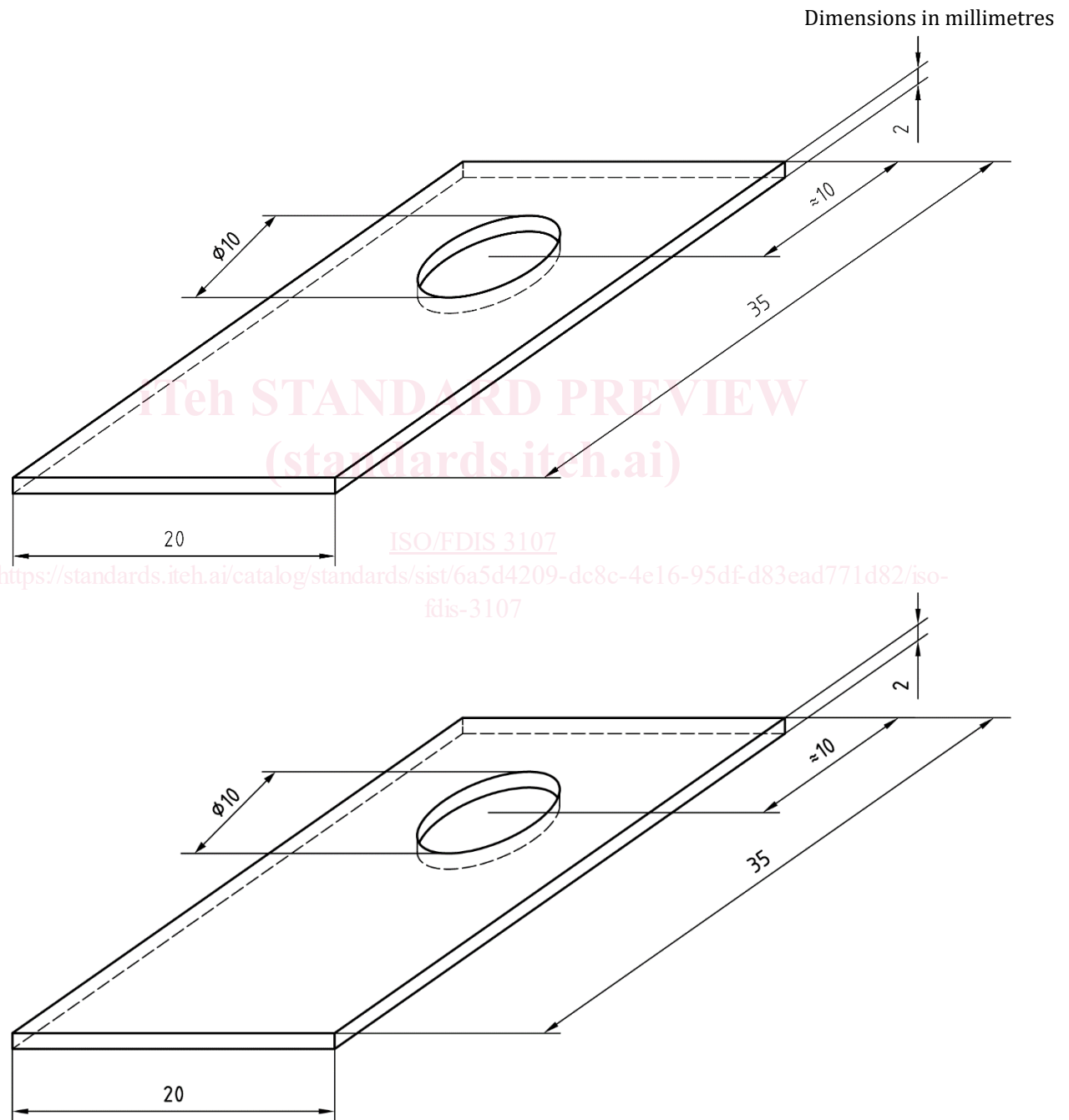

**Figure 1** — Mould for use in determination of setting time

**7.2.1.4 Metal block**, of minimum dimensions 8 mm  $\times$  20 mm  $\times$  10 mm.

7.2.1.5 **Flat glass plate**, approximately 1 mm thick (for example, e.g. a microscopic slide).

7.2.2 **Procedure**

Condition the metal block (7.2.1.4) and indenter needle (7.2.1.2) in the cabinet (7.2.1.1) at  $(37 \pm 1) ^\circ\text{C}$ .

Place the metal mould (7.2.1.3), conditioned at  $(23 \pm 1) ^\circ\text{C}$ , on the flat glass plate (7.2.1.5) and fill to a level surface with the cement.

After  $(60 \pm 10)$  s from the start of mixing for all cements, place the specimen, mould and glass plate on to the metal block.

~~30 s~~ **Thirty seconds** before the setting time given by the manufacturer, carefully lower the indenter needle vertically on to the surface of the cement. Make indentations at 15 s intervals with no superimposition of indentations until the setting time has been reached. Maintain the needle tip in a clean condition between indentations.

Record the setting time, to the nearest 15 s, as the period of time which elapses from the start of mixing to the time when the needle fails to penetrate completely the 2 mm depth of cement.

7.2.3 **Treatment of results**

The result shall either be one of the limit values or lie between the limits given in Table 1.

7.3 **Determination of compressive strength**

7.3.1 **Apparatus**

7.3.1.1 **Split moulds and plates**, for example as shown in Figure 2, suitable for the preparation of a cylindrical specimen with a height of 6 mm and a diameter of 4 mm, and made of a material that is neither attacked nor corroded by the cement, such as stainless steel.

