



Designation: ~~C1521 – 09~~<sup>e1</sup> C1521 – 13

# Standard Practice for Evaluating Adhesion of Installed Weatherproofing Sealant Joints<sup>1</sup>

This standard is issued under the fixed designation C1521; the number immediately following the designation indicates the year of original adoption or, in the case of revision, the year of last revision. A number in parentheses indicates the year of last reapproval. A superscript epsilon ( $\epsilon$ ) indicates an editorial change since the last revision or reapproval.

---

<sup>e1</sup> NOTE—Editorial changes were made in Section 7 in December 2009.

---

## 1. Scope

1.1 This practice describes destructive and nondestructive procedures.

1.2 The destructive procedure stresses the sealant in such a way as to cause either cohesive or adhesive failure of the sealant or cohesive failure of the substrate where deficient substrate conditions exist. The objective is to characterize the adhesive/cohesive performance of the sealant on the specific substrate by applying whatever strain is necessary to effect failure of the sealant bead. It is possible that the strain applied to the sealant bead may result in the failure of a deficient substrate before effecting a failure in the sealant.

NOTE 1—The destructive procedure requires immediate repair of the sealant bead. Appropriate materials and equipment should be available for this purpose.

NOTE 2—Sealant formulations may fail in cohesion or adhesion when properly installed, and tested by this method. The sealant manufacturer should be consulted to determine the appropriate guidelines for using this method.

1.3 The nondestructive procedure places strain on the sealant and a stress on the adhesive bond. Though termed nondestructive, this procedure may result in an adhesive failure of a deficient sealant bead, but should not cause a cohesive failure in the sealant. The results of this procedure should be either adhesive failure or no failure.

NOTE 3—The nondestructive procedure may require immediate repair of the sealant bead, if failure is experienced. Appropriate materials and equipment should be available for this purpose.

1.4 The non-destructive procedure can be used for continuous inspection of 100 % of the joint(s) or for any areas where deficient conditions, which are inconsistent with the practices of Guide C1193, are suspected.

1.5 The committee with jurisdiction over this practice is not aware of any comparable practices published by other organizations or committees.

1.6 The values stated in inch-pound units are to be regarded as standard. The values given in parentheses are mathematical conversions to SI units that are provided for information only and are not considered standard.

1.7 *This standard does not purport to address all of the safety concerns, if any, associated with its use. It is the responsibility of the user of this standard to establish appropriate safety and health practices and determine the applicability of regulatory limitations prior to use.*

## 2. Referenced Documents

2.1 *ASTM Standards:*<sup>2</sup>

[C717 Terminology of Building Seals and Sealants](#)

[C794 Test Method for Adhesion-in-Peel of Elastomeric Joint Sealants](#)

[C1193 Guide for Use of Joint Sealants](#)

## 3. Terminology

3.1 *Definitions*—For definitions of terms used in this recommended procedure, see Terminology C717.

3.2 *Definitions of Terms Specific to This Standard:*

---

<sup>1</sup> This practice is under the jurisdiction of ASTM Committee C24 on Building Seals and Sealants and is the direct responsibility of Subcommittee C24.30 on Adhesion. Current edition approved June 1, 2009; May 1, 2013. Published July 2009; May 2013. Originally approved in 2002. Last previous edition approved in 2008 as C1521 – 08a; C1521 – 09<sup>e1</sup>. DOI: 10.1520/C1521-09; 10.1520/C1521-13.

<sup>2</sup> For referenced ASTM standards, visit the ASTM website, www.astm.org, or contact ASTM Customer Service at service@astm.org. For *Annual Book of ASTM Standards* volume information, refer to the standard's Document Summary page on the ASTM website.

3.2.1 *flap, n*—the term “flap” as used in this specification refers to a portion of an installed sealant bead that has been purposely cut along one substrate bond line and across the bead at two locations resulting in a portion of bead adhered along one substrate bond line.

3.2.2 *tail, n*—the term “tail” as used in this specification refers to a portion of an installed sealant bead that has been purposely cut along both substrate bond lines and across the bead at one location resulting in a portion of bead unadhered to the substrates but adhered to the remainder of the sealant bead.

#### 4. Significance and Use

4.1 Many parameters contribute to the overall performance of a sealant application. Some of the most significant parameters are sealant bead size and configuration, joint movement, quality of workmanship, the quality of the adhesive bond, and the quality of the sealant material.

4.2 A sealant usually fails to perform as a weatherseal when it experiences cohesive or adhesive failure.

4.3 If a sealant bead fails, an evaluation of the total joint movement may be needed to determine if the joint sealant was strained beyond design or if the sealant failed within design parameters.

4.4 If a sealant bead fails adhesively, there is no straightforward procedure for determining the cause. The adhesive failure may be due to workmanship, the specific surface preparation used, the specific sealant used, poor “installed” joint design, poor bond chemistry and other causes.

4.5 Because of the complex nature of the performance of a sealant bead, an understanding of the quality of the adhesive bond is instrumental in any evaluation of sealant performance. It is critical that the test procedures used truly evaluate the quality of the adhesive bond and do not simply take advantage of the tear resistance of the sealant.

4.6 This method does not evaluate the performance of a sealant joint as a weatherseal. It only evaluates the characteristics of the adhesive bond relative to the cohesive strength of the sealant in a particular installation. Since any failures that result from use of this test method are intentionally induced, they do not necessarily mean that the sealant joint will not perform as a weatherseal.

4.7 The results of these methods are most useful in identifying sealant joints with poor adhesion. The continuous inspection procedure is also useful in the identification of places of poor joint configuration. Obvious cohesive failures are also identified. The results of these methods can be used to assess the likely performance of the sealant joint and to compare performance against other sealant joints.

4.8 The nondestructive methods are most effective while the sealant is in a state of extension due to mild or low temperatures. They are least effective during high temperature when the sealant is in a compressed condition.

#### 5. Testing Equipment

5.1 *Field Equipment*—The following equipment is required to perform this practice: rule with  $\frac{1}{32}$  in. divisions (mm), probing tool, razor knife, knife or other cutting instrument with a pointed 2 in. (50 mm) minimum length blade, sealable sample bags, repair sealant compatible with existing sealant, tools for installing sealant, butyl tape, water.

5.2 *Field Equipment, Nondestructive Continuous Method*—A wheel roller such as a screen roller or a backer rod insertion roller or a pressure controlled roller.

5.3 Provide materials for recording data. These may include masking tape, marking pen, note books, shop or architectural drawings, a camera or video recorder, or both.

#### 6. Summary of Methods

6.1 *Nondestructive Spot Method*—This method makes use of a blunt dowel shaped tool to impart pressure against the surface of the sealant bead. Firm pressure is applied to the surface of the sealant in the center of the bead and near the bond line. This method evaluates a discrete area of the sealant bead and is repeated numerous times to provide an evaluation of a given length of sealant joint.

6.2 *Nondestructive Continuous Method*—This method makes use of a wheel to impart pressure against the surface of the sealant bead. The wheel is rolled continuously along the center of the sealant bead to provide 100 % inspection of a given length of sealant joint.

6.3 *All Methods*—Data is collected continuously for all methods. Precise description of location and type of all anomalies is recorded by a method appropriate for the given evaluation. See Appendix X1.

6.4 *Destructive Method*—This method is performed by cutting through the sealant bead to provide either a “tail” or a “flap” of sealant that can be pulled by hand, to stress the bond line of the sealant. The width and location of the sealant bead will determine how and to what degree the hand pull method can be performed. This method uses described techniques to cause an adhesive failure from the substrate.

6.4.1 *Water Immersion*—This method makes use of a vessel filled with water to expose a sealant bead to water before performing the procedures described in 7.1-7.4. This method can also be performed in the event that project specific substrates are not able to be evaluated in the laboratory for surface preparation recommendations based on testing in accordance with adhesion methods such as Test Method C794. It is advisable to perform a field adhesion evaluation both dry and wet.

NOTE 4—Narrow joints (less than 5/16 in. or 8 mm wide) do not lend themselves to destructive field adhesion tests. Usually, some kind of “tail” can be provided to perform an adhesion pull. However, these tests tend to evaluate the cohesive property of the sealant more than the adhesive property.

NOTE 5—Joints that are less than 5/8 in. or 16 mm wide or that are more than 1/2 in. (13 mm) deep do not lend themselves to a “flap” style adhesion pull. The “tail” style adhesion pull should be performed on these joints.

**7. Procedures**

*7.1 Nondestructive Procedure:*

7.1.1 Select a probing tool that is at least 1/8 in. (3 mm) narrower than the width of the sealant joint to be evaluated. Fig. 1 provides example dimensions for a probing tool.

NOTE 6—The probing tool should be blunt without sharp edges and shaped in such a way that it will not puncture the sealant bead.

7.1.2 *Technique 1*—Using the probing tool, depress the center of the sealant bead to create an elongation strain on the sealant joint. Record the depth of the depression as a percentage of the width of the bead. A common percentage used to create reasonable strain and reveal poor adhesion is 50 %. The appropriate percentage varies with each sealant joint and is approximately proportional to the expected joint movement. The percentage can be correlated with destructive procedure test results.

7.1.3 *Technique 2*—Locating the probing tool adjacent to the sealant/substrate bond line, depress the sealant bead to the extent that (visually) it appears the sealant is about to fail cohesively. The sealant bead should be depressed in such a way that the probing tool does not contact or scrape against the substrate, nor slide toward the center of the joint. This technique will effect a peel-type strain on the sealant joint. This technique will produce shear forces close to the bond line and therefore the results should be prudently interpreted.

*7.2 Nondestructive Continuous Inspection Procedure:*

7.2.1 Place masking tape on the exposed surface of the substrate adjacent to the sealant to be inspected. Using a roller of such thickness as to be equal to or less than half of the width of the joint, apply pressure to the sealant through the roller to develop a depression in the sealant joint that represents approximately 50 % deflection of the sealant. Advance the roller along the centerline of the length of the joint, using uniform pressure. Observe the condition of the sealant for conditions, such as deflection of the sealant that is greater than or less than expected, adhesive failure, cohesive failure or mechanical damage to the sealant, and mark the location of these conditions on the masking tape. It is helpful to use characteristic marks such as “A” for adhesion loss, “H” where the sealant appears hard, “S” where the sealant appears soft, “C” where a cohesive failure exists, for example, when marking the masking tape. Where extended length of adhesive failure occurs, the masking tape can be marked to indicate the ends of the adhesive failures. The tape can also contain markings that identify the location and side of the joint at which it is located. Upon completion of depressing the sealant with the roller, documentation of the locations and types of conditions can be performed.

7.2.2 *Determining the Causes of the Anomalies*—Each anomaly can be inspected for obvious causes. However, it is generally helpful to remove a portion of the sealant and backer material for inspection. Sometimes, a more thorough examination of the anomaly location will be required. The destructive procedure described in 7.3 can be used.

*7.3 Destructive Procedure:*

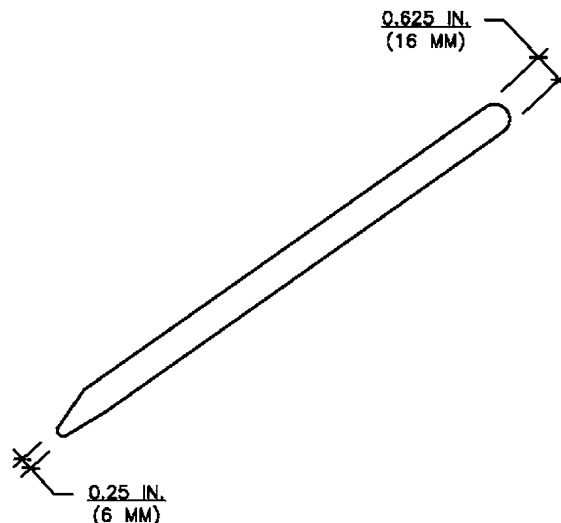

FIG. 1 Probing Tool

7.3.1 The “Tail” Procedure consists of cutting through the sealant, 6 in. (150 mm) along the bond line at both substrates. Cut across the sealant bead to release one end of the “tail” that is formed (see Fig. 2). Insure that the sealant is cut at the substrate and that the sealant bead is free of nicks or jagged edges.

7.3.2 Method A:

7.3.2.1 Mark the cut portion of the sealant 1 in. (25 mm) from the adhesive bond.

7.3.2.2 Grasp the sealant “tail” at the mark 1 in. (25 mm) from the adhesive bond.

7.3.2.3 Pull tail at an angle of 90° to the substrate to effectively extend the 1-in. mark to two times the stated movement capability of the sealant.

7.3.2.4 Record the type of failure that occurred and the distance of the mark from the adhesive bond when failure occurred, or the distance recommended by manufacturer without causing failure.

7.3.3 Method B:

7.3.3.1 Mark the cut portion of the sealant 1 in. (25 mm) from the adhesive bond.

7.3.3.2 Grasp the sealant tail at the mark 1 in. (25 mm) from the adhesive bond.

7.3.3.3 Various tests can be performed pulling the tail slowly at an angle of 30, 90 or 150° to the substrate, keeping the tail in line with the sealant bead as nearly as possible. Monitor the extension to determine the elongation resulting in failure.

NOTE 7—Techniques using the “tail procedure” that allow evaluations of sealant adhesion to one substrate at a time are acceptable.

7.3.3.4 If the sealant begins to tear cohesively, stop pulling and readjust the grasp on the tail and begin pulling again. Pull on the tail in whatever direction or manner that best avoids cohesive tearing and encourages adhesive failure.

7.3.3.5 Repeat procedure as necessary to evaluate adhesion to both substrates forming the joint.

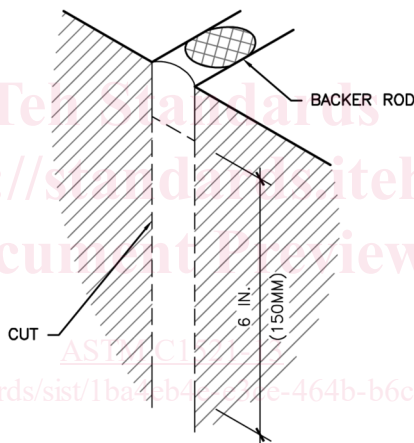

6 IN. (150 MM) CUT THROUGH SEALANT AT BOND LINE OF BOTH SUBSTRATES AND ACROSS ONE END TO CREATE TAIL

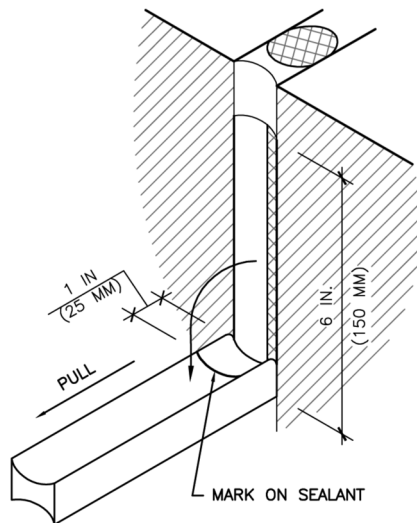

MARK CUT PORTION OF SEALANT 1 IN. (25 MM) FROM ADHESIVE BOND. PULL TAIL.

FIG. 2 Tail Procedure