



**International
Standard**

ISO 13672

**Fasteners — Parallel grooved pins
— Half-length diamond grooves**

*Fixations — Goupilles cannelées constantes — Cannelures
diamant sur la moitié de la longueur*

**First edition
2025-02**

iTeh Standards
(<https://standards.iteh.ai>)
Document Preview

[ISO 13672:2025](https://standards.iteh.ai/catalog/standards/iso/691645e1-1729-409e-8303-f7169d933cda/iso-13672-2025)

<https://standards.iteh.ai/catalog/standards/iso/691645e1-1729-409e-8303-f7169d933cda/iso-13672-2025>

iTeh Standards
(<https://standards.iteh.ai>)
Document Preview

[ISO 13672:2025](https://standards.iteh.ai/catalog/standards/iso/691645e1-1729-409e-8303-f7169d933cda/iso-13672-2025)

<https://standards.iteh.ai/catalog/standards/iso/691645e1-1729-409e-8303-f7169d933cda/iso-13672-2025>



COPYRIGHT PROTECTED DOCUMENT

© ISO 2025

All rights reserved. Unless otherwise specified, or required in the context of its implementation, no part of this publication may be reproduced or utilized otherwise in any form or by any means, electronic or mechanical, including photocopying, or posting on the internet or an intranet, without prior written permission. Permission can be requested from either ISO at the address below or ISO's member body in the country of the requester.

ISO copyright office
CP 401 • Ch. de Blandonnet 8
CH-1214 Vernier, Geneva
Phone: +41 22 749 01 11
Email: copyright@iso.org
Website: www.iso.org

Published in Switzerland

Contents

Page

Foreword.....	iv
1 Scope.....	1
2 Normative references.....	1
3 Terms and definitions.....	1
4 Principles of grooved pins and assembly.....	1
5 Dimensions.....	2
6 Requirements and reference International Standards.....	6
7 Labelling on package.....	6
8 Designation.....	7
Bibliography.....	8

iTeh Standards
(<https://standards.iteh.ai>)
Document Preview

[ISO 13672:2025](https://standards.iteh.ai/catalog/standards/iso/691645e1-1729-409e-8303-f7169d933cda/iso-13672-2025)

<https://standards.iteh.ai/catalog/standards/iso/691645e1-1729-409e-8303-f7169d933cda/iso-13672-2025>

Foreword

ISO (the International Organization for Standardization) is a worldwide federation of national standards bodies (ISO member bodies). The work of preparing International Standards is normally carried out through ISO technical committees. Each member body interested in a subject for which a technical committee has been established has the right to be represented on that committee. International organizations, governmental and non-governmental, in liaison with ISO, also take part in the work. ISO collaborates closely with the International Electrotechnical Commission (IEC) on all matters of electrotechnical standardization.

The procedures used to develop this document and those intended for its further maintenance are described in the ISO/IEC Directives, Part 1. In particular, the different approval criteria needed for the different types of ISO document should be noted. This document was drafted in accordance with the editorial rules of the ISO/IEC Directives, Part 2 (see www.iso.org/directives).

ISO draws attention to the possibility that the implementation of this document may involve the use of (a) patent(s). ISO takes no position concerning the evidence, validity or applicability of any claimed patent rights in respect thereof. As of the date of publication of this document, ISO had not received notice of (a) patent(s) which may be required to implement this document. However, implementers are cautioned that this may not represent the latest information, which may be obtained from the patent database available at www.iso.org/patents. ISO shall not be held responsible for identifying any or all such patent rights.

Any trade name used in this document is information given for the convenience of users and does not constitute an endorsement.

For an explanation of the voluntary nature of standards, the meaning of ISO specific terms and expressions related to conformity assessment, as well as information about ISO's adherence to the World Trade Organization (WTO) principles in the Technical Barriers to Trade (TBT), see www.iso.org/iso/foreword.html.

This document was prepared by Technical Committee ISO/TC 2, *Fasteners*, in collaboration with the European Committee for Standardization (CEN) Technical Committee CEN/TC 185 *Fasteners*, in accordance with the Agreement on technical cooperation between ISO and CEN (Vienna Agreement).

Any feedback or questions on this document should be directed to the user's national standards body. A complete listing of these bodies can be found at www.iso.org/members.html.

[ISO 13672:2025](https://standards.iteh.ai/catalog/standards/iso/691645e1-1729-409e-8303-f7169d933cda/iso-13672-2025)

<https://standards.iteh.ai/catalog/standards/iso/691645e1-1729-409e-8303-f7169d933cda/iso-13672-2025>

Fasteners — Parallel grooved pins — Half-length diamond grooves

1 Scope

This document specifies the characteristics of parallel grooved pins with half-length diamond grooves (with closed ends), in steel and stainless steel, and with nominal diameters 1 mm to 25 mm.

These grooved pins are designed to fulfil the main following functions:

- positioning or guiding, and
- relative rotation of the assembled parts,

with a more significant insertion force (due to its shape) and a high level of pull-out resistance (due to the elastic fit behaviour of the pin).

The general requirements (including functional principles for grooved pins and assembly) are specified in ISO 13669.

2 Normative references

The following documents are referred to in the text in such a way that some or all of their content constitutes requirements of this document. For dated references, only the edition cited applies. For undated references, the latest edition of the referenced document (including any amendments) applies.

ISO 1891-4, *Fasteners — Vocabulary — Part 4: Control, inspection, delivery, acceptance and quality*

ISO 3269, *Fasteners — Acceptance inspection* [ISO 13672:2025](https://standards.iteh.ai/catalog/standards/iso/691645e1-1729-409e-8303-f7169d933cda/iso-13672-2025)

ISO 3506-6, *Fasteners — Mechanical properties of corrosion-resistant stainless steel fasteners — Part 6: General rules for the selection of stainless steels and nickel alloys for fasteners*

ISO 4042, *Fasteners — Electroplated coating systems*

ISO 9717, *Metallic and other inorganic coatings — Phosphate conversion coating of metals*

ISO 10683, *Fasteners — Non-electrolytically applied zinc flake coating systems*

ISO 13669, *Fasteners — Grooved pins — General requirements*

3 Terms and definitions

For the purposes of this document, the terms and definitions given in ISO 13669 apply.

ISO and IEC maintain terminology databases for use in standardization at the following addresses:

- ISO Online browsing platform: available at <https://www.iso.org/obp>
- IEC Electropedia: available at <https://www.electropedia.org/>

4 Principles of grooved pins and assembly

The principles of grooved pins and assembly specified in ISO 13669 shall apply.

5 Dimensions

Dimensions shall be in accordance with [Figure 1](#) and with [Tables 1](#) and [2](#). The control of the expanded diameter d_2 and pin straightness t shall be as specified in ISO 13669.

For coated pins, dimensions and tolerances shall apply prior to coating.

Unless otherwise agreed at the time of the order, the pins are manufactured with rounded ends.

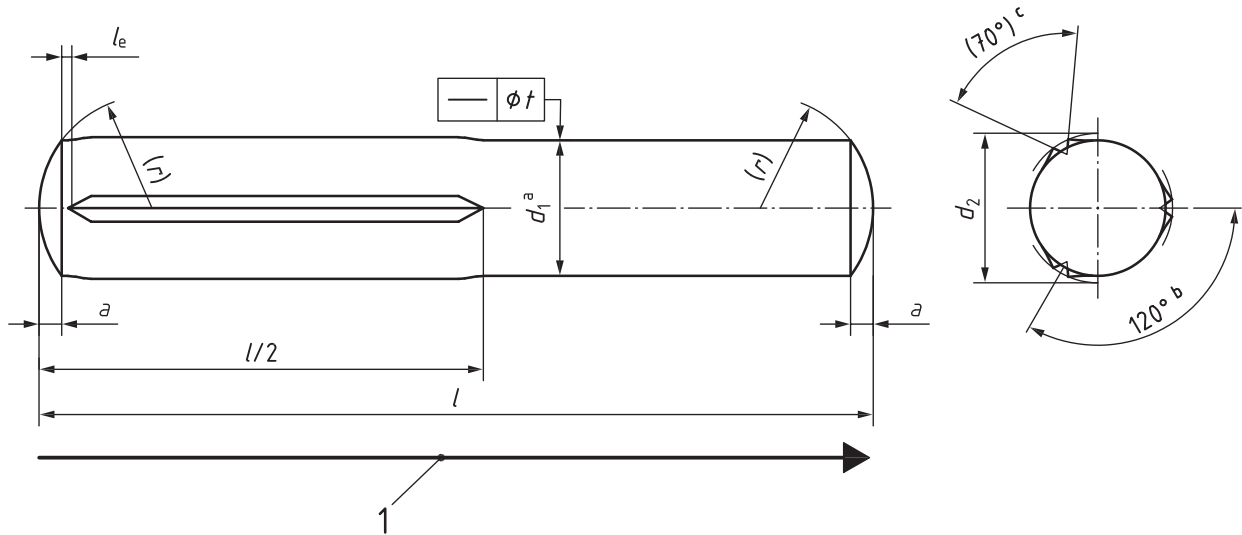

a) With pin rounded ends (RN)

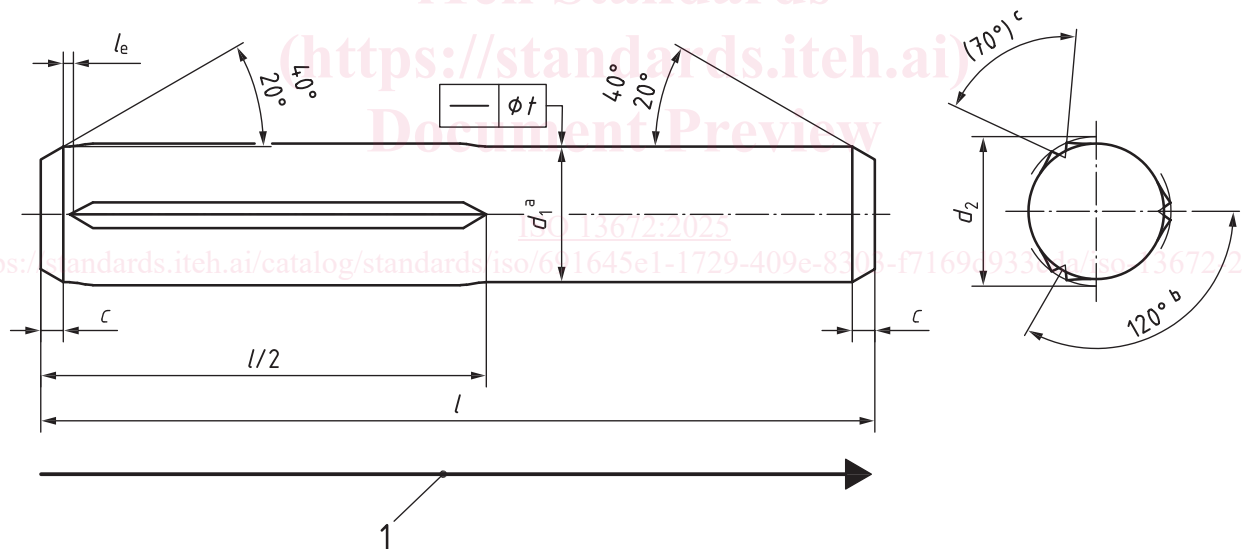

b) With pin chamfered ends (CH)

Key

- 1 insertion side
- a The pin diameter d_1 is only applicable in areas where grooves are not present.
- b The angle of 120° between two grooves applies with a tolerance of $\pm 20^\circ$ (for the three grooves).
- c The groove angle of 70° (for the three grooves) is a reference dimension, see ISO 13669.

Figure 1 — Grooved pin with half-length diamond grooves