

AMENDMENT

IEC/IEEE
80005-
1:2019
FDAM 2

Second edition
2019-03

AMENDMENT 2

ISO/TC 8/SC 3

Secretariat: ANSI

Voting begins on:
2023-01-16

Voting terminates on:
2023-03-13

Utility connections in port —

Part 1: High voltage shore connection (HVSC) systems — General requirements

AMENDMENT 2

Alimentation des navires à quai —

Partie 1: Systèmes de connexion à quai à haute tension — Exigences générales

AMENDEMENT 2

[IEC/IEEE 80005-1:2019/FDAmd 2](https://standards.iteh.ai/catalog/standards/sist/55215766-f877-4158-a19a-bb87eade22ff/iec-ieee-80005-1-2019/fdamd-2)

<https://standards.iteh.ai/catalog/standards/sist/55215766-f877-4158-a19a-bb87eade22ff/iec-ieee-80005-1-2019-fdamd-2>

RECIPIENTS OF THIS DRAFT ARE INVITED TO SUBMIT, WITH THEIR COMMENTS, NOTIFICATION OF ANY RELEVANT PATENT RIGHTS OF WHICH THEY ARE AWARE AND TO PROVIDE SUPPORTING DOCUMENTATION.

IN ADDITION TO THEIR EVALUATION AS BEING ACCEPTABLE FOR INDUSTRIAL, TECHNOLOGICAL, COMMERCIAL AND USER PURPOSES, DRAFT INTERNATIONAL STANDARDS MAY ON OCCASION HAVE TO BE CONSIDERED IN THE LIGHT OF THEIR POTENTIAL TO BECOME STANDARDS TO WHICH REFERENCE MAY BE MADE IN NATIONAL REGULATIONS.



Reference number
IEC/IEEE 80005-1:2019/FDAM 2:2023(E)

© ISO 2023

iTeh STANDARD PREVIEW (standards.iteh.ai)

[IEC/IEEE 80005-1:2019/FDAmd 2](https://standards.iteh.ai/catalog/standards/sist/55215766-f877-4158-a19a-bb87eade22ff/iec-ieee-80005-1-2019-fdamd-2)

<https://standards.iteh.ai/catalog/standards/sist/55215766-f877-4158-a19a-bb87eade22ff/iec-ieee-80005-1-2019-fdamd-2>



COPYRIGHT PROTECTED DOCUMENT

© ISO 2023

All rights reserved. Unless otherwise specified, or required in the context of its implementation, no part of this publication may be reproduced or utilized otherwise in any form or by any means, electronic or mechanical, including photocopying, or posting on the internet or an intranet, without prior written permission. Permission can be requested from either ISO at the address below or ISO's member body in the country of the requester.

ISO copyright office
CP 401 • Ch. de Blandonnet 8
CH-1214 Vernier, Geneva
Phone: +41 22 749 01 11
Email: copyright@iso.org
Website: www.iso.org

Published in Switzerland

rights, and the risk of infringement of such rights, is entirely their own responsibility. Further information may be obtained from ISO or the IEEE Standards Association.

This amendment has been prepared by IEC technical committee 18: Electrical installations of ships and of mobile and fixed offshore units, in cooperation with

- IEC subcommittee 23H: Plugs, socket-outlets and couplers for industrial and similar applications, and for electric vehicles, of IEC technical committee 23: Electrical accessories,
- ISO subcommittee 3: Piping and machinery, of ISO technical committee 8: Ships and marine technology, and
- IEEE IAS Petroleum and chemical industry committee.

This document is published as a triple logo (IEC, ISO and IEEE) standard.

The text of this amendment is based on the following documents:

Draft	Report on voting
18/XX/FDIS	18/XX/RVD

Full information on the voting for the approval of this amendment can be found in the report on voting indicated in the above table. In ISO, the amendment has been approved by XXX P members out of YYY having cast a vote.

The language used for the development of this Amendment is English.

This document was drafted in accordance with ISO/IEC Directives, Part 2, and developed in accordance with ISO/IEC Directives, Part 1 and ISO/IEC Directives, IEC Supplement, available at www.iec.ch/members_experts/refdocs. The main document types developed by IEC are described in greater detail at www.iec.ch/standardsdev/publications.

<https://standards.iteh.ai/catalog/standards/sist/55215766-f877-4158-a19a-bb87eade22ff/iec->
The committee has decided that the contents of this amendment and the base publication will remain unchanged until the stability date indicated on the IEC website under "http://webstore.iec.ch" in the data related to the specific publication. At this date, the publication will be

- reconfirmed,
- withdrawn,
- replaced by a revised edition, or
- amended.

4 General requirements

Add, after the existing 4.9, the following new subclause:

4.10 Ship specific annexes

Annex B to Annex G are ship specific annexes that include additional requirements to safety and compatibility for compliant ships at different compliant berths.

Additional annex:

Annex G (normative)

Additional requirements for vehicle carriers

G.1 General

Annex G describes the additional requirements to HVSC systems of vehicle carriers, meaning multi-deck roll-on, roll-off cargo ships designed to carry empty cars and trucks, other than those vessel types in Annex B.

The clause numbering of Annex G follows that of the main body of the text. Hence, the numbering is not necessarily continuous. Any content which is not explicitly mentioned applies, without modification. For example, G.4.1 refers to 4.1 in the main body.

G.4.1 System description

The general system diagram is shown in Figure G.1.

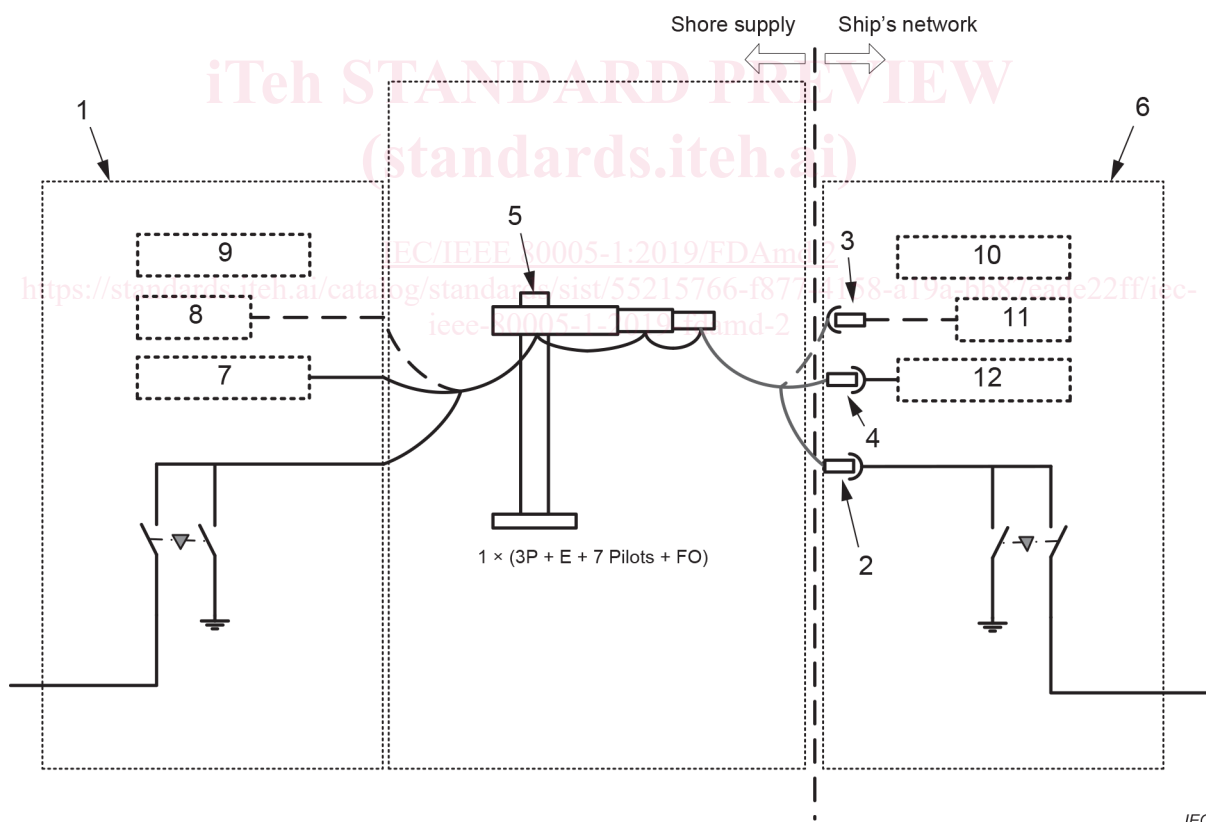

IEC

Key

- 1 shore supply system
- 2 ship connector (shore-side) and ship inlet (on-board)
- 3 fibre optic communication for control and monitoring (integrated in power cable); socket-outlet (shore-side) and plug (on-board) (this document does not specify requirements for optic communication)
- 4 pilot wires (integrated in plug and socket-outlet)
- 5 cable management system, here shown as shore-side crane
- 6 on-board shore connection switchboard
- 7 interlocks with pilot wire shore side

- 8 control shore side
- 9 protection relaying shore side
- 10 protection relaying ship side
- 11 control ship side
- 12 interlocks with pilot wire ship side

Figure G.1 – General system diagram

G.4.6.4 Electrical equipment in areas where flammable gas or vapour and/or combustible dust can be present

HVSC systems shall not be installed in areas which may become hazardous areas, such as car decks, upon failure of required air changes per hour during loading and offloading cargo or during normal operation.

G.5.1 Voltages and frequencies

The nominal voltage shall be 11 kV 60 Hz.

G.6.1 General

It is possible galvanic isolation is not required where a HV shore supply is dedicated to supply only ships which have galvanic isolation on board. A risk assessment shall be performed.

G.6.2.3 Neutral earthing resistor

Where a shore side transformer is used, the star point shall be earthed, through a neutral earthing resistor of 335 Ω .

G.7.1 General

[IEC/IEEE 80005-1:2019/FDAmd 2
https://standards.iteh.ai/catalog/standards/sist/55215766-f877-4158-a19a-bb87eade22ff/iec-](https://standards.iteh.ai/catalog/standards/sist/55215766-f877-4158-a19a-bb87eade22ff/iec-80005-1-2019/fdaamd-2)
Only one connector shall be used for HVSC. The maximum system demand shall be 6,5 MVA.

G.7.2.1 General

The cable management system shall be fitted at the shore side facility for vehicle carriers including pure car carriers (see Figure G.1).

Vehicle carriers that always have starboard side facing the quayside shall have the HVSC connection on the starboard side less than 100 m from the aft of the ship, alongside the quay. Figure G.2 shows the safety circuits.

The control power voltage shall be less than 60 V DC or 25 V AC safety extra-low voltage type source as per IEC 60364-4-41.

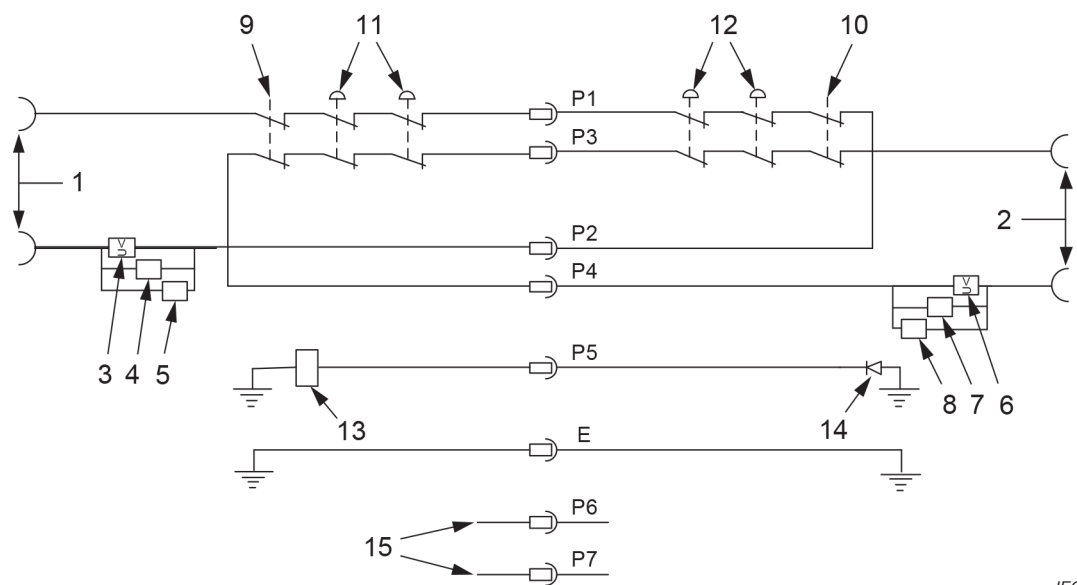

IEC

Key

- | | | | |
|---|--|----|---|
| 1 | control power pilot loop shore-side | 9 | control ES shore-side (emergency shutdown) |
| 2 | control power pilot loop on-board | 10 | control ES on-board (emergency shutdown) |
| 3 | circuit breaker undervoltage coil (shore-side) | 11 | manual ES shore-side (two shown) |
| 4 | safety circuit coil on shore-side | 12 | manual ES on-board (two shown) |
| 5 | earthing switch permission shore-side | 13 | equipotential bond monitoring device (where utilized) |
| 6 | circuit breaker undervoltage coil (on-board) | 14 | equipotential bond monitoring termination device (where utilized) |
| 7 | safety circuit coil on-board | 15 | spare pins/pilots |
| 8 | earthing switch permission on-board | E | earth (ground) connection (PE) |

P1 to P7 See key in Figure G.3.

NOTE Circuit breaker undervoltage coil (shore-side and on-board) can be directly connected to the safety circuit or through a safety relay (or equivalent).

Figure G.2 – Safety circuits

G.7.2.5 Equipotential bond monitoring

Equipotential bond termination device, where utilized, shall meet the following requirements:

- a) characteristic: Zener diode;
- b) Zener voltage: 5,6 V ± 0,03 V DC at 100 mA;
- c) forward voltage: 0,5 V ± 0,1 V DC at 100 mA;
- d) maximum impedance: 20 mΩ at 100 mA;
- e) operating temperature: -40 °C to 60 °C;
- f) current range: 2 mA to 25 A;
- g) frequency range: 0 kHz to 20 kHz, -3 db.

NOTE Other methods of monitoring the equipotential bond are acceptable (see 4.2.2).

G.7.3.1 General

General arrangement of ship connector and ship inlet shall be in accordance with IEC 62613-2:2016, Annex J, and Figure G.3 below.

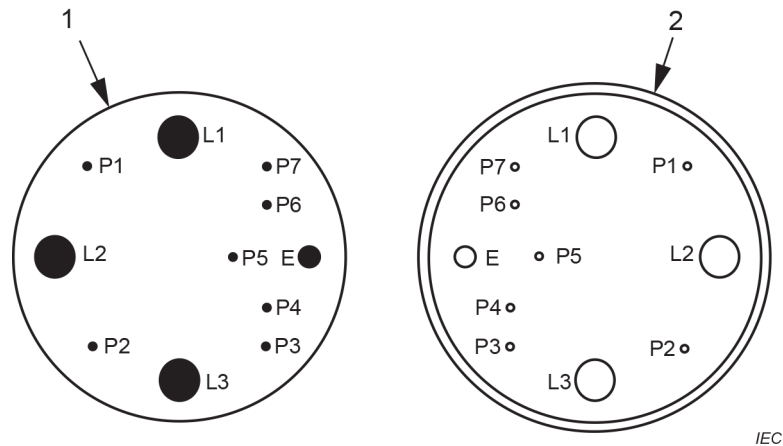

IEC

Key

1	ship connector face	P2	pilot line 2
E	earth	P3	pilot line 3
L1	phase A – phase R	P4	pilot line 4
L2	phase B – phase S	P5	pilot line 5
L3	phase C – phase T	P6	pilot line 6
2	ship inlet face	P7	pilot line 7
P1	pilot line 1		

Figure G.3 – Three-phase ship connector and ship inlet contact assignment

The short-circuit withstand current is 16 kA RMS for 1 s and a maximum peak short-circuit current of 40 kA (see IEC 62613-1).

Each connector and ship inlet shall be fitted with seven pilot contacts.

For design and dimensions, see IEC 62613-1 and IEC 62613-2:2016.

G.7.3.2 Pilot contacts

Pilot contacts are part of the safety circuit (see 4.9 and Figure G.2).

G.7.8 Data communication

If data-communication link is installed, data communication shall be performed utilizing fibre optic systems. Emergency shutdown functions shall be performed with pilot conductors (see IEC 62613-1, IEC 62613-2:2016, and Annex A).