



Designation: **F887 – 12^{e1} F887 – 13**

Standard Specifications for Personal Climbing Equipment¹

This standard is issued under the fixed designation F887; the number immediately following the designation indicates the year of original adoption or, in the case of revision, the year of last revision. A number in parentheses indicates the year of last reappraisal. A superscript epsilon (ϵ) indicates an editorial change since the last revision or reappraisal.

^{e1} NOTE—A Summary of Changes section was added editorially in December 2012.

1. Scope*

Table of Contents

<u>Section Title</u>	<u>Section/ Paragraph</u>
<u>Scope</u>	<u>1</u>
<u>Referenced Documents</u>	<u>2</u>
<u>Terminology</u>	<u>3</u>
<u>Significance and Use</u>	<u>4</u>
<u>Pole and Tree Climbers</u>	
<u>Classification</u>	<u>5</u>
<u>Ordering Information</u>	<u>6</u>
<u>Pole and Tree Climbers</u>	<u>7</u>
<u>Climber Gaffs</u>	<u>8</u>
<u>Climber Straps</u>	<u>9</u>
<u>Climber Pads</u>	<u>10</u>
<u>Climber Footplates</u>	<u>11</u>
<u>Body Belts, Positioning Devices and Wood Pole Fall Restrict Devices (WPFRD)</u>	
<u>Classification</u>	<u>12</u>
<u>Ordering Information</u>	<u>13</u>
<u>Body Belts</u>	<u>14</u>
<u>Positioning Devices</u>	<u>15</u>
<u>Wood Pole Fall Restriction Device (WPFRD)</u>	<u>16</u>
<u>Arborist Saddle</u>	
<u>Arborist Saddle</u>	<u>17</u>
<u>Harnesses</u>	
<u>Classification</u>	<u>18</u>
<u>Ordering Information</u>	<u>18.2</u>
<u>Sizing</u>	<u>18.3</u>
<u>Marking</u>	<u>18.4</u>
<u>Shock Absorbing Lanyards</u>	
<u>Classification</u>	<u>19</u>
<u>Ordering Information</u>	<u>20</u>
<u>Shock Absorbing Lanyards</u>	<u>21</u>
<u>Qualification Testing</u>	
<u>Electric Arc Performance</u>	<u>22</u>
<u>Qualification Testing (Test Equipment)</u>	<u>23</u>
<u>Body Belts, Positioning Devices</u>	
<u>Qualification Testing (WPFRD)</u>	<u>24</u>
<u>Qualification Testing (Arborist Saddle)</u>	<u>25</u>
<u>Instructions</u>	<u>26</u>
<u>Guarantee and Rejection</u>	<u>27</u>
<u>Keywords</u>	<u>28</u>

1.1 This standard covers the specifications and qualification testing of the following:

- Climbers,
- Climber straps,
- Climber Pads,
- Climber Footplates,
- Body Belts,

¹ These specifications are under the jurisdiction of ASTM Committee F18 on Electrical Protective Equipment for Workers and are the direct responsibility of Subcommittee F18.15 on Worker Personal Equipment.

Current edition approved Oct. 15, 2012 April 1, 2013. Published December 2012 June 2013. Originally approved in 1984. Last previous edition approved in 2011 as F887 – 11, F887 – 12^{e1}. DOI: 10.1520/F0887-12.10.1520/F0887-13.

*A Summary of Changes section appears at the end of this standard

Positioning Devices with Locking Snaphooks/Carabiners,
 Wood Pole Fall Restriction Devices (WPRD),
Arborist Saddle,
 Harnesses,
 Shock Absorbing Lanyards.

These devices are used by workers in the climbing of poles, trees, towers, and other structures. Minimum performance criteria for arc resistance of harnesses and shock absorbing lanyards are included for workers who may be exposed to thermal hazards of momentary electric arcs or flame.

1.2 Three types of climbers, ~~Types~~(Types A, B, and ~~C~~;C) and two types of climber straps, Types A(A and ~~B~~;B) are covered.

1.3 Two types of body belts, ~~Types~~(Types A and ~~B~~;B) are covered.

1.4 ~~Four~~Eight types of positioning devices: three positioning straps, ~~Types~~(Types A, B, and ~~C~~, and adjustable positioning lanyards-C), three adjustable-positioning lanyards, (Types A, B and C) and two nonadjustable positioning lanyards, (Types A and B) are covered.

1.5 Two types of WPRD, ~~Types~~(Types A and ~~AB~~;AB) are covered.

1.6 Arborist saddle, (Type A) Positioning and Suspension are covered.

1.7 Two types of harnesses, ~~Types~~(Types A and ~~B~~;B) are covered.

1.8 Two types of shock absorbing lanyards, ~~Types~~(Types A and ~~B~~;B) are covered.

1.9 The values stated in inch-pound units are to be regarded as standard. The values given in parentheses are mathematical conversions to SI units that are provided for information only and are not considered standard.

1.10 The following safety hazards caveat pertains only to the test method portions, [9.2](#), [10.3](#), [11.2](#), [14.4](#), [15.3](#), [15.4](#), ~~19.2~~[18.4](#), ~~22.2~~[21.2](#), ~~23.2~~[22](#), ~~24.2~~[23](#), and ~~25.2~~[24](#) of these specifications: *This standard does not purport to address all of the safety concerns, if any, associated with its use. It is the responsibility of the user of this standard to establish appropriate safety and health practices and determine the applicability of regulatory limitations prior to use.*

2. Referenced Documents

2.1 *ASTM Standards*:²

[B117 Practice for Operating Salt Spray \(Fog\) Apparatus](#)

[F1891 Specification for Arc and Flame Resistant Rainwear](#)

[F1958/F1958M Test Method for Determining the Ignitability of Non-flame-Resistant Materials for Clothing by Electric Arc Exposure Method Using Mannequins](#)

2.2 *ANSI/ASSE Standard*:³

~~Z359.0-2009~~[Z359.0-2012 Definitions and Nomenclature Used for Fall Protection and Fall Arrest](#)

[Z359.1 Safety Requirements for Personal Fall Arrest Systems, Subsystems and Components](#)

[Z359.3-2007 Safety Requirements for Positioning and Travel Restraint Systems](#)

[Z359.13-2009 Personal Energy Absorbers and Energy Absorbing Lanyards](#)

3. Terminology

3.1 *Definitions of Terms Specific to This Standard*:

3.1.1 *adjustable positioning lanyard (APL), n*—a component of a work positioning or fall restriction system (may be used for applications such as transitioning past an obstruction during ascent or descent).

3.1.2 *arborist saddle, n*—an arrangement of straps, fittings and buckles or other elements in the form of a waist belt with a low attachment suitably arranged to support the body in a sitting position. The arborist saddle may or may not include individual leg straps or a rigid batten seat section.

3.1.3 *attachment point, n*—specific connecting point on an arborist saddle for load bearing connection to other components, consisting of one or more attachment elements.

3.1.4 *fastening and adjusting element, n*—devices that enable an arborist saddle to be fastened and allow adjustment to be made to meet sizing requirements of the user.

3.1.5 *attachment element, n*—part or parts of an arborist saddle intended for the load bearing connection of other components.

3.1.6 *billet, n*—the free (buckle hole) end of a belt or strap as opposed to the buckle end, which is designed to pass through the buckle for closing.

² For referenced ASTM standards, visit the ASTM website, www.astm.org, or contact ASTM Customer Service at service@astm.org. For *Annual Book of ASTM Standards* volume information, refer to the standard's Document Summary page on the ASTM website.

³ Available from the American National Standards Institute, ANSI, 25 W. 43rd St., 4th Floor, New York, NY 10036.

3.1.7 *body belt attachment, n*—a system of straps and buckles which allow the harness wearer to use a body belt in conjunction with the harness.

3.1.8 *climber, n*—device used to assist in ascending and descending wood poles or trees. Climbers generally consist of leg iron, gaff, sleeves, straps and pads.

3.1.9 *dee-ring, D-ring, D-ring (body belt), n*—a steel straight-sided (no protrusions along edge of dee-ring; see Fig. 1) forging in a circle configuration with an integral stirrup to accept the belt, assembled into a body belt for the purpose of accepting the snaphooks of a positioning device.

3.1.10 *dee-ring, D-ring, (arborist saddle), n*—an element which allows for attaching a connecting device such as a carabiner or snaphook.

3.1.11 *design test, n*—for arc and flame resistant materials, one made on a sample treated as representative of an industrial product; these tests will not generally be repeated in quantity production.

3.1.12 *dripping, n*—in electric arc testing, a material response evidenced by flowing of the fiber polymer, the fabric, or the fabric coating, and the evidence of droplets from the material, that characterizes overall performance relative to reducing the transfer of heat that is sufficient to cause a second-degree burn.

3.1.13 *electric arc ignition, n*—as related to electric arc exposure, a response that causes the ignition of the material which is accompanied by heat and light, and then subsequent burning for at least 5 s, or consumption of at least 25 % of the exposed test specimen area.

3.1.14 *element, n*—an integral part of a constituent, component, hybrid component, sub-system or system. (Webbing, attachments and fittings are examples of elements.)

3.1.15 *fall arrest, n*—the action or event of stopping a free fall or the instant where the downward free fall has been stopped. (See ANSI Z359.0-2009; ANSI/ASSE Z359.0-2012.)

3.1.16 *fall restriction, n*—the act of preventing or limiting free fall from a work position, or while ascending or descending a wood pole.

3.1.17 *full body harness, n*—a component with a design of straps which is fastened about the person in a manner so as to contain the torso and distribute the fall arrest forces over at least the upper thighs, pelvis, chest, and shoulders with means for attaching it to other components or sub-systems.

3.1.18 *gaff, n*—a component of a pole or tree climber attached to the climber shank, similar to a spur, which is shaped to permit the secure penetration of the pole or tree trunk.

3.1.19 *keeper, n*—a component of the snaphook, used as a latching device and held in a closed position by a spring (see Fig. 2).

3.1.20 *leg iron, n*—a component of a pole or tree climber. The base or frame of the climber consisting of a shank and stirrup section. (see Fig. 3 for illustration of a leg iron with attached gaff and sleeve).

3.1.21 *length adjusting device (LAD), n*—a device designed to add or take up slack in an adjustable positioning lanyard so that the system will accommodate various circumferences.

3.1.22 *locking mechanism, n*—a component of the snaphook used in conjunction with the keeper to retain the keeper in a closed position until intentionally released and opened. A snaphook thus equipped, becomes a “locking snaphook.”

3.1.23 *locking snaphook, n*—a snaphook with a locking mechanism (see 3.1.163.1.22).

3.1.24 *nose, n*—the curved end of the snaphook which the keeper rests on. It is rounded and overlaps the keeper latch in such a manner as to prevent the dee-ring from inadvertently releasing the snaphook (see Fig. 2).

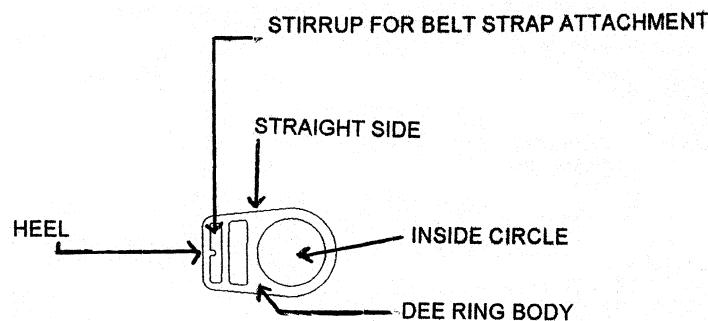

FIG. 1 Typical Body Belt Dee-Ring

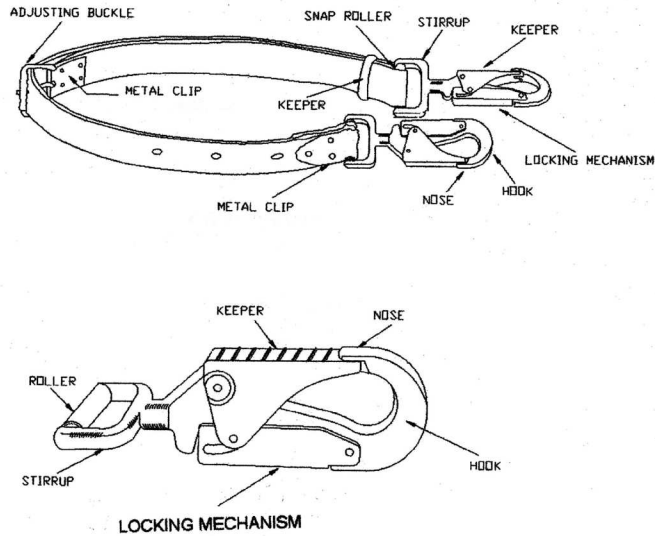

FIG. 2 Components of Positioning Strap

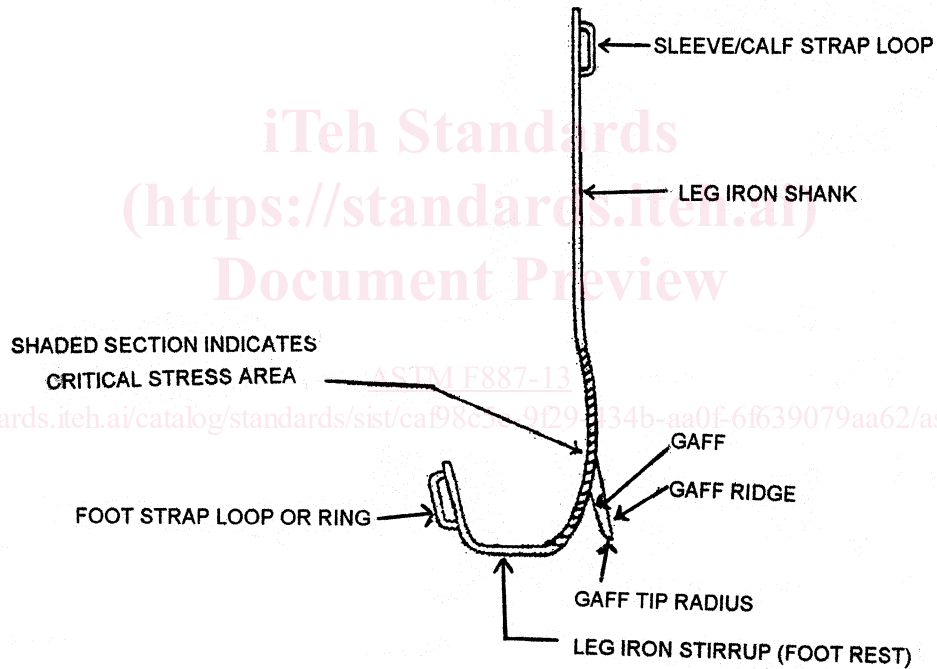

FIG. 3 Critical Stress Area of the Climber

3.1.25 *part (body belt), load-bearing, n*—a part of the body belt or positioning strap that, when in use with both snaphooks of the positioning strap engaged in one dee-ring of the body belt, will be required to support all or part of the mass of the user. This includes all the material in the positioning strap, and, in the case of the body belt, the material to which the dee-rings are directly fastened, and the material of the buckle strap that passes across the wearer's abdomen.

3.1.25.1 *Discussion*—

This definition and the strength requirements described in 15.3.2 are designed to ensure that the buckle strap is strong enough to withstand certain emergency conditions, but are not to be construed as approval of attaching both snaphooks to the same dee-ring when working aloft. OSHA Subpart M (1926.502) prohibits working with two load-bearing snaphooks in the same dee-ring unless snaphooks are of the locking type and designed for such application.

3.1.26 *part (harness), part, load bearing, (Type A and B harness), n*—a component of a harness to which arrest forces are directly transmitted in the event of a fall.

3.1.27 *part, load bearing, (positioning/restrict/suspension), n*—a component of the unit to which body weight forces are directly transmitted in the event of a fall.

3.1.28 *permanent deformation, n*—a deformation occurring beyond the yield point so that the structure will not return to its original dimensions after removal of the applied force.

3.1.29 *positioning lanyard, n*—a component of a climbing system consisting of a flexible line of rope or webbing generally with a connecting link at each end and may incorporate a length adjusting device to allow for adjustability.

3.1.30 *protector, gaff, n*—a cap or guard designed to cover the points of pole or tree gaffs to protect the gaffs from damage or from injuring people or from damaging equipment.

3.1.31 *positioning, n*—the act of supporting the user’s body with a positioning system for the purpose of working with hands free.

3.1.32 *positioning system, n*—a combination of positioning equipment defined by this standard intended for use in supporting a user in a work position with both hands free (i.e. climber, body belt or arborist saddle, WPRFD & APL etc.)

3.1.33 *shock absorbing lanyard, n*—a lanyard containing a component whose primary function is to dissipate energy and limit deceleration forces which the system imposes on the body during fall arrest.

3.1.34 *stirrup, climber, n*—the footrest of the pole or tree climber.

3.1.35 *stirrup, snaphook/dee-ring, n*—the closed rectangular portion of the positioning strap snaphook, or body belt dee-ring (see Fig. 1 and Fig. 2), that accepts the strap or belt material in a permanent manner.

3.1.36 *suspension, n*—the act of supporting a user’s body weight, including equipment, for the purpose of accessing a work location with one or two points of contact.

3.1.37 *wood pole fall restriction device (WPRFD), n*—a device that when properly adjusted and combined with other subcomponents and elements, allows the climber to remain at his or her work position with both hands free, and that performs a fall restriction function if the climber loses contact between his or her gaffs and the pole.

3.1.38 *work positioning, n*—the act of supporting the body with a positioning system for the purpose of working with hands free. (See ANSI Z359.0-2009.) ANSI/ASSE Z359.0-2012.)

4. Significance and Use

4.1 The following personal tools or equipment covered by these specifications are:

4.1.1 Climbers and climber straps used to ascend and descend poles and trees.

4.1.2 Body belts and positioning devices utilized for work positioning on poles, ladders, or structures.

4.1.3 WPRFD and adjustable positioning lanyards are used as components of a work positioning and fall restriction system and utilized in conjunction with a body belt.

4.1.4 Arborist saddle is intended for work positioning and suspension (ascent and descent) primarily in trees. The arborist saddle is not intended for use in fall arrest (See Fig. 4).

4.1.5 Full body harnesses and shock absorbing lanyards utilized in preventing and arresting falls.

4.2 Test methods included in these specifications are intended to provide uniform test procedures.

4.3 Snaphooks (non-locking)—(not permitted by this standard).

4.3.1 Locking snaphooks (required by this standard) manufactured to meet the requirements of these specifications, effectively prevent rollout from occurring and are able to be operated with one hand when working aloft.

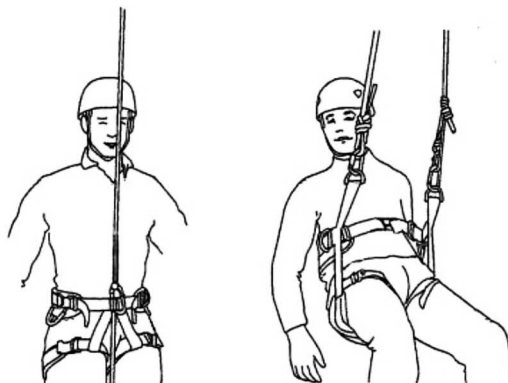

FIG. 4 Arborist Saddles, Shown in Typical Suspension Applications

4.4 Illustrations are furnished only to amplify the text. They are not to be considered restrictive as to specific design details, except where so stated.

4.5 Except for the restrictions set forth in these specifications because of design limitations, the use and maintenance of this equipment is beyond the scope of the standard.

4.5.1 For this type of protective equipment, it is common practice and the responsibility of the manufacturer to provide instructions regarding proper use, care and maintenance of the equipment and for the user's employer to provide training in and procedures for the safe use of such equipment.

POLE AND TREE CLIMBERS

5. Classification

5.1 Climbers covered under these specifications shall be designated as Type A, B, or C, as follows:

5.1.1 *Type A*—Fixed length, non-adjustable, with permanently attached gaffs.

5.1.2 *Type B*—Adjustable length, with permanently attached gaffs.

5.1.3 *Type C*—Adjustable length, with replaceable and interchangeable gaffs (that is, pole to tree) gaffs.

5.2 Climber straps covered under these specifications shall be designated as Type A or B, as follows:

5.2.1 *Type A*—One-piece straps that pass through the loops or rings on climbers and buckle one end to the other.

5.2.2 *Type B*—Two-piece ankle or bottom straps made so that each section can be attached to the climber ring, leaving the buckle end free to engage with the free billet end of the other piece.

6. Ordering Information

6.1 Orders for equipment under this specification shall include the following information:

6.1.1 Nomenclature,

6.1.2 Type,

6.1.3 Material,

6.1.4 Size, and

6.1.5 Gaff type (pole or tree).

6.2 The listing of equipment, types, and sizes is not intended to mean that all shall necessarily be available from the manufacturer; this listing signifies only that, if made, the equipment, types, and sizes shall conform to the details of these specifications.

7. Pole and Tree Climbers

7.1 *Sizes:*

7.1.1 Type A shall be available in sizes from 14 to 22 in. (355.6 to 558.8 mm) in ½ in. (12.7 mm) graduations.

7.1.2 Types B and C shall be available with the size adjustment capability of 14¾ to 21 in. (374.7 to 533.4 mm) by increments of ¼ in. (6.4 mm).

7.1.3 Adjustable climbers shall be equipped with positive locking, length-adjusting sections that can be double locked securely to the leg iron, permitting full compliance with standards established for fixed length climbers.

7.2 *Materials and Properties*—Leg irons manufactured utilizing quality alloy steel, aluminum or titanium alloys shall meet the performance requirements of this standard. SAE 4140, SAE 8630 and SAE 8640 steel alloys with quenched and tempered structure, 2014 T6 aluminum alloy and Ti6AL4V titanium alloy are recommended.

7.2.1 Materials other than those stated herein are permitted only when it can be demonstrated by testing that all applicable performance requirements of this standard are met and that the durability, reliability and other properties pertinent to the intended uses have been evaluated and determined suitable by testing. Any restrictions on the use of such leg irons shall be marked on the leg iron.

7.3 *Processing*—If required, manufacturers shall use a heat treatment to provide the required characteristics of the leg iron. Overheating shall be avoided. Scaling, pitting, and surface decarbonization shall be removed on the inside critical section of the leg iron from 2 in. (50.8 mm) below the gaff to 6 in. (152.4 mm) above the gaff (see Fig. 3).

7.4 *Design*—The design of the climber shall be such that the maximum tensile stress at the point where maximum stress occurs when subjected to a fluctuating bending force of 300 lbf (1.34 kN) applied to the center of the stirrup section with sleeve in position shall be as indicated in the table below. The climber shall be held in the climbing position by the gaff and at the top of the climber with the sleeve extended to provide a 16 in. (406.4 mm) length.

Leg Iron	Max Tensile Stress, psi (MPa)
Type A—Steel	27 000 (185)
Type B—Aluminum	9 000 (60)
Type C—Titanium	27 000 (185)

7.5 *Finish*—Leg irons shall be free of surface cracks and seams. All steel leg irons shall be finished with a rust-resistant coating.

TABLE 1 Typical Material Properties for Climbers

	For Fixed Gaff Climbers	For Replaceable Gaff Climbers ^A
<i>Steel:</i>		
Elongation in 2 in. (5 cm), min	14 %	14 % ^A
Hardness	23 to 38 HRC 243 to 353 HB ^B	32 to 40 HRC ^A 300 to 375 HB ^B
Yield strength, min, psi (MPa)	118 000 (815)	130 000 (895) ^A
<i>Aluminum:</i>		
Elongation in 2 in. (5 cm), min	...	10 %
Hardness	...	125 to 140 HB ^B
Yield Strength, min, psi (MPa)	...	65 000 (450)
<i>Titanium:</i>		
Elongation in 2 in. (5 cm), min	...	10 %
Hardness	...	30 to 40 HRC 286 to 371 HB ^B
Yield Strength, min, psi (MPa)	...	120 000 (828)

^A Data from Federal Specification RR-C-430 C. (Cancelled)

^B Brinell hardness number with 3000-kg load, 10-mm ball.

7.6 Testing, Inspection and Marking:

7.6.1 Testing:

7.6.1.1 *Deformation Test*—The purpose for this test is to aid in the elimination of climber failure in the event it is used in an unusual manner such as descending a pole with large steps. The climber shall be held rigidly in the climbing position with the top of the shank parallel to a mounting fixture, the stirrup freely suspended and perpendicular to the fixture. The climber equipped with a pole gaff must also be mounted at the gaff tip in a rigid surface to prevent gaff penetration. Gradually apply a static load of 750 lbf (3.3 kN) at the center of the stirrup and parallel to the fixture and hold for 3 min. Maximum deformation through any part of the climber shall not exceed 0.100 in. excluding measurement error after removal of the load. See Fig. 45.

7.6.1.2 *Fatigue Test*—When tested at room temperature (approx. 68°F), the climber as a minimum shall withstand without failure 100 000 cycles of a 300 lb (1334.5 N) load. The load must be applied parallel to the shank at the center of the stirrup section with sleeve in position. The climber equipped with a pole gaff shall be held in the climbing position by the gaff and at the top of the climber with the longest sleeve manufactured extended to provide maximum length. The gaff must be supported by a rigid surface so that the gaff will not penetrate the support. Failure shall be considered as any condition which renders the climber non-useable. See Fig. 56.

7.6.1.3 *Ductility Test*—(a) Leg iron: The leg iron shall withstand without fracture or cracking, a 180 degree bend about a 2-in. (51-mm) diameter mandrel near the midpoint of the shank area. Mandrel size shall be based upon the minimum allowable bend radius specified for the leg iron shank material, thickness and hardness properties. (b) Gaff: The gaff shall withstand, without fracture, a cold bend in a direction away from the leg iron. The center of the bend shall be approximately 5/8 in. (16 mm) from the tip of the gaff. Permanent deflection of the tip of 3/8 in. (9.5 mm) with respect to the straight outer edge of the upper section shall be produced.

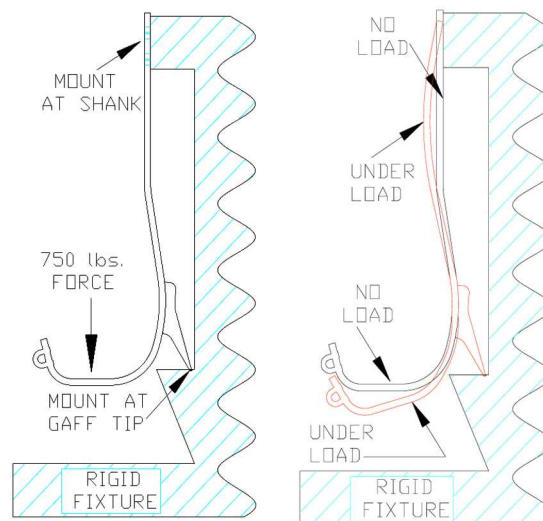

FIG. 45 Deformation Test Fixtures

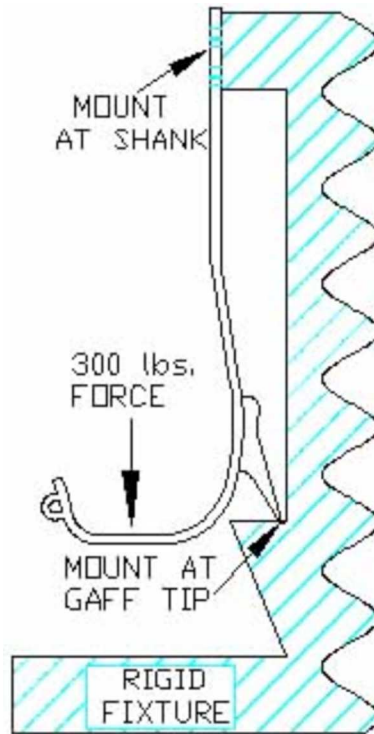

FIG. 56 Fatigue Test Fixture

7.6.1.4 *Plane Test*—This test may be used to determine that the gaff is correctly shaped and sharpened to properly penetrate the pole. Place the climber on a flat, soft pine or cedar board. Holding it upright with the shank parallel to the board surface, but with no pressure on the stirrup, push the climber forward along the board as shown in Fig. 67a. If the gaff is properly shaped and sharpened and if the gaff angle with the wood is sufficient, the gaff point will dig into the wood and begin to hold within a distance of approximately 1 in. (2.54 cm). If the climber gaff slides along the wood without digging in, or merely leaves a mark or groove in the wood as shown in Fig. 67b, the gaff is either not properly sharpened and shaped or the gaff angle is too small. The gaff angle is built into the climber by the manufacturer and should be between 11 and 17 degrees with the climber placed parallel to the surface of the wood.

7.6.1.5 *Pole Cut Out Test*—This test shall be performed on a section of a treated (that is, creosote, penta, etc.) pole in an area that is free from knots and checks. Place the climber on your leg holding the sleeve with your hand. With your leg at an approximate 30° angle to the pole and your foot about 12 in. (30.5 cm) off the ground. Lightly jab the gaff into the pole to a depth of approximately ¼ in. (6.4 mm). Keep enough pressure on the stirrup to keep the gaff in the pole but not so much as to cause the gaff to penetrate any deeper. See Fig. 78a. Push the climber and your hand closer to the pole by moving your knee until the strap loop of the climber sleeve is against the pole. Make certain the strap loop is held against the pole with pressure from your leg. Gradually exert full pressure of your foot straight down on the stirrup without raising your other foot off the floor or ground, so as to maintain balance if the gaff does not hold. See Fig. 78b. The tip of the gaff shall cut into the wood and hold (dig itself in) in a distance of not more than 2 in. (5.1 cm), measured from the point of gaff entry into the pole to the bottom of the cut on the pole surface.

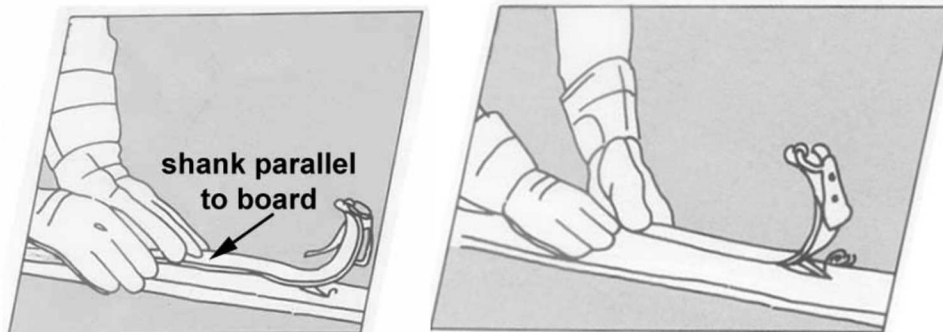

FIG. 67 a & b Plane Test

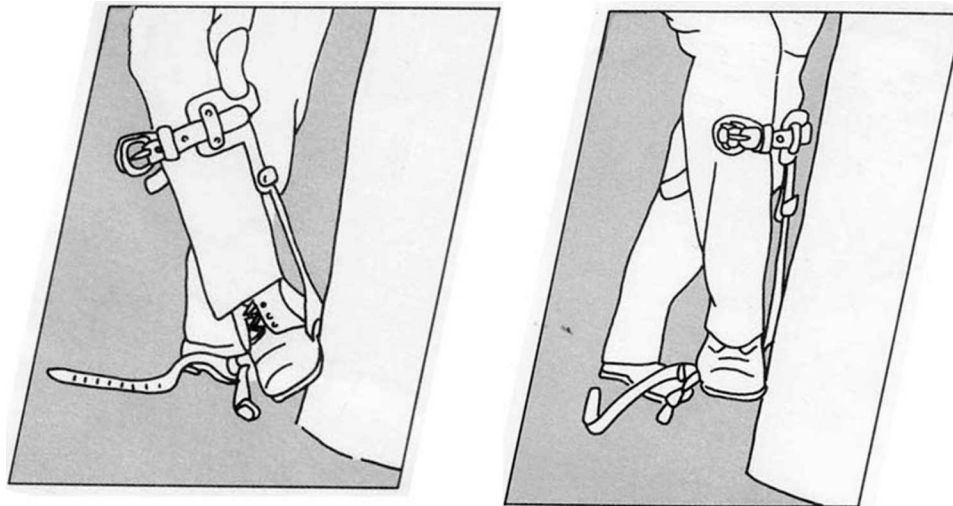

FIG. 78 a & b Pole Cut Out Test

7.6.2 All climbers shall be subjected to careful inspection by the manufacturer. When requested, the manufacturer shall provide certification that the climbers meet all requirements set forth in these specifications.

7.6.3 Completed climbers shall be permanently marked by the manufacturer with the manufacturer's name, ASTM F887 standard, size (if fixed size), right or left, and the month and year of manufacture. Right or left markings shall be in a visible area (that is, toe, stirrup) not covered by other equipment.

8. Climber Gaffs

8.1 *Sizes*—Pole gaffs shall measure at least $1\frac{7}{16}$ in. (36.5 mm) on the underside. Tree gaffs shall measure not more than $3\frac{1}{2}$ in. (88.9 mm), nor less than $2\frac{1}{4}$ in. (57.2 mm) on the underside. Gaff design shall be as shown in Fig. 89.

8.2 *Material*—All gaffs shall be forged of forging-quality steel having the properties listed in Table 2.

8.3 *Finish*:

8.3.1 All fins or burrs shall be removed from the cutting edges of gaff.

8.3.2 All gaffs shall be finished with a rust-resistant coating.

8.4 *Inspection*:

8.4.1 All gaffs shall be subjected to careful inspection by the manufacturer. When requested, the manufacturer shall certify that the gaffs meet all requirements set forth in these specifications.

8.4.2 The size and shape of gaffs shall be checked with a gauge available from the same manufacturer.

NOTE 1—Replaceable gaffs, whether pole or tree, fit only the climber iron of the particular manufacturer.

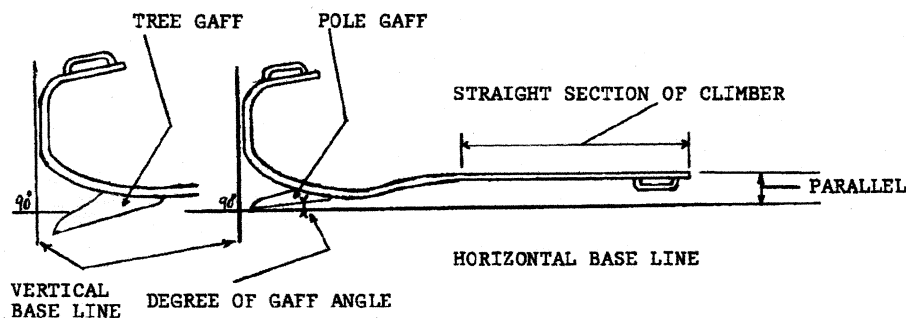

NOTE 1—Degree of angle of the gaff, measured as shown, shall range from 11° to 17° , and the point of the gaff shall be a minimum of $\frac{3}{8}$ in. (9.6 mm) above the lowest point of the climber stirrup. Tree gaffs are excluded from this requirement. The inside flat surface of the gaff at the tip shall be finished with a radius of approximately $\frac{1}{4}$ in. (6.4 mm) in accordance with the gage profile.

FIG. 89 Gaff Design

TABLE 2 Properties of Steel Alloy Acceptable for Gaffs

Elongation in 2 in. (5 cm), min	12 %
Hardness (tip)	45 to 55 HRC ^A 421 to 546 HB ^B
Yield strength, psi (MPa)	212 000 (1460)

^A There may be a variation of no more than three points in the Rockwell Hardness readings taken from the tip of the gaff to a point 1 ¼ in. (3.2 cm) back from the tip on the fixed gaff climber, 1 in. (2.5 cm) from the tip on replaceable gaff climbers.

^B Brinell hardness number with 3000-kg load, 10-mm ball.

9. Climber Straps

9.1 *Sizes*—Climber straps shall be a minimum of 1 in. (25.4 mm) in width and width. ~~¼ in. (3.18 mm) in thickness.~~ The length shall be not less than 22 in. (55.9 cm) for the calf strap, or 24 in. (61 cm) for the one-piece ankle strap. Two-piece ankle straps shall be not less than 24 in. (61 cm) in length.

9.2 *Material and Properties:*

9.2.1 Leather used in the manufacture of climber straps shall be top grain cowhide and shall have a breaking strength of not less than 450 lbf/in. (78.9 kN/m) of width with buckle holes. The buckle holding strength of leather shall be not less than 200 lbf (0.89 kN) static load when determined as follows:

9.2.1.1 Punch a hole ⅜ in. (4.76 mm) in diameter, centrally located in a 1 in. (25.4 mm) wide piece of strap, 1 in. (25.4 mm) from the end of the test piece. Into this hole, fit the tongue of a 1 in. assembled buckle of the design to be supplied with the climber strap. Apply the load to the buckle and to the free end of the strap. The buckle tongue shall not tear the leather under the specified static load of 200 lbf (0.89 kN).

9.2.2 The leather shall show no cracking on the grain side when bent slowly over a ½ in. (12.7 mm) diameter mandrel, grain side out, through an angle of 180°. The leather shall not show piping or wrinkling of the grain side when bent over a mandrel 1 in. (25.4 mm) in diameter, with the grain side in, through an angle of 180°.

9.2.3 Fabric used in the manufacture of climber straps shall have a breaking strength of not less than 600 lbf/in. (105.1 kN/m) of width with buckle holes. Construction shall be a minimum of four plies of thickness of folded nylon, or of woven nylon, or equivalent material, constructed in such a way that no raw edges are exposed. The folded fabric shall be impregnated with neoprene or its equivalent, so that the plies or strands are not readily separable, except by chemical means.

9.2.4 The buckle holding strength of the finished fabric strap shall be not less than 300 lbf (1.34 kN) static load without evidence of failure. Buckle tear shall be in the direction of load application when tested to failure.

9.3 *Hardware*—Buckle frames shall be of welded wire or forged construction. Tongues shall be of an adequate gage wire to meet the strength criteria of 9.2.

9.4 *Design*—Buckle holes in the climber straps shall not exceed ⅜ in. (4.76 mm) in diameter. Straps shall be riveted to the buckles by at least two rivets, with the strap keeper centered between the rivets. The completed assembly shall meet the strength requirements of 9.2. Buckle pads or chafes may be added when desired.

10. Climber Pads

10.1 Climber pad assemblies are intended for use with the climber to enhance comfort.

10.2 ~~Vetero~~Hook and Loop Fastener style wrap pads covered under these specifications cover the function of both the climber strap and pad.

10.3 *Materials*—Materials used in the manufacture of pads shall be of a type that will result in a finished product capable of meeting the requirements for this section outlined below.

10.3.1 Wrap style pads shall maintain a minimum wrap that shall not release at a force of less than 1000 lbf (4.45 kN) when statically tested.

10.3.2 Wrap style pads must display a minimum wrap location warning. Warning must be permanently attached (label or marking).

10.3.3 Sleeve retaining straps (see Fig. 910a) shall be a minimum of 1 in. (25.4 mm) in width. Leather sleeve retaining straps shall have a breaking strength of not less than 450 lbf/in. (78.9 kN/m) of width. Finished fabric sleeve retaining straps shall have a breaking strength of not less than 600 lbf/in. (105.1 kN/m) of width.

10.3.4 Sleeve retaining straps shall be capable of withstanding a direct pull of 175 lbf (0.78 kN). (See Fig. 910a).

10.3.5 Sleeve retaining straps in place within the climber sleeve shall be capable of withstanding a direct pull of 700 lbf (3.12 kN) (see Fig. 910b).

11. Climber Footplates

11.1 Climber footplate assemblies are intended for use with the climber to enhance comfort.

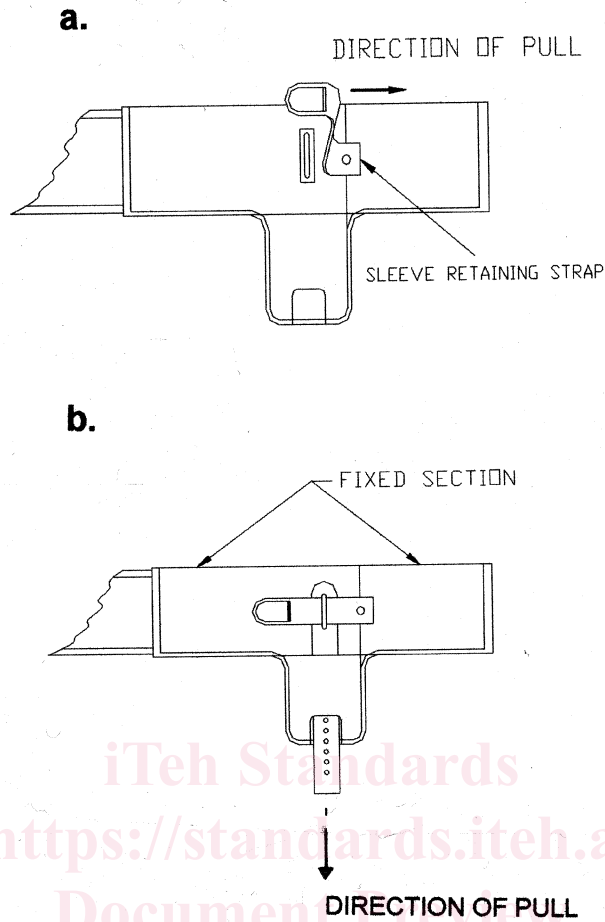

FIG. 910 a & b Sleeve Retaining Straps on Velcro-Hook and Loop Fastener Wrap Style Pads

11.2 *Materials and Properties*—Materials used in the manufacture of footplates shall be of a type that will result in a finished product capable of meeting the requirements for this section outlined below. Material used in the manufacture of footplates must maintain its integrity and resist permanent deformation under normal use conditions for the expected life of the product.

11.3 *Removable*—Footplates if removable shall be equipped with positive locking fasteners to secure the footplates to the climber stirrup.

11.4 *Articulation*—Footplates may swivel slightly on the climber stirrup to allow for ease of movement when working aloft.

11.5 *Shape*—Shape must be smaller than the outsole of a standard climbing boot while providing sufficient support to the outsole.

11.6 *Non-Skid*—Bottom surfaces of the footplate must be as a minimum 90 % covered by a rubber sole or an equivalent non-skid coating.

11.7 Steel footplates are not intended for and may not be used on aluminum climbers unless provisions are implemented to prevent premature wear on the climber.

11.8 Footplates shall be permanently marked by the manufacturer with the manufacturer's name, month and year of manufacture and designated as right and left.

11.9 *Finish*—Footplates shall be free of surface cracks and seams. All steel or ferrous material footplates shall be finished with a rust-resistant coating.

BODY BELTS, POSITIONING DEVICES AND WOOD POLE FALL RESTRICTION DEVICES (~~WPRFD~~)(WPRD)

12. Classification

12.1 Body belts covered under these specifications shall be designated as Type A or B, as follows:

12.1.1 *Type A*—Belt with dee-ring piece in fixed position.

12.1.2 *Type B*—Belt with dee-ring piece that has limited freedom of movement.

12.2 Positioning devices covered under this specification shall be designated as follows:

12.2.1 *Positioning Straps:*

12.2.1.1 *Type A*—Adjustable length, with tongue buckle.

12.2.1.2 *Type B*—Adjustable length, with friction buckle.

12.2.1.3 *Type C*—Nonadjustable length strap.

12.2.2 *Adjustable Positioning Lanyard:*

12.2.2.1 *Type A*—Adjustable length rope lanyard with Length Adjusting Device (LAD).

12.2.2.2 *Type B*—Web (woven nylon) lanyard with friction buckle, and buckle (see ANSI/ASSE Z359.3-2007).

12.2.2.3 *Type C*—6 to 10 ft retractable web/web (see ANSI/ASSE Z359.1-2007).

12.2.3 *Nonadjustable Positioning Lanyard:*

12.2.3.1 *Type A*—Nonadjustable Rope Lanyard (see ANSI/ASSE Z359.3-2007).

12.2.3.2 *Type B*—Nonadjustable Web Lanyard (see ANSI/ASSE Z359.3-2007).

12.3 WPF RD covered under these specifications shall be designated as Type A or AB as follows:

12.3.1 *Type A*—Equipment for use on dry, wet, conduit-covered poles as described in this specification.

12.3.2 *Type AB*—Equipment is for use on dry, wet, conduit-covered, and icy poles as described in this standard.

12.4 Arborist saddle covered under these specifications shall be designated as Type A, as follows:

12.4.1 *Type A*—Equipment for use in positioning and suspension.

13. Ordering Information

13.1 Orders for equipment under these specifications should include the following information:

13.1.1 Nomenclature,

13.1.2 Type,

13.1.3 Style,

13.1.4 Material, and

13.1.5 Size.

13.2 The listing of equipment, types, styles, and sizes is not intended to mean that all shall necessarily be available from the manufacturer. The listing signifies only that, if made, the equipment, types, styles, and sizes shall conform to the details of these specifications.

14. Body Belts

14.1 *Sizes*—The “dee” measurement will be the nominal distance from the heel or bar of one dee ring to the heel or bar of the other dee ring (see Fig. 4011). Body belts shall be marked with the “dee” sizes since the dee size is the most critical. Body belts are normally furnished in the combination belt strap and dee sizes listed in Table 3 (see Fig. 412), however, belt strap measurements may vary on different style belts and with different manufacturers.

14.2 *Materials:*

14.2.1 *Leather*—Top grain leather or leather substitute may be used in the manufacture of body belts and accessories, but shall not be used alone as a load bearing component of the assembly.

14.2.2 *Fabric*—Plied fabric used in the manufacture of load bearing parts of body belts shall be constructed in such a way that no raw edges are exposed. Plied fabric shall be impregnated with neoprene, or its equivalent, so that the plies are not readily separable, except by chemical means. If webbing is used, it need not be impregnated.

14.3 *Design:*

14.3.1 *Body Pad*—The cushion part of the body belt shall contain no exposed rivets on the inside and shall be at least 3 in. (76.2 mm) in width. The belt shall have pocket tabs extending at least 1 1/2 in. (38.1 mm) down, and with the point of attachment at least 3 in. (76.2 mm) back of inside of the circle of dee-rings on each side for attachment of plier or tool pockets (see Fig. 4213). On shifting dee belts, the measurement for pocket tabs shall be taken when the dee ring section is centered.

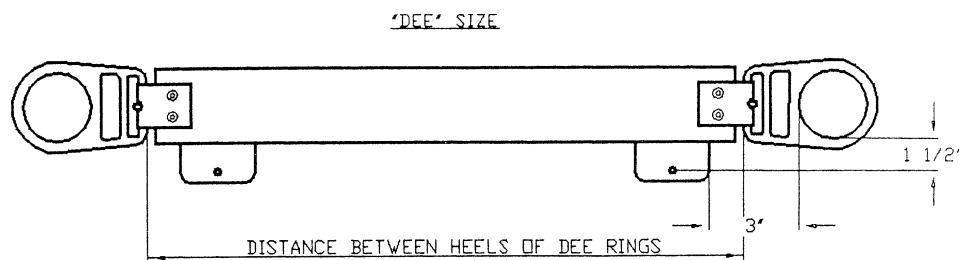

FIG. 4011 “Dee” Measurement