



Designation: **B212—12 B212 – 13**

Standard Test Method for Apparent Density of Free-Flowing Metal Powders Using the Hall Flowmeter Funnel¹

This standard is issued under the fixed designation B212; the number immediately following the designation indicates the year of original adoption or, in the case of revision, the year of last revision. A number in parentheses indicates the year of last reapproval. A superscript epsilon (ϵ) indicates an editorial change since the last revision or reapproval.

This standard has been approved for use by agencies of the Department of Defense.

1. Scope*

1.1 This test method describes a procedure for determining the apparent density of free-flowing metal powders, and mixed powders; and is suitable for only those powders that will flow unaided through the specified Hall Flowmeter funnel.

1.2 With the exception of the values for mass, volume, and density, for which the use of the gram and the cubic centimeter units is the long-standing industry practice, the values stated in inch-pound units are to be regarded as standard. The values given in parentheses are mathematical conversions to SI units that are provided for information only and are not considered standard.

1.3 *This standard does not purport to address all of the safety concerns, if any, associated with its use. It is the responsibility of the user of this standard to establish appropriate safety and health practices and determine the applicability of regulatory limitations prior to use.*

2. Referenced Documents

2.1 *ASTM Standards:*²

[B215 Practices for Sampling Metal Powders](#)

[B243 Terminology of Powder Metallurgy](#)

[B873 Test Method for Measuring Volume of Apparent Density Cup Used in Test Methods B 212, B 329, and B 417](#)

[E691 Practice for Conducting an Interlaboratory Study to Determine the Precision of a Test Method](#)

3. Terminology

3.1 *Definitions*—For definitions of terms used in this test method, see Terminology [B243](#). Additional descriptive PM information is available in the Related Materials section of [Vol. 02.05](#) of the Annual Book of ASTM Standards.

4. Summary of Test Method

4.1 A volume of powder is permitted to flow into a container of definite volume under controlled conditions. The mass of powder per unit volume is determined and reported as apparent density, Hall (AD_H).

5. Significance and Use

5.1 This test method provides a guide for evaluation of an important physical characteristic of a powder known as the apparent density. The measured apparent density bears a relationship to the mass of powder that will fill a fixed volume die cavity. The degree of correlation between the results of this test and the performance of powders during use may vary with each particular application. Note, however, that the presence of moisture, oils, stearic acid, stearates, waxes, and the temperature of the powder mass may alter the physical characteristics of the powder.

¹ This test method is under the jurisdiction of ASTM Committee [B09](#) on Metal Powders and Metal Powder Products and is the direct responsibility of Subcommittee [B09.02](#) on Base Metal Powders.

Current edition approved April 1, 2012; April 1, 2013. Published September 2012; June 2013. Originally approved in 1946. Last previous edition approved in 2009 as [B212 – 09](#); [B212 – 12](#). DOI: [10.1520/B0212-12](#); [10.1520/B0212-13](#).

² For referenced ASTM standards, visit the ASTM website, [www.astm.org](#), or contact ASTM Customer Service at [service@astm.org](#). For *Annual Book of ASTM Standards* volume information, refer to the standard's Document Summary page on the ASTM website.

*A Summary of Changes section appears at the end of this standard

6. Apparatus

6.1 Powder Flowmeter Funnel³—A Hall Flowmeter funnel (Fig. 1) having a calibrated orifice.

6.2 Density Cup³—A cylindrical brass cup (Fig. 2) having a nominal capacity of 25 cm³. The actual cup volume shall be determined according to Test Method B873. If the measured volume of the cup is outside the tolerance in Fig. 2 (25 ± 0.03 cm³) the cup shall not be used.

6.3 Stand³—A stand (Fig. 1) to support the Hall Flowmeter funnel concentric with the density cup so that the bottom of the Hall Flowmeter funnel orifice is approximately 25 mm (1 in.) above the top of the density cup when the apparatus is assembled as shown in Fig. 1.

6.4 Workbench—A level, vibration-free table or workbench to support the powder flowmeter stand.

6.5 Balance—A balance, readable to 0.001 g, having a capacity of at least 200 g capable of determining the mass to the nearest 0.01 g.

6.6 Spatula or straight edge—A non-magnetic spatula or straight edge of suitable dimensions for leveling off the excess powder on top of the density cup.

7. Test Portion

7.1 The test portion shall consist of a volume of approximately 30 to 40 cm³ of metal powder obtained in accordance with Practices B215.

³ The sole source of supply of the apparatus known to the committee at this time is ACuPowder International, LLC, 901 Lehigh Ave., Union, NJ 07083-7632. If you are aware of alternative suppliers, please provide this information to ASTM International Headquarters. Your comments will receive careful consideration at a meeting of the responsible technical committee,¹ which you may attend.

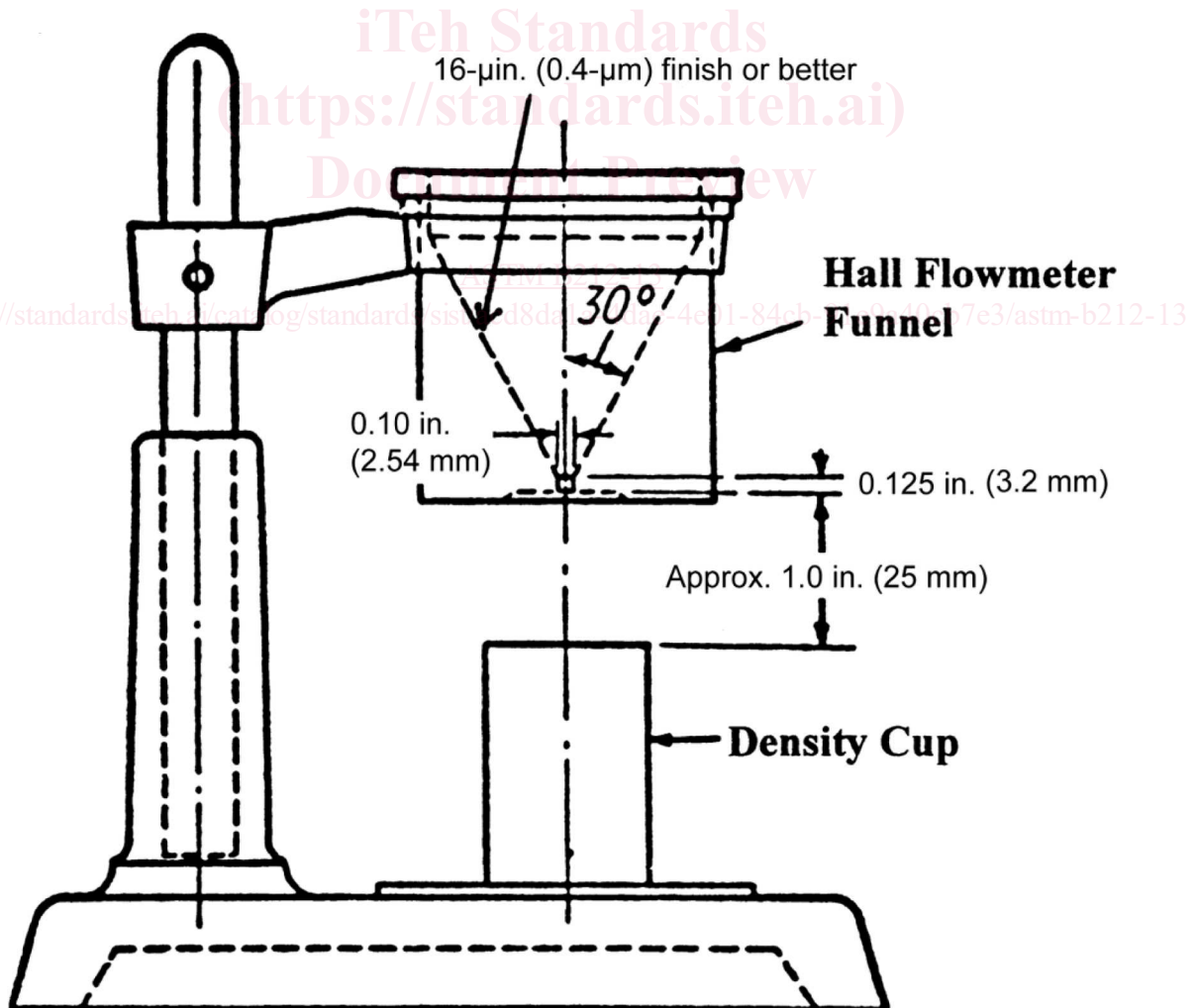

FIG. 1 Flowmeter Apparatus — Hall Funnel