



Designation: **B213—11 B213 – 13**

# Standard Test Methods for Flow Rate of Metal Powders Using the Hall Flowmeter Funnel<sup>1</sup>

This standard is issued under the fixed designation B213; the number immediately following the designation indicates the year of original adoption or, in the case of revision, the year of last revision. A number in parentheses indicates the year of last reapproval. A superscript epsilon ( $\epsilon$ ) indicates an editorial change since the last revision or reapproval.

*This standard has been approved for use by agencies of the Department of Defense.*

## 1. Scope\*

1.1 This test method covers the determination of a flow rate, by the use of the Hall Flowmeter funnel of metal powders and powder mixtures. It is suitable only for those powders that will flow unaided through the Hall Flowmeter funnel.

1.2 With the exception of the values for density and the mass used to determine density, for which the use of the gram per cubic centimeter ( $\text{g}/\text{cm}^3$ ) and gram (g) units is the ~~longstanding~~ long-standing industry practice, the values in inch-pound units are to be regarded as standard. The values given in parentheses are mathematical conversions to SI units that are provided for information only, and are not considered standard.

1.3 *This standard does not purport to address all of the safety concerns, if any, associated with its use. It is the responsibility of the user of this standard to establish appropriate safety and health practices and determine the applicability of regulatory limitations prior to use.*

## 2. Referenced Documents

2.1 *ASTM Standards:*<sup>2</sup>

[B215 Practices for Sampling Metal Powders](#)

[B243 Terminology of Powder Metallurgy](#)

[B855 Test Method for Volumetric Flow Rate of Metal Powders Using the Arnold Meter and Hall Flowmeter Funnel](#)

[B964 Test Methods for Flow Rate of Metal Powders Using the Carney Funnel](#)

## 3. Terminology

3.1 *Definitions*—Definitions of powder metallurgy terms can be found in Terminology [B243](#).

3.2 *Definitions of Terms Specific to This Standard:*

3.2.1 *Hall flow rate ( $FR_H$ ), n*—the time required for a metal powder sample of specified mass to flow through the orifice in a Hall Flowmeter funnel according to a specified procedure.

## 4. Summary of Test Method

4.1 A weighed mass (50.0 g) of metal powder is timed as it flows through the calibrated orifice of a Hall Flowmeter funnel.

## 5. Significance and Use

5.1 The rate and uniformity of die cavity filling are related to flow properties, which thus influence production rates and uniformity of compacted parts.

5.2 The ability of a powder to flow is a function of interparticle friction. As interparticle friction increases, flow is slowed. Fine powders may not flow. Some powders, often fine powders and lubricated powder mixtures, may not flow through the Hall Flowmeter funnel. Nevertheless, if a larger orifice is provided, such as in the Carney Flowmeter funnel of Test Method [B964](#), a meaningful flow rate may be determined, providing specific information for certain applications.

<sup>1</sup> This test method is under the jurisdiction of ASTM Committee [B09](#) on Metal Powders and Metal Powder Products and is the direct responsibility of [B09.02](#) on Base Metal Powders.

Current edition approved Nov. 15, 2011/April 1, 2013. Published December 2011/June 2013. Originally approved in 1946. Last previous edition approved in 2003/2011 as [B213—03](#); [B213 – 11](#). DOI: [10.1520/B0213-11](#); [10.1520/B0213-13](#).

<sup>2</sup> For referenced ASTM standards, visit the ASTM website, [www.astm.org](#), or contact ASTM Customer Service at [service@astm.org](#). For *Annual Book of ASTM Standards* volume information, refer to the standard's Document Summary page on the ASTM website.

\*A Summary of Changes section appears at the end of this standard

5.3 Test Method ~~B213~~<sup>B213.2</sup>, using the Hall Flowmeter funnel, is the preferred method for determining the flowability of metal powders and powder mixtures. The Carney Flowmeter funnel of Method ~~B964~~ should only be used when powder will not flow through the Hall Flowmeter funnel.

5.4 Humidity and moisture content influence flow rate. Wet or moist powders may not flow.

5.5 These test methods are based on flow of a specified mass of powder. If flow of a specific volume of powder is preferred, Test Method ~~B855~~ may be used for powders that flow readily through the Hall Flowmeter funnel.

5.6 This test method may be part of the purchase agreement between powder manufacturers and powder metallurgy (PM) part producers, or it can be an internal quality control test by either the producer or the end user.

## 6. Apparatus

6.1 *Powder Flowmeter Funnel*<sup>3</sup>—A flowmeter funnel (Fig. 1) having a calibrated orifice of 0.10 in. (2.54 mm) in diameter.

6.2 The dimensions shown for the flowmeter funnel, including the orifice, are not to be considered controlling factors. Calibration with emery, as specified in Section 9, determines the working flow rate of the funnel.

6.3 *Stand*<sup>3</sup>—A stand (Fig. 2) to support the powder flowmeter funnel.

6.4 *Workbench*—A level, vibration free table or workbench to support the powder flowmeter stand.

6.5 *Timing Device*—A stopwatch or other suitable device capable of measuring to the nearest 0.1 s.

6.6 *Chinese Emery*<sup>3</sup>—An emery powder used to calibrate the flowmeter funnel.

6.7 *Balance*—A balance readable to 0.01 g suitable for weighing at least 50.0 g to the nearest 0.1 g.

## 7. Sampling

7.1 A test sample of powder sufficient to run the desired number of flow tests shall be obtained in accordance with Practice ~~B215~~.

7.2 Individual test portions, each of approximately the required mass, shall be obtained from the test sample in accordance with Practice ~~B215~~.

## 8. Preparation of Apparatus

8.1 Clean the funnel with clean dry toweling paper.

8.2 Clean the funnel orifice with a clean dry pipe cleaner.

## 9. Calibration of Apparatus

9.1 The manufacturer supplies the powder flowmeter funnel calibrated as follows:

9.1.1 Heat an open glass jar of Chinese emery in a drying oven at a temperature of 102° to 107°C (215° to 225°F) ~~225~~ °F) for 1h.

9.1.2 Cool the emery to room temperature in a ~~dessicator~~ desiccator.

9.1.3 Follow the procedure outlined in steps 10.1.1-10.1.8.

9.1.4 Repeat steps 10.1.2-10.1.8 using the identical 50.0 g mass of emery for all the tests until 5 flow times, the extremes of which shall not differ by more than 0.4 s, have been recorded.

NOTE 1—The flow rate of Chinese emery calibration powder is sensitive to moisture. Starting from the dried condition, it will absorb moisture from the ambient air as five (or more) flow tests are performed. Flow times can vary dependent upon the humidity of the test area.

9.1.5 The average of these five flow times is stamped on the bottom of the funnel. The correction factor for the unused flowmeter funnel is 40.0 divided by this number.

9.2 The flow rate of Chinese emery powder was established by an interlaboratory study conducted by Subcommittee B09.02 in 1995.<sup>4</sup> The value was 40.0. It represents the flow rate through the master flowmeter funnel that had been used in a previous interlaboratory study with the former Turkish emery calibration powder, which is no longer available.

9.3 It is recommended that the flow rate be checked periodically, at least every six months, using the procedure outlined in steps 9.1.1-9.1.5. If the flow rate has changed from that stamped on the instrument, the new correction factor will be 40.0 divided by this new flow rate. Before adopting the new correction factor, however, it is recommended that the cause of the change be investigated. If the flow rate has increased (faster flow), it is probable that repeated use has burnished the orifice and the new correction factor may be used. A decrease in flow rate (slower flow) may indicate a plating of soft powder upon the orifice. This

<sup>3</sup> The flowmeter funnel, stand, and Chinese emery are available from ~~AcuPowder~~ AcuPowder International, LLC.

<sup>4</sup> Supporting data is available from ASTM Headquarters.

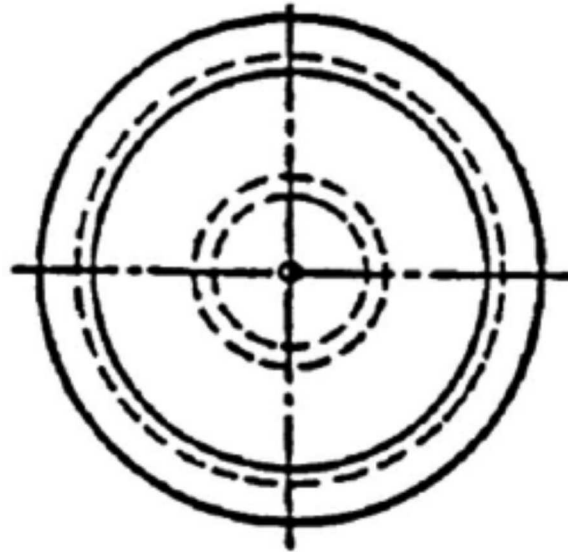

16 microinch ( $0.4 \times 10^{-6}$  m) finish or better

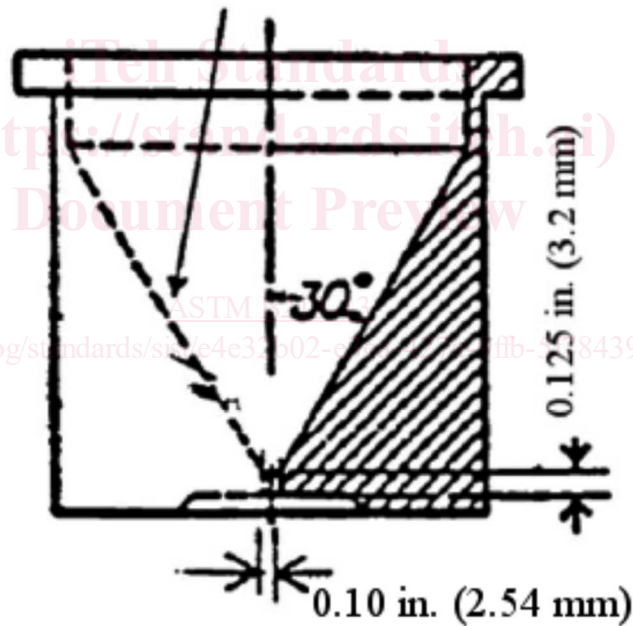

FIG. 1 Hall Flowmeter Funnel

should be removed carefully with the aid of a pipe cleaner and the calibration test rerun, the new correction factor being calculated if required. It is recommended that the use of a funnel be discontinued after the flow rate of the emery has increased such that the time of flow is less than 37 s.

**10. Procedure**

10.1 *Method 1—Stationary Powder Start to Flow Measurement (Static Flow Method):*

- 10.1.1 Weigh out a 50.0 g mass of powder, as sampled, into a clean weighing dish.
- 10.1.2 Block the discharge orifice at the bottom of the funnel with a dry finger.
- 10.1.3 Carefully pour the 50.0 g sample of powder into the center of the flowmeter funnel without any tapping, vibration or movement of the funnel.
- 10.1.4 Place the emptied weighing dish on the flowmeter stand directly under the funnel orifice.
- 10.1.5 Simultaneously start the timing device and remove your finger from the discharge orifice.