



Designation: B311 – 13

Standard Test Method for Density of Powder Metallurgy (PM) Materials Containing Less Than Two Percent Porosity¹

This standard is issued under the fixed designation B311; the number immediately following the designation indicates the year of original adoption or, in the case of revision, the year of last revision. A number in parentheses indicates the year of last reapproval. A superscript epsilon (ϵ) indicates an editorial change since the last revision or reapproval.

This standard has been approved for use by agencies of the U.S. Department of Defense.

1. Scope*

1.1 This test method covers the determination of density for powder metallurgy (PM) materials containing less than two percent porosity and for cemented carbides. This test method is based on the water displacement method.

NOTE 1—A test specimen that gains mass when immersed in water indicates the specimen contains surface-connected porosity. Unsealed surface porosity will absorb water and cause density values higher than the true value. This test method is not applicable if this problem occurs.

1.2 With the exception of the values for density and the mass used to determine density, for which the use of the gram per cubic centimeter (g/cm^3) and gram (g) units is the long-standing industry practice, the values in SI units are to be regarded as standard.

1.3 *This standard does not purport to address all of the safety concerns, if any, associated with its use. It is the responsibility of the user of this standard to establish appropriate safety and health practices and determine the applicability of regulatory limitations prior to use.*

2. Referenced Documents

2.1 *ASTM Standards:*²

B243 Terminology of Powder Metallurgy

E691 Practice for Conducting an Interlaboratory Study to Determine the Precision of a Test Method

E456 Terminology Relating to Quality and Statistics

3. Terminology

3.1 Definitions of powder metallurgy (PM) terms can be found in Terminology **B243**. Additional descriptive material is

¹ This test method is under the jurisdiction of ASTM Committee **B09** on Metal Powders and Metal Powder Products and is the direct responsibility of Subcommittee **B09.11** on Near Full Density Powder Metallurgy Materials.

Current edition approved April 1, 2013. Published June 2013. Originally approved in 1956. Last previous edition approved in 2008 as B311–08. DOI: 10.1520/B0311-13.

² For referenced ASTM standards, visit the ASTM website, www.astm.org, or contact ASTM Customer Service at service@astm.org. For *Annual Book of ASTM Standards* volume information, refer to the standard's Document Summary page on the ASTM website.

available in the Related Material section of Vol. 02.05 of the *Annual Book of ASTM Standards*.

4. Summary of Test Method

4.1 Using an analytical balance, the test specimen is first weighed in air and then in water. The density is determined by calculation using Archimedes' principle.

5. Significance and Use

5.1 For PM materials containing less than two percent porosity, a density measurement may be used to determine if the part has been densified, either overall or in a critical region, to the degree required for the intended application. Density alone cannot be used for evaluating the degree of densification because chemical composition and heat treatment affect the pore-free density.

5.2 For cemented carbides, a density measurement is normally used to determine if there is any significant deviation in composition of the carbide grade. For straight tungsten carbide-cobalt grades, the relationship is straightforward. For complex carbide grades (for example, grades containing tantalum carbide or titanium carbide, or both, in addition to tungsten carbide-cobalt), the situation is more complicated. If the measured density is beyond the specified limits, the composition is outside of the specified limits. A measured density within the specified limits does not ensure correct composition; compensation between two or more constituents could result in the expected density with the wrong composition. Density alone cannot be used for evaluating a cemented carbide grade.

6. Apparatus

6.1 *Analytical Balance*—precision single-pan analytical balance that will permit readings within 0.01% of the test specimen mass. The analytical balance shall be supported in a manner to eliminate mechanical vibrations and be shielded from air drafts. See **Table 1**.

6.2 *Weighing Liquid*—Distilled or deionized water to which 0.05 to 0.1 volume percent of a wetting agent has been added to reduce the effects of surface tension.

*A Summary of Changes section appears at the end of this standard

TABLE 1 Balance Sensitivity

Mass, g	Balance Sensitivity, g
less than 10	0.0001
10 to less than 100	0.001
100 to less than 1000	0.01
1000 to less than 10 000	0.1

TABLE 2 Maximum Recommended Wire Diameter

Mass, g	Wire Diameter, mm
less than 50	0.12
50 to less than 200	0.25
200 to less than 600	0.40
600 and greater	0.50

NOTE 2—Degassing the water by evacuation, boiling, or ultrasonic agitation helps to prevent air bubbles from collecting on the test specimen and specimen support when immersed in water.

6.3 *Water Container*—A glass beaker or other suitable transparent container should be used to contain the water.

NOTE 3—A transparent container makes it easier to see air bubbles adhering to the test specimen and specimen support when immersed in water.

NOTE 4—For the most precise density determination, the water container should be of a size that the level of the water does not rise more than 2.5 mm when the test specimen is lowered into the water.

6.4 *Test Specimen Support for Weighing in Water*—Two typical arrangements are shown in Fig. 1. The suspension wire may be twisted around the test specimen or the test specimen may be supported in a wire basket that is attached to the suspension wire. For either arrangement, a single corrosion resistant wire—for example, austenitic stainless steel, copper, nichrome—shall be used for the basket and suspension wire. For the maximum recommended diameter of suspension wire to be used for various mass ranges see Table 2.

NOTE 5—For the most precise density determinations, it is important that the mass and volume of all supporting wires immersed in water be minimized.

6.5 *Thermometer*—A thermometer with an accuracy of 0.2 °C to measure the temperature of the water.

7. Preparation of Test Specimens

7.1 A complete part or a section of a part may be used for the test specimen. For the highest precision, the test specimen shall have a minimum mass of 5.0 g. If less precision can be tolerated, several test specimens may be used to reach the minimum mass, provided each test specimen has a mass of not less than 1.0 g.

7.2 All test specimen surfaces shall be thoroughly cleaned of all adhering foreign materials, such as, dirt, grease, oil, oxide scale, metal powders or assembly materials. For cut

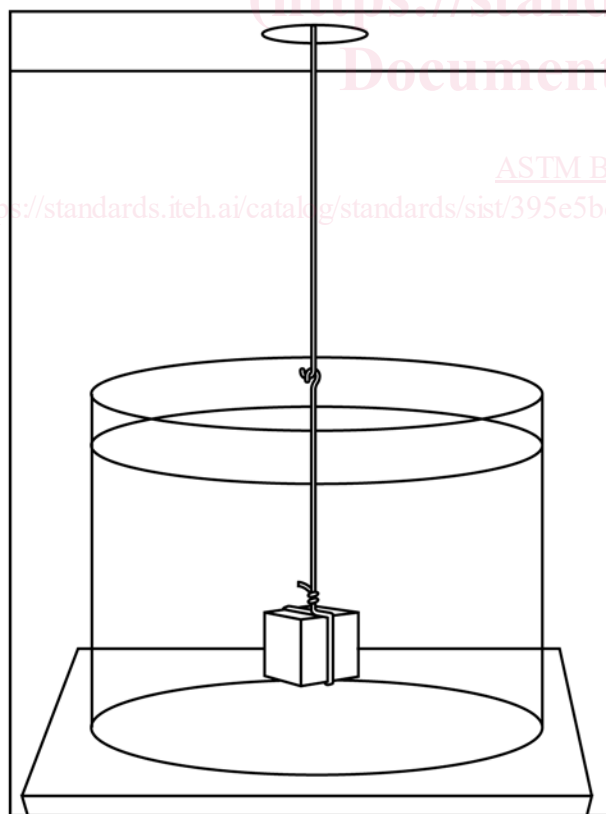

(a) Twisted wire arrangement

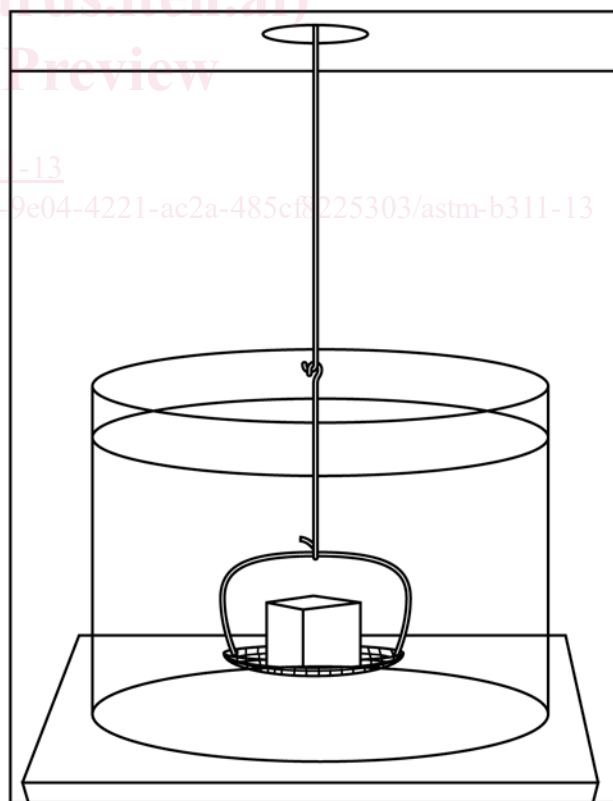

(b) Basket support arrangement

FIG. 1 Methods for Holding the Test Specimen When Weighing in Water