



Designation: **A781/A781M – 12b** A781/A781M – 13

Standard Specification for Castings, Steel and Alloy, Common Requirements, for General Industrial Use¹

This standard is issued under the fixed designation A781/A781M; the number immediately following the designation indicates the year of original adoption or, in the case of revision, the year of last revision. A number in parentheses indicates the year of last reapproval. A superscript epsilon (ϵ) indicates an editorial change since the last revision or reapproval.

1. Scope*

1.1 This specification covers a group of requirements that are mandatory requirements of the following steel casting specifications issued by ASTM. If the product specification specifies different requirements, the product specification shall prevail.

ASTM Designation	Title of Specification
A27/A27M	Steel Castings, Carbon, for General Application
A128/A128M	Steel Castings, Austenitic Manganese
A148/A148M	Steel Castings, High Strength, for Structural Purposes
A297/A297M	Steel Castings, Iron-Chromium and Iron-Chromium-Nickel, Heat Resistant for General Application
A447/A447M	Steel Castings, Chromium-Nickel-Iron Alloy (25-12 Class), for High-Temperature Service
A494/A494M	Castings, Nickel and Nickel Alloy
A560/A560M	Castings, Chromium-Nickel Alloy
A743/A743M	Castings, Iron-Chromium, Iron-Chromium-Nickel, Corrosion Resistant, for General Application
A744/A744M	Castings, Iron-Chromium-Nickel, Corrosion Resistant, for Severe
A747/A747M	Steel Castings, Stainless, Precipitation Hardening
A890/A890M	Castings, Iron-Chromium-Nickel-Molybdenum Corrosion-Resistant, Duplex (Austenitic/Ferritic) for General Application
A915/A915M	Steel Castings, Carbon and Alloy, Chemical Requirements Similar to Standard Wrought Grades
A958	Steel Castings, Carbon and Alloy, with Tensile Requirements, Chemical Requirements Similar to Standard Wrought Grades
A1002	Castings, Nickel-Aluminum Ordered Alloy

1.2 This specification also covers a group of supplementary requirements that may be applied to the above specifications as indicated therein. These are provided for use when additional testing or inspection is desired and apply only when specified individually by the purchaser in the order.

1.3 The requirements of the individual material specification, and this general specification shall prevail in the sequence named.

1.4 The values stated in either SI units or inch-pound units are to be regarded separately as standard. The values stated in each system may not be exact equivalents; therefore, each system shall be used independently of the other. Combining values from the two systems may result in non-conformance with the standard.

2. Referenced Documents

2.1 ASTM Standards:²

[A27/A27M Specification for Steel Castings, Carbon, for General Application](#)

[A128/A128M Specification for Steel Castings, Austenitic Manganese](#)

¹ This specification is under the jurisdiction of ASTM Committee A01 on Steel, Stainless Steel and Related Alloys and is the direct responsibility of Subcommittee A01.18 on Castings.

Current edition approved Nov. 1, 2012; May 1, 2013. Published November 2012; June 2013. Originally approved in 1980. Last previous edition approved in 2012 as A781/A781M – 12a; A781/A781M – 12b. DOI: 10.1520/A0781-A0781M-12B-10.1520/A0781-A0781M-13.

² For referenced ASTM standards, visit the ASTM website, www.astm.org, or contact ASTM Customer Service at service@astm.org. For *Annual Book of ASTM Standards* volume information, refer to the standard's Document Summary page on the ASTM website.

*A Summary of Changes section appears at the end of this standard



- A148/A148M Specification for Steel Castings, High Strength, for Structural Purposes
- A297/A297M Specification for Steel Castings, Iron-Chromium and Iron-Chromium-Nickel, Heat Resistant, for General Application
- A370 Test Methods and Definitions for Mechanical Testing of Steel Products
- A380 Practice for Cleaning, Descaling, and Passivation of Stainless Steel Parts, Equipment, and Systems
- A447/A447M Specification for Steel Castings, Chromium-Nickel-Iron Alloy (25-12 Class), for High-Temperature Service
- A488/A488M Practice for Steel Castings, Welding, Qualifications of Procedures and Personnel
- A494/A494M Specification for Castings, Nickel and Nickel Alloy
- A560/A560M Specification for Castings, Chromium-Nickel Alloy
- A609/A609M Practice for Castings, Carbon, Low-Alloy, and Martensitic Stainless Steel, Ultrasonic Examination Thereof
- A743/A743M Specification for Castings, Iron-Chromium, Iron-Chromium-Nickel, Corrosion Resistant, for General Application
- A744/A744M Specification for Castings, Iron-Chromium-Nickel, Corrosion Resistant, for Severe Service
- A747/A747M Specification for Steel Castings, Stainless, Precipitation Hardening
- A751 Test Methods, Practices, and Terminology for Chemical Analysis of Steel Products
- A800/A800M Practice for Steel Casting, Austenitic Alloy, Estimating Ferrite Content Thereof
- A802/A802M Practice for Steel Castings, Surface Acceptance Standards, Visual Examination
- A890/A890M Specification for Castings, Iron-Chromium-Nickel-Molybdenum Corrosion-Resistant, Duplex (Austenitic/Ferritic) for General Application
- A915/A915M Specification for Steel Castings, Carbon, and Alloy, Chemical Requirements Similar to Standard Wrought Grades
- A941 Terminology Relating to Steel, Stainless Steel, Related Alloys, and Ferroalloys
- A958 Specification for Steel Castings, Carbon and Alloy, with Tensile Requirements, Chemical Requirements Similar to Standard Wrought Grades
- A967 Specification for Chemical Passivation Treatments for Stainless Steel Parts
- A991/A991M Test Method for Conducting Temperature Uniformity Surveys of Furnaces Used to Heat Treat Steel Products
- A1002 Specification for Castings, Nickel-Aluminum Ordered Alloy
- A1058 Test Methods for Mechanical Testing of Steel Products—Metric
- A1080 Practice for Hot Isostatic Pressing of Steel, Stainless Steel, and Related Alloy Castings
- E94 Guide for Radiographic Examination
- E125 Reference Photographs for Magnetic Particle Indications on Ferrous Castings
- E165 Practice for Liquid Penetrant Examination for General Industry
- E186 Reference Radiographs for Heavy-Walled (2 to 4½-in. (50.8 to 114-mm)) Steel Castings
- E280 Reference Radiographs for Heavy-Walled (4½ to 12-in. (114 to 305-mm)) Steel Castings
- E340 Test Method for Macroetching Metals and Alloys
- E353 Test Methods for Chemical Analysis of Stainless, Heat-Resisting, Maraging, and Other Similar Chromium-Nickel-Iron Alloys
- E354 Test Methods for Chemical Analysis of High-Temperature, Electrical, Magnetic, and Other Similar Iron, Nickel, and Cobalt Alloys
- E446 Reference Radiographs for Steel Castings Up to 2 in. (50.8 mm) in Thickness
- E709 Guide for Magnetic Particle Testing

3. Terminology

3.1 Definitions:

3.1.1 The definitions in Test Methods and Definitions A370, Test Methods, Practices, and Terminology A751, Terminology A941, and Test Methods for Mechanical Testing of Steel Products – Metric A1058 are applicable to this specification and those listed in 1.1.

3.1.2 *test coupon, n*—the part from which the test specimen will be extracted.

3.1.3 *test specimen, n*—the part that will be acted upon in a test.

4. Materials and Manufacture

4.1 *Melting Process*—The steel shall be made by open-hearth or electric furnace process with or without separate refining, such as argon-oxygen-decarburization (AOD), unless otherwise specified in the individual specification.

4.2 Heat Treatment:

4.2.1 Castings shall be heat treated in the working zone of a furnace that has been surveyed in accordance with Test Method A991/A991M.

4.2.2 When castings are heat treated at temperatures above 2000°F [1100°C], then the working zone shall have been established by a survey performed at not more than 25°F [15°C] below nor more than 200°F [110°C] above the minimum heat treatment temperature specified for the grade. If a minimum heat treatment temperature is not specified for the grade, then the survey temperature shall be not more than 50°F [30°C] below nor more than 175°F [100°C] above the furnace set point used.



TABLE 1 Product Analysis Tolerances—Carbon and Low Alloy Steels

Element	Range, % ^A	Tolerances ^{B, C} Over Maximum or Under Minimum Limit, %
C	up to 0.65	$0.03 \times \% C_L + 0.02$
	above 0.65	0.04
Mn	up to 1	$0.08 \times \% Mn_L + 0.01$
	above 1	0.09
Si	up to 0.60	$0.22 \times \% Si_L - 0.01$
	above 0.60	0.15
P	all	$0.13 \times \% P_L + 0.005$
S	all	$0.36 \times \% S_L + 0.001$
Ni	up to 2	$0.10 \times \% Ni_L + 0.03$
	above 2	0.25
Cr	up to 2	$0.07 \times \% Cr_L + 0.04$
	above 2	0.18
Mo	up to 0.6	$0.04 \times \% Mo_L + 0.03$
	above 0.6	0.06
V	up to 0.25	$0.23 \times \% V_L + 0.004$
	above 0.25	0.06
W	up to 0.10	$0.08 \times \% W_L + 0.02$
	above 0.10	0.02
Cu	up to 0.15	$0.18 \times \% Cu_L + 0.02$
	above 0.15	0.05
Al	up to 0.10	$0.08 \times \% Al_L + 0.02$
	above 0.10	0.03

^A The range denotes the composition limits up to which tolerances are computed by the equation, and above which the tolerances are given by a constant.

^B The subscript_L for the elements in each equation indicates that the limits of the element specified by the applicable specification are to be inserted into the equation to calculate the tolerance for the upper limit and the lower limit (if applicable), respectively. Examples of computing tolerances are presented in footnote C.

^C To illustrate the computation of the tolerance, consider the manganese maximum of 0.70 for a 0.30 carbon grade 65-35 in Specification A27/A27M. The maximum permissible deviation is $(0.08 \times 0.70 + 0.01) = 0.066$. Therefore, the highest acceptable product analysis is 0.766. Similarly, for a 0.20 carbon grade 70-40 in Specification A27/A27M, the maximum manganese content is 1.40; thus, the highest acceptable product analysis is $(1.40 + 0.09) = 1.49$.

ASTM A781/A781M-13

4.2.3 The maximum variation in measured temperature as determined by the difference between the highest temperature and the lowest temperature shall be as agreed between the purchaser and producer except that during production heat treatment, no portion of the furnace shall be below the minimum specified temperature nor above the maximum specified temperature for the grade being processed.

5. Chemical Composition

5.1 *Chemical Analysis*—Chemical analysis of materials covered by this specification shall be in accordance with Test Methods, Practices, and Terminology A751.

5.2 *Heat Analysis*—An analysis of each heat shall be made by the manufacturer to determine the percentages of the elements specified in the individual specification for the grade being poured. The analysis shall be made from a test sample preferably taken during the pouring of the heat. When drillings are used, they shall be taken not less than ¼ in. [6.4 mm] beneath the surface. The chemical composition thus determined shall conform to the requirements in the individual specification for the grade being poured.

5.3 *Product Analysis*—A product analysis may be made by the purchaser from material representing each heat, lot, or casting. The analysis shall be made on representative material. Samples for carbon analysis shall be taken no closer than ¼ in. [6 mm] to a cast surface, except that castings too thin for this shall be analyzed on representative material. The chemical composition thus determined shall meet the requirements specified in the applicable specification for the grade involved, or shall be subject to rejection by the purchaser, except that the chemical composition determined for carbon and low alloy steel and stainless steel castings may vary from the specified limits by the amounts shown in Tables 1 and 2 respectively. The product analysis tolerances of Tables 1 and 2 are not applicable as acceptance criteria for heat analysis by the casting manufacturer. When comparing product and heat analysis for other than carbon and low alloy steels and stainless steels, the reproducibility Data R₂, in Test Methods E353 or E354, as applicable, shall be taken into consideration.

5.4 *Unspecified Elements*—When chemical analysis for elements not specified for the grade ordered is desired, Supplementary Requirement S13 may be specified.



TABLE 2 Product Analysis Tolerances—Stainless Steels

Elements	Limit or Maximum of Specified Range, %	Tolerance Over the Maximum Limit or Under the Minimum Limit	Elements	Limit or Maximum of Specified Range, %	Tolerance Over the Maximum Limit or Under the Minimum Limit		
Carbon	to 0.010, incl	0.002	Titanium	to 1.00, incl	0.05		
	over 0.010 to 0.030, incl	0.005		over 1.00 to 3.00, incl	0.07		
	over 0.030 to 0.20, incl	0.01	Cobalt	over 0.05 to 0.50, incl	0.01 ^A		
	over 0.20 to 0.60, incl	0.02		over 0.50 to 2.00, incl	0.02		
	over 0.60 to 1.20, incl	0.03		over 2.00 to 5.00, incl	0.05		
Manganese	to 1.00, incl	0.03	Columbium plus tantalum	to 1.50, incl	0.05		
	over 1.00 to 3.00, incl	0.04		Tantalum	to 0.10, incl	0.02	
	over 3.00 to 6.00, incl	0.05			Copper	to 0.50, incl	0.03
	over 6.00 to 10.00, incl	0.06				over 0.50 to 1.00, incl	0.05
	over 10.00 to 15.00, incl	0.10	over 1.00 to 3.00, incl	0.10			
over 15.00 to 20.00, incl	0.15	over 3.00 to 5.00, incl	0.15				
Phosphorus	to 0.040, incl	0.005	over 5.00 to 10.00, incl	0.20			
	over 0.040 to 0.20, incl	0.010	Aluminum	to 0.15, incl	-0.005, +0.01		
Sulfur	to 0.040, incl	0.005		over 0.15 to 0.50, incl	0.05		
	over 0.040 to 0.20, incl	0.010		over 0.50 to 2.00, incl	0.10		
	over 0.20 to 0.50, incl	0.020	Nitrogen	to 0.02, incl	0.005		
Silicon	to 1.00, incl	0.05		over 0.02 to 0.19, incl	0.01		
	over 1.00 to 3.00, incl	0.10		over 0.19 to 0.25, incl	0.02		
	over 3.00 to 6.00, incl	0.15		over 0.25 to 0.35, incl	0.03		
Chromium	over 4.00 to 10.00, incl	0.10		over 0.35 to 0.45, incl	0.04		
	over 10.00 to 15.00, incl	0.15	over 0.45 to 0.55, incl	0.05			
	over 15.00 to 20.00, incl	0.20	Tungsten	to 1.00, incl	0.03		
	over 20.00 to 30.00, incl	0.25		over 1.00 to 2.00, incl	0.05		
Nickel	to 1.00, incl	0.03	Vanadium	to 0.50, incl	0.03		
	over 1.00 to 5.00, incl	0.07		over 0.50 to 1.50, incl	0.05		
	over 5.00 to 10.00, incl	0.10	Selenium	all	0.03		
	over 10.00 to 20.00, incl	0.15					
	over 20.00 to 30.00, incl	0.20					
Molybdenum	over 0.20 to 0.60, incl	0.03					
	over 0.60 to 2.00, incl	0.05					
	over 2.00 to 8.00, incl	0.10					

^A Product analysis limits for cobalt under 0.05 % have not been established, and the manufacturer should be consulted for those limits.

<https://standards.iteh.ai/catalog/standards/sist/b37bed44-36b7-40a7-8483-6c13d840e81f/astm-a781-a781m-13>

5.5 Grade Substitution—Grade substitution is not permitted. Grade substitution occurs when the material being supplied contains one or more elements that are not specified for the supplied material such that the material conforms to the requirements of a different grade.

6. Mechanical Test Requirements

6.1 The individual product specifications vary as to whether mechanical tests are required; for this reason, and to determine specific test requirements, the individual product specification should be reviewed.

6.2 Unless otherwise specified by the purchaser, when mechanical properties are required by the product specification, test coupons may be cast integrally with the castings, or as separate blocks, in accordance with Fig. 1, Fig. 2, or Fig. 3, except when Supplementary Requirement S15 is specified. The test coupon in Fig. 3 shall be employed only for austenitic alloy castings with cross sections less than 2½ in. [65 mm].³

6.3 Choice of testing track from the options listed in Test Methods A1058 when material is ordered to an M suffix (SI units) product standard, should be identified by the purchaser in the ordering information. If the choice of test track is not specified in the order, then the default ASTM track shall be used as noted in Test Methods A1058.

³ Information on the relationship of mechanical properties determined on test coupons obtained as specified in 6.2 with those obtained from the casting may be found in *The Steel Casting Handbook*, Fifth Edition, Steel Founders' Society of America, pp. 15-35 through 15-43, 1980. Information on the relationship of mechanical properties determined on test coupons obtained as specified in 6.2 with those obtained from the casting may be found in *The Steel Casting Handbook*, Fifth Edition, Steel Founders' Society of America, pp. 15-35 through 15-43, 1980.

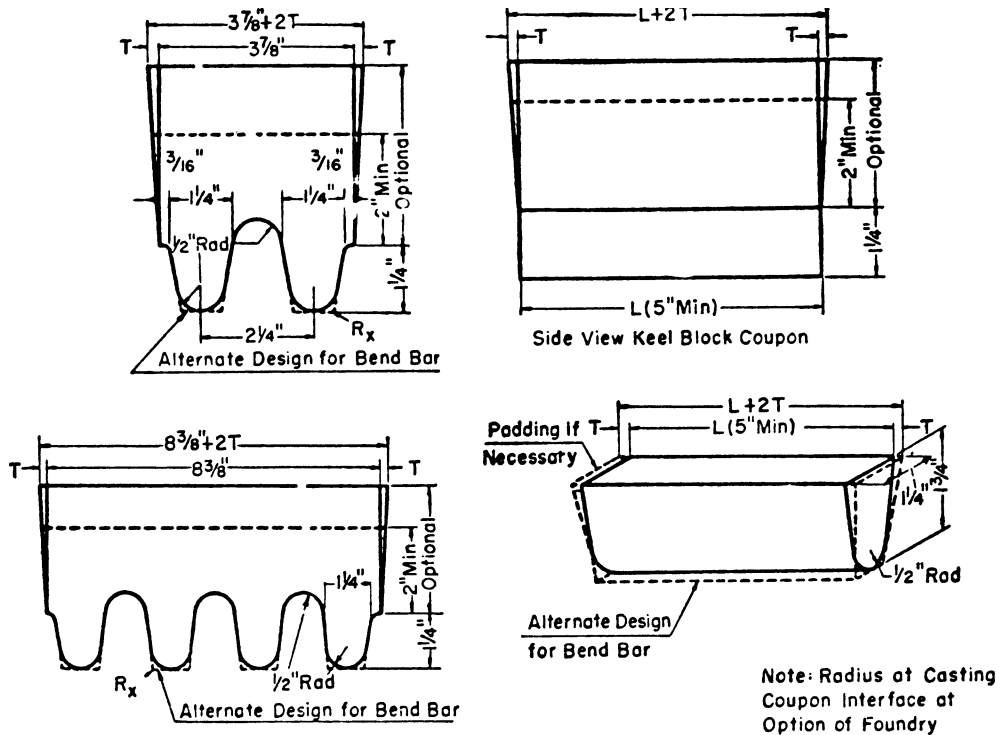

in.	3/16	1/2	1/4	1 3/4	Metric Equivalents				2	2 1/4	3/8	5	8 3/8
[mm]	[4.8]	[13]	[32]	[45]	[51]	[57]	[98]	[127]	[213]				

Leg Design [125 mm]		Riser Design	
1. L (length)	A 5 in. [125 mm] minimum length will be used. This length may be increased at the option of the foundry to accommodate additional test specimens (see Note 1).	1. L (length)	The length of the riser at the base will be the same as the top length of the leg. The length of the riser at the top therefore depends on the amount of taper added to the riser.
2. End Taper	Use of and size of end taper is at the option of the foundry.	2. Width	The width of the riser at the base of a multiple-leg coupon shall be $n(2\frac{1}{4}) [57 \text{ mm}] - \frac{5}{8} [16 \text{ mm}]$ where n equals the number of legs attached to the coupon. The width of the riser at the top is therefore dependent on the amount of taper added to the riser.
3. Height	1 1/4 in. [32 mm]	3. T (riser taper) Height	Use of and size is at the option of the foundry. The minimum height of the riser shall be 2 in. [51 mm]. The maximum height is at the option of the foundry for the following reasons: (a) many risers are cast open, (b) different compositions may require variation in risering for soundness, and (c) different pouring temperatures may require variation in risering for soundness.
4. Width (at top)	1 1/4 [32 mm] (see Note 1).		
5. Radius (at bottom)	1/2 in. [13 mm], max		
6. Spacing between legs	A 1/2-in. [13-mm] radius will be used between the legs.		
7. Location of test specimens	The tensile, bend, and impact specimens will be taken from the lower portion of the leg (see Note 2).		
8. Number of legs	The number of legs is at the option of the foundry providing they are equi-spaced according to Item 6.		
9. R_s	Radius from 0 to approximately 1/16 in. [2 mm].		

NOTE 1—*Test Coupons for Large and Heavy Steel Castings*: The test coupons in Fig. 1 are to be used for large and heavy steel castings. However, at the option of the foundry the cross-sectional area and length of the standard coupon may be increased as desired.

NOTE 2—*Bend Specimen*: If a bend specimen is required, an alternate design (as shown by dotted lines in Fig. 1) is indicated.

FIG. 1 Test Coupons for Castings with Details of Design

7. Workmanship, Finish, and Appearance

7.1 All castings shall be made in a workmanlike manner and shall conform to the dimensions on drawings furnished by the purchaser before manufacture is started. If the pattern is supplied by the purchaser, the dimensions of the casting shall be as predicated by the pattern.

8. Quality

8.1 The surface of the casting shall be free of adhering sand, scale, cracks, and hot tears as determined by visual examination. Other surface discontinuities shall meet the visual acceptance standards specified in the order. Practice A802/A802M or other

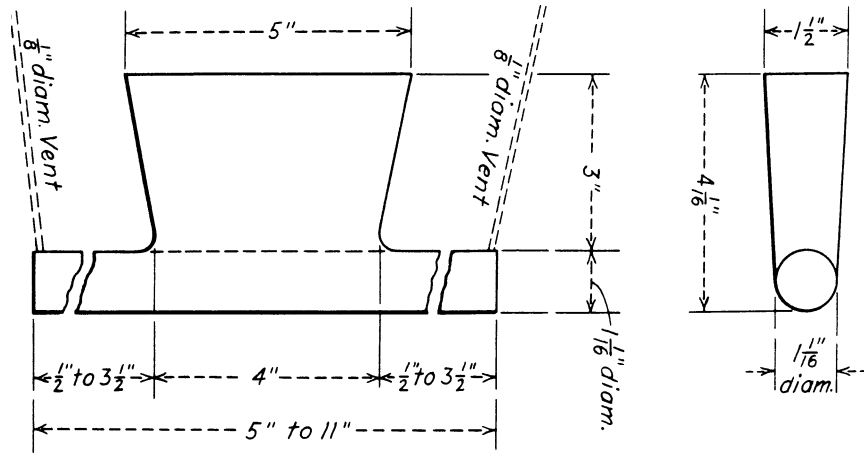

Metric Equivalents

in.	[mm]	in.	[mm]
1/8	[3.2]	3 1/2	[88.9]
1/2	[12.7]	4	[101.6]
1 1/16	[27.0]	4 1/16	[103.2]
1 1/2	[38.1]	5	[127.0]
3	[76.2]	11	[279.4]

NOTE 1—Pour through head; cover molten head with powdered charcoal, coke dust, and so forth, immediately after pouring, in order to keep head fluid as long as possible.

FIG. 2 Test Coupon for Tension Test

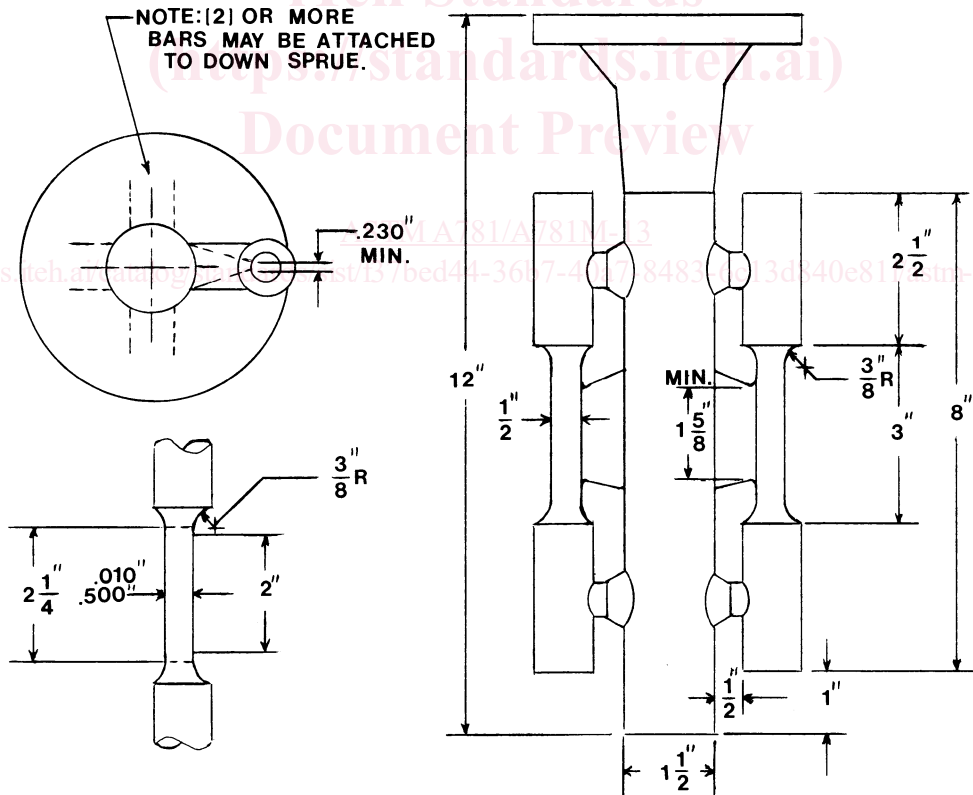

NOTE 1—Coupons produced in this manner are suitable for austenitic alloys only. The mold may be preheated for pouring to produce a sound coupon.

FIG. 3 Cast-To-Shape Test Coupon for Tension Specimen

visual standards may be used to define acceptable surface discontinuities and finish. Unacceptable visual surface discontinuities shall be removed and their removal verified by visual examination of the resultant cavities.