



Standard Test Method for Surface Flammability of Materials Using a Radiant Heat Energy Source¹

This standard is issued under the fixed designation E162; the number immediately following the designation indicates the year of original adoption or, in the case of revision, the year of last revision. A number in parentheses indicates the year of last reapproval. A superscript epsilon (ϵ) indicates an editorial change since the last revision or reapproval.

This standard has been approved for use by agencies of the Department of Defense.

1. Scope

1.1 This fire-test-response standard describes the measurement of surface flammability of materials. It is not intended for use as a basis of ratings for building code purposes (see [Appendix XI](#)).

1.2 The values stated in inch-pound units are to be regarded as standard. The values given in parentheses are mathematical conversions to SI units that are provided for information only and are not considered standard.

1.3 This standard measures and describes the response of materials, products, or assemblies to heat and flame under controlled conditions, but does not by itself incorporate all factors required for fire hazard or fire risk assessment of the materials, products, or assemblies under actual fire conditions.

1.4 *This standard does not purport to address all of the safety concerns, if any, associated with its use. It is the responsibility of the user of this standard to establish appropriate safety and health practices and determine the applicability of regulatory limitations prior to use.*

1.5 Fire testing of products and materials is inherently hazardous, and adequate safeguards for personnel and property shall be employed in conducting these tests. This test method may involve hazardous materials, operations, and equipment. Specific information about hazard is given in [Section 7](#).

NOTE 1—There is no similar or equivalent ISO standard.

2. Referenced Documents

2.1 ASTM Standards:²

[D3675 Test Method for Surface Flammability of Flexible Cellular Materials Using a Radiant Heat Energy Source](#)

[E84 Test Method for Surface Burning Characteristics of Building Materials](#)

[E176 Terminology of Fire Standards](#)

[E1546 Guide for Development of Fire-Hazard-Assessment Standards](#)

2.2 ISO Standards³

[ISO 13943 Fire Safety—Vocabulary](#)

3. Terminology

3.1 *Definitions*—For definitions of terms used in this test method, refer to the terminology contained in Terminology [E176](#) and ISO 13943. In case of conflict, the definitions given in Terminology [E176](#) shall prevail.

3.2 *Definitions of Terms Specific to This Standard:*

3.2.1 *flashing, n*—flame fronts of 3 seconds or less in duration.

¹ This test method is under the jurisdiction of ASTM Committee [E05](#) on Fire Standards and is the direct responsibility of Subcommittee [E05.22](#) on Surface Burning. Current edition approved ~~Jan. 15, 2012~~ May 15, 2013. Published ~~February 2012~~ June 2013. Originally approved in 1960. Last previous edition approved in 2012 as ~~E162 – 12~~ E162 – 12a. DOI: ~~10.1520/E0162-12A~~ 10.1520/E0162-13.

² For referenced ASTM standards, visit the ASTM website, www.astm.org, or contact ASTM Customer Service at service@astm.org. For *Annual Book of ASTM Standards* volume information, refer to the standard's Document Summary page on the ASTM website.

³ Available from International Organization for Standardization (ISO), 1, ch. de la Voie-Creuse, Case postale 56, CH-1211, Geneva 20, Switzerland, <http://www.iso.ch>.

3.2.1.1 *Discussion*—

All flame fronts, however temporary, are to be taken into account.

3.2.2 *radiant panel index, I_s, n* —the radiant panel index is the product of the flame spread factor, F_s , and the heat evolution factor, Q .

4. Summary of Test Method

4.1 This test method of measuring surface flammability of materials employs a radiant heat source consisting of a 12 by 18-in. (305 by 457-mm) panel, in front of which an inclined 6 by 18-in. (152 by 457 mm) specimen of the material is placed. The orientation of the specimen is such that ignition is forced near its upper edge and the flame front progresses downward.

4.2 A factor derived from the rate of progress of the flame front and another derived from the rate of heat liberated by the material under test are combined to provide a radiant panel index.

5. Significance and Use

5.1 This test method provides a laboratory test procedure for measuring and comparing the surface flammability of materials when exposed to a prescribed level of radiant heat energy. It is intended for use in measurements of the surface flammability of materials exposed to fire. The test is conducted using small specimens that are representative, to the extent possible, of the material or assembly being evaluated. (Example: in terms of their thickness, layering, and any potential substrate.)

5.2 The rate at which flames will travel along surfaces depends upon the physical and thermal properties of the material, product or assembly under test, the specimen mounting method and orientation, the type and level of fire or heat exposure, the availability of air, and properties of the surrounding enclosure.⁴

5.3 In this procedure, the specimens are subjected to one or more specific sets of laboratory fire test conditions. If different test conditions are substituted or the end-use conditions are changed, it is not always possible by or from this test to predict changes in the fire-test-response characteristics measured. Therefore, the results are valid only for the fire test exposure conditions described in this procedure.

5.4 If the test results obtained by this test method are to be considered as part of an overall assessment of fire hazard in a building or structure, then the example criteria, concepts and procedures incorporated into Guide E1546 shall be taken into consideration.

6. Apparatus

6.1 The apparatus shall be as shown in Fig. 1 and include the following:

6.1.1 *Radiant Panel with Air and Gas Supply*—The radiant panel shall consist of a porous refractory material vertically mounted in a cast iron frame, exposing a radiating surface of 12 by 18 in. (305 by 457 mm) and shall be capable of operating at temperatures up to 1500°F (815°C). The panel shall be equipped (see Fig. 1) with a venturi-type aspirator for mixing gas and air at approximately atmospheric pressure; a centrifugal blower, or equivalent, capable of providing 1200 ft³/h (9.4 L/s) air at a pressure of 2.8 in. of water (700 Pa); an air filter to prevent dust from obstructing the panel pores; a pressure regulator and a control and shut-off valve for the gas supply.

6.1.2 *Specimen Holder*—The specimen holder shall conform in shape and dimension to Fig. 2 and be constructed from heat-resistant chromium steel. Observation marks shall be filed on the surface of the specimen holder to correspond with 3-in. (76-mm) interval lines on the specimen.

6.1.3 *Framework for Support of the Specimen Holder*—The framework shall have two transverse rods of stainless steel, each 0.50 ± 0.13 in. (12.7 ± 3.3 mm) in diameter, with a stop to center the specimen holder directly in front of the radiant panel. The support and bracing members shall be constructed from metal stock. Since the angle of the specimen and its position with respect to the panel are critical, the framework dimensions specifying these conditions shall be within 0.125 in. (3.2 mm) of the values given in Fig. 1.

6.1.4 *Pilot Burner*—The pilot burner shall be a length of stainless steel tubing approximately 8 to 9 in. (203 to 229 mm) long with nominally 0.125 in. (3.2 mm) inside diameter by nominally 0.19 in. (4.8 mm) outside diameter. As an option, to prolong the service life of the pilot burner, the part of the burner that is exposed to radiant energy can be protected with a porcelain tube nominally 0.20 in. (5.2 mm) inside diameter by nominally 0.28 in. (7.14 mm) outside diameter. The burner shall be mounted horizontally and at a slight angle to the intersection of the horizontal plane of the burner with the plane of the specimen. The burner shall also be capable of being moved out of position when not in use. The pilot shall provide a 2 to 3 in. (51 to 76-mm) flame of acetylene gas premixed with air in an aspirating type fitting. The position of the burner tip shall be such that the pilot flame shall contact or shall be within 0.5 in. (12.7 mm) of contacting the upper central surface of the specimen.

6.1.5 *Stack*—The stack shall be made from nominally 0.040 in. (1.0 mm) sheet steel with shape and dimensions as shown in Fig. 1. The position of the stack with respect to the specimen and radiant heat panel shall also comply with the requirements of Fig. 1.

⁴ Robertson, A. F., "Surface Flammability Measurements by the Radiant Panel Method," *Symposium on Fire Test Methods, ASTM STP 344*, ASTM, 1962, pp. 33–46.
Robertson, A. F., Gross, D., and Loftus, J., "A Method for Measuring Surface Flammability of Materials Using a Radiant Energy Source," *Proceedings, ASTM*, Vol 56, 1956, pp. 1437–1453.

Gross, D. and Loftus, J. J., "Surface Flame Propagation on Cellulosic Materials Exposed to Thermal Radiation," *Journal of Research, NBS*, Vol 67C, 1963, pp. 251–258.
Magee, R. S. and McAlevy III, R. F., "The Mechanism of Flame Spread," *Journal of Fire and Flammability*, Vol 2, 1971, pp. 271–297.

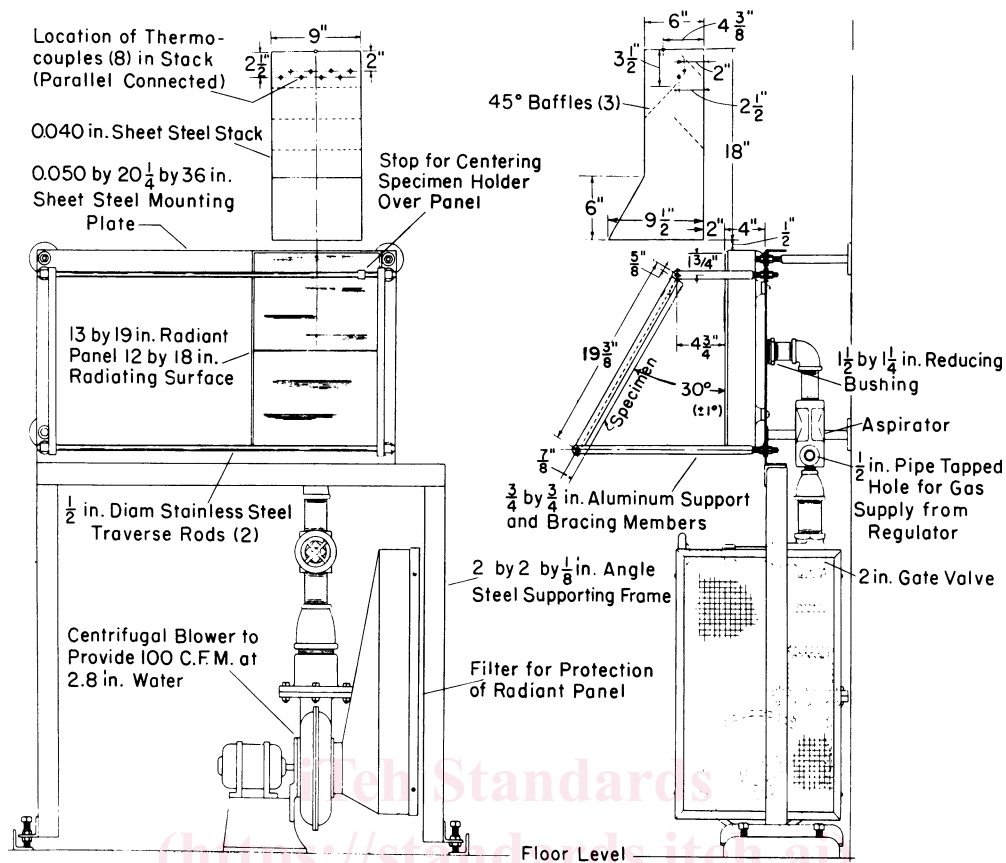

Metric Equivalents

in.	mm	in.	mm
0.040	1.0	6	152
1/2	13	9 1/2	241
5/8	16	18	457
7/8	22	19 3/8	492
1 1/4	44	3/4 by 3/4	19 by 19
2	51	1 1/2 by 1 1/4	38 by 32
2 1/2	64	12 by 18	305 by 457
2.8	71	13 by 19	330 by 483
4	102	2 by 2 by 1/8	51 by 51 by 3.2
4 3/8	111	0.050 by 20 1/4 by 36	1.3 by 514 by 914
4 3/4	121		

100 ft³/min = 47.21 L/s

FIG. 1 Details of Construction of Test Equipment

6.1.6 *Thermocouples*—Eight thermocouples of equal resistance and connected in parallel shall be mounted in the stack and supported with porcelain insulators as indicated in Fig. 1 and Fig. 3. The thermocouples shall be Chromel-Alumel Type K, shielded against high heat with insulation resisting up to 2190° F (1200° C), and with wire gauges in the range of 0.014 – 0.020 in. (0.36 – 0.51 mm; 30 AWG–24 AWG) diameter. The mean stack thermocouple temperature rise for unit heat input rate of the calibration burner shall be determined periodically for the specific test apparatus, using the procedure in A1.2.

6.1.7 *Data Collection System*—For collecting test data, use one of the following:

6.1.7.1 *Automatic Potentiometer Recorder*—An automatic potentiometer recorder in the range from 100 to 1000° F (38 to 538° C) shall be installed to record the temperature variation of the stack thermocouples as described in 6.1.6.

6.1.7.2 *Computer Data Collection System*—The data acquisition system shall have the capability to record the temperature output from the thermopile. The data acquisition system shall have an accuracy of 0.01% of the maximum temperature to be measured.

6.1.7.3 *Whichever system is used, it shall be capable of recording, or printing, data at least every 5 s for a minimum of 1 h. For cases where preliminary tests indicate rapid flame spread, a system shall be used capable of acquiring data fast enough to ensure adequate results (see 12.5).*

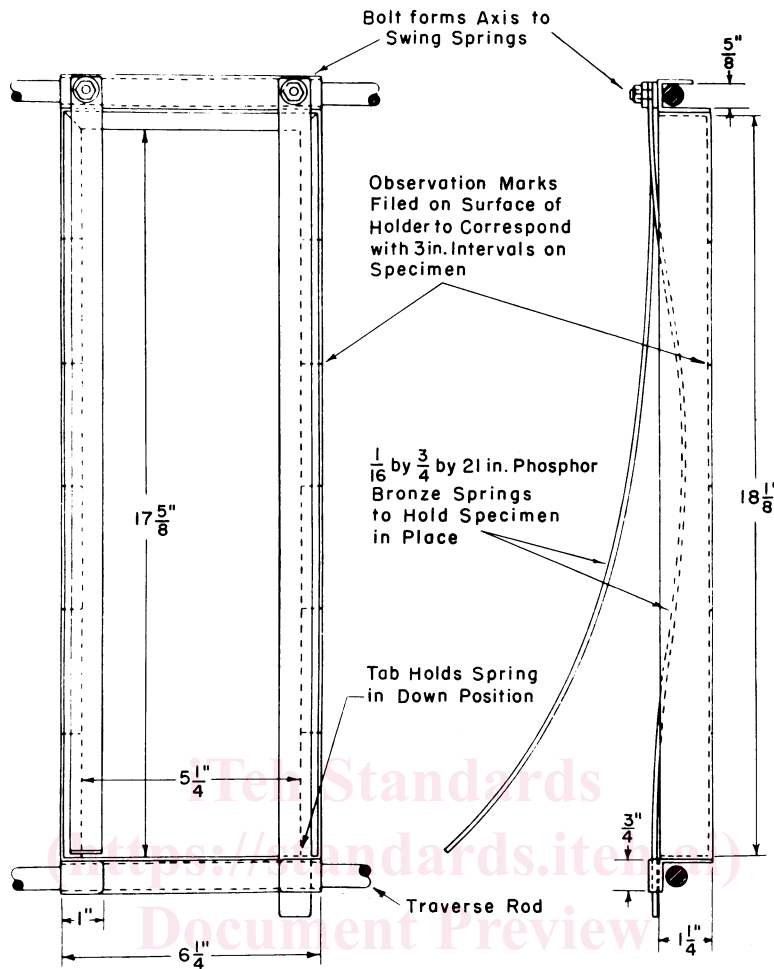

Metric Equivalents

in.	mm	in.	mm
$\frac{3}{4}$	19	$6\frac{1}{4}$	159
1	25	$17\frac{5}{8}$	448
$1\frac{1}{4}$	32	$18\frac{1}{8}$	460
3	76	$\frac{1}{16}$ by $\frac{3}{4}$ by 21	1.6 by 19 by 533
$5\frac{1}{4}$	133		

FIG. 2 Specimen Holder

6.1.8 *Hood*—A hood with exhaust blower placed over the stack is required. Before igniting the panel, but with the exhaust hood operating, the air flow rate through the stack needs to produce a velocity of 80 to 100 ft/min (24.4 to 30.5 m/min). Measurements are to be made either with a hot wire anemometer after at least 30 s of insertion of the probe into the center of the stack at a distance of 6 in. (152 mm) down from the top of the stack opening, or with a bi-directional probe or similar device at the top of the stack opening. The hot wire anemometer, bi-directional probe, or similar device, shall have an accuracy of ± 0.1 m/s. The velocity through the stack is not critical for flame-spread measurements provided a stack thermocouple temperature calibration is performed (see 6.1.6 and A1.2) for the established test conditions. The hood surfaces shall clear the top and sides of the stack by a minimum of 10 in. (254 mm) and 7.5 in. (191 mm) respectively.

6.1.8.1 In order to facilitate the insertion of the hot wire anemometer probe, a hole of adequate diameter to allow its insertion shall be pre-drilled through the hood, in the center of either of the 152-mm (6-in.) wide surfaces, so as to prevent contact of the probe with the internal baffles. The hole is intended to be used for insertion of the probe and shall be plugged after the air flow rate has been established, and before testing.

NOTE 2—Testing has shown that the air flow rate through the stack, if measured during operating conditions using a bi-directional probe or similar device, produces a velocity of approximately 250 ft/min.

6.1.9 *Radiation Pyrometer*—The radiation pyrometer for standardizing the thermal output of the panel shall be suitable for viewing a circular area 10 in. (254 mm) in diameter at a range of about 4 ft (1.2 m). It shall be calibrated over the operating black body temperature range in accordance with the procedure described in Annex A1.

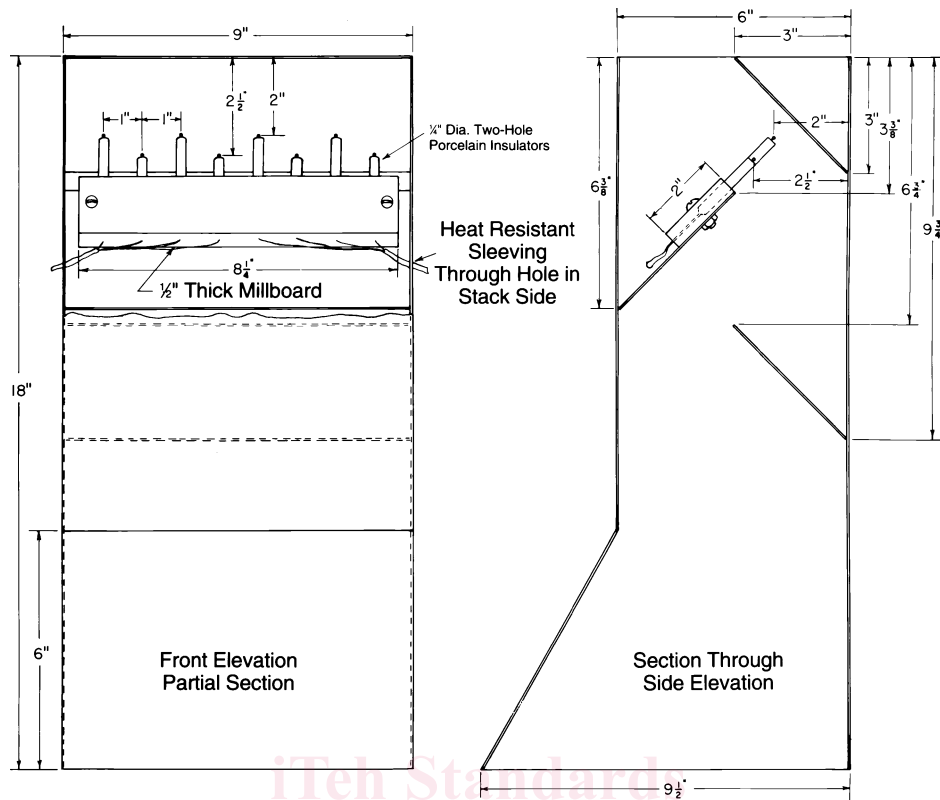

Metric Equivalents					
in.	mm	in.	mm	in.	mm
1/4	6.4	3	76	9	229
1/2	13	3 3/8	86	9 1/2	241
1	25	6	152	9 3/4	248
2	51	6 3/4	171	18	457
2 1/2	64	8 1/4	210		

FIG. 3 Thermocouple Mounting Arrangement

- 6.1.9.1 Monitor and record the millivolt output of the radiation pyrometer with the data collection systems described in 6.1.7.
- 6.1.10 *Timer*—The timer shall be calibrated to read to 0.01 min to record the time of events during the test.

7. Hazards

7.1 Safeguards shall be installed in the panel fuel supply system to guard against a gas air fuel explosion in the test chamber. Potential safeguards include, but are not limited to, one or more of the following: a gas feed cut-off activated when the air supply fails; a flame sensor directed at the panel surface that stops fuel flow when the panel flame goes out; and a heat detector mounted in contact with the radiant panel plenum that is activated when the panel temperature exceeds safe limits. Manual reset is a requirement of any safeguard system used.

7.2 The exhaust system must be so designed and operated that the laboratory environment is protected from smoke and gas. The operator shall be instructed on ways to minimize exposure to combustion products by following sound safety and industrial hygiene practices. For example, ensure that the exhaust system is working properly and wear appropriate clothing including gloves, safety glasses, and breathing apparatus (when hazardous fumes are expected).

7.3 During this test, very high heat fluxes and high temperatures are generated that are capable of igniting some clothing following even brief exposures. Precautions shall be taken to avoid ignitions of this type.

8. Test Specimens

8.1 The test specimen shall be 6 by 18 in. (152 by 457 mm) by the sheet thickness, where this is less than 1 in. (25.4 mm). Materials supplied at a thickness greater than 1 in. (25.4 mm) shall be cut to 1 in. (25.4 mm) for testing. At the request of the sponsor, it is possible to test materials greater than 1 in. (25.4 mm) thickness by using an oversized specimen holder.

8.2 Materials intended to be applied to a substrate shall be tested on that substrate.

8.3 For comparison tests, or where the intended application of a finish material is not specified, the finish material shall be prepared for test in accordance with 8.4-8.6.

8.4 Opaque sheet materials up to 1/16-in. (1.6-mm) thickness, and liquid films such as paints, etc. intended for application to combustible base materials, shall be applied to 1/4-in. (6.4-mm) thick tempered hardboard using recommended application procedures. The hardboard shall have a mean flame-spread index of 130 to 160 based upon a minimum of four tests performed in accordance with this method.

8.5 Liquid films and other materials for application to a noncombustible base shall be applied to the smooth surface of 1/4-in. (6.4-mm) thick inorganic reinforced cement board, using specified spreading rate requirements, or, in the absence of requirements, a minimum-coating thickness of 0.030 in. (0.76 mm).

NOTE 3—Wherever inorganic reinforced cement board is specified, the material shall be nominal 1/4 in. (6 mm) thick, high density (110 ± 5 lb/ft³ (1762 ± 80 kg/m³)) and uncoated.

8.6 A backing of aluminum foil 0.002 in. (0.05 mm) thick, with the bright side against the specimen shall be used.

8.7 Materials, including fabrics, not applied to a base but supported at one or more edges shall be mounted on a special backing of 1/2-in. (13-mm) thick millboard of which the surface opposite the test specimen is covered with a sheet of highly reflective aluminum foil 0.002 in. thick, with the bright side against the specimen. Millboard spacers 1/2 by 1/2 in. (12.7 by 12.7 mm) shall be used at the perimeter of the foil-covered face of the backing to separate the test material from the foil. Flexible materials shall be cut to 10 by 22-in. (255 by 560-mm) size, folded around the frame and fastened to the rear surface of the millboard with tension sufficient only to remove slack.

NOTE 4—Wherever millboard is specified, the material shall be cement bound of commercial quality nominal 1/2-in. (13-mm) thick and density of 60 ± 5 lb/ft³ (960 ± 80 kg/m³).

8.7.1 For cellular elastomers and cellular plastics, whether flexible or not, the back and sides of the test specimen shall be wrapped with aluminum foil 0.002 in. (0.05 mm) thick, with the bright side against the specimen. High density inorganic reinforced cement board, 0.25 in. (6.4 mm) in thickness, shall be used as backing. The test specimen shall be retained in the specimen holder by a 6 by 18-in. (152 by 457-mm) sheet of nominally 1-in. (25.4-mm) hexagonal steel wire mesh, 20 AWG, placed against the exposed face of the specimen. Molded skin or treated surfaces shall face the exposure.

8.7.2 For testing of flexible cellular materials see also Test Method D3675, which uses a different pilot burner.

8.8 Finish materials, including sheet laminates, tiles, fabrics, and others applied to a base material with adhesive as well as laminated materials not attached to a base shall be tested for possible increased flame spread or associated hazard due to delamination, cracking, peeling, or other separation of the finish material. An increase in flame spread may be caused by flaming on the reverse face of the test material, or by ignition of the adhesive or base material. Determination of the existence of such effects shall be made as follows:

8.8.1 One or more specimens of the sample material shall be tested as received in the manner prescribed herein for the flame spread determination of ordinary materials.

8.8.2 Materials that tend to delaminate or in any way separate from the specimen holder during the above test exposure shall be retested using one or more specimens in which the material is retained in position by a 6 by 18-in. (150 by 460-mm) sheet of 1-in. (25-mm) hexagonal wire mesh placed in the specimen holder and against the exposed face of the specimen.

8.9 If, in this initial test, any material tends to melt, soften, crack, split, or fall from the specimen holder, it shall be retested with a wire support as described in 8.8.2 and the higher of the two results shall be adopted as the flame spread index.

8.10 All specimens except those over 3/4 in. (19.0 mm) thick shall be backed with 1/2-in. (13-mm) millboard of 60 lb/ft³ (960 kg/m³) density.

9. Number of Test Specimens

9.1 Four test specimens of each sample shall be tested. If one or more tests are deemed to be invalid, additional tests shall be conducted until four valid test results have been developed (see 11.12).

10. Conditioning

10.1 Predry specimens for 24 h at 140°F (60°C) and then condition to equilibrium (constant weight) at an ambient temperature of 73 ± 5°F (23 ± 3°C) and a relative humidity of 50 ± 5 %.

11. Procedure

11.1 Remove combustion product deposits from the thermocouples by brush-cleaning or other effective method after each test.

11.2 During the conduct of the test, control extraneous drafts by closing windows and doors, stop air-circulating devices, and arrange baffles between the apparatus and any remaining sources of drafts.

11.3 At the start of each testing day, ignite the gas-air mixture passing through the radiant panel and allow the unit to heat for 0.5 h. Before each test, check the radiant output by means of the radiation pyrometer. Do this by placing the pyrometer in such