

2024-02-15

ISO/PRF 32543-1:2024

ISO-/TC-135/SC-5

Secretariat:-DIN

# Non-destructive testing— Characteristics of focal spots in industrial X-ray systems—

—

## Part 1: Pinhole camera radiographic method

*Essais non destructifs — Caractéristiques des foyers émissifs des tubes radiogènes industriels —*

*Partie 1: Méthode radiographique par sténopé*

ISO/PRF 32543-1

<https://standards.iteh.ai/catalog/standards/iso/96d25088-a4f2-4ef4-889d-68a657f77317/iso-prf-32543-1>

**PROOF**

~~Edited DIS -  
MUST BE USED  
FOR FINAL  
DRAFT~~

© ISO 2024

All rights reserved. Unless otherwise specified, or required in the context of its implementation, no part of this publication may be reproduced or utilized otherwise in any form or by any means, electronic or mechanical, including photocopying, or posting on the internet or an intranet, without prior written permission. Permission can be requested from either ISO at the address below or ISO's member body in the country of the requester.

ISO copyright office  
CP 401 • Ch. de Blandonnet 8  
CH-1214 Vernier, Geneva  
Phone: +41 22 749 01 11  
~~Email~~E-mail: [copyright@iso.org](mailto:copyright@iso.org)  
Website: [www.iso.org](http://www.iso.org)~~www.iso.org~~

Published in Switzerland

iTeh Standards  
(<https://standards.iteh.ai>)  
Document Preview

[ISO/PRF 32543-1](#)

<https://standards.iteh.ai/catalog/standards/iso/96d25088-a4f2-4ef4-889d-68a657f77317/iso-prf-32543-1>

## Contents

|  |    |
|--|----|
| Foreword .....   | v  |
| Introduction.....  | vi |
| 1 Scope .....  | 1  |
| 2 Normative references.....  | 1  |
| 3 Terms and definitions .....  | 1  |
| 4 Test equipment.....  | 2  |
| 4.1 Essential characteristics of the pinhole .....                                     | 2  |
| 4.2 Alignment and position of the pinhole camera .....                                 | 3  |
| 4.3 Position of the radiographic image detector .....                                  | 4  |
| 4.4 Requirements on the radiographic image detector.....                               | 7  |
| 4.5 Image processing equipment for digital images .....                                | 7  |
| 4.6 Loading factors .....  | 8  |
| 5 Measurement and determination of the focal spot size.....                            | 8  |
| 5.1 Measurement procedure .....  | 8  |
| 5.2 Measurement with digital technique (preferred method) .....                        | 10 |
| 5.3 Evaluation with digital technique using integrated line profiles (ILP) .....       | 10 |
| 5.4 Measurement of effective focal spot size visually using film radiographs.....      | 15 |
| 6 Classification and result of focal spot size measurement.....                        | 16 |
| Annex A (normative) Values for the classification of X-ray tube focal spot sizes ..... | 18 |
| Bibliography.....  | 20 |

ISO/PRF 32543-1

<https://standards.iteh.ai/catalog/standards/iso/96d25088-a4f2-4ef4-889d-68a657f77317/iso-prf-32543-1>

Foreword — iv

Introduction — v

1 — Scope — 1

2 — Normative references — 1

3 — Terms and definitions — 1

4 — Test equipment — 2

4.1 — Essential characteristics of the pinhole — 2

4.2 — Alignment and position of the pinhole camera — 3

4.3 — Position of the radiographic image detector — 4

4.4 — Requirements on the radiographic image detector — 5

4.5 — Image processing equipment for digital images — 6

4.6 — Loading factors — 6

5 — Measurement and determination of the focal spot size — 6

5.1 — Measurement procedure — 6

5.2 — Measurement with digital technique (preferred method) — 7

5.3 — Evaluation with digital technique using Integrated Line Profiles (ILP) — 8

|                     |  |    |
|---------------------|--|----|
| 5.4                 | Measurement of effective focal spot size visually using film radiographs | 10 |
| 6                   | Classification and result of focal spot size measurement                 | 10 |
| Annex A (normative) | Values for the classification of X-ray tube focal spot sizes             | 12 |
| Bibliography        |  | 16 |

iTeh Standards  
(<https://standards.itih.ai>)  
Document Preview

[ISO/PRF 32543-1](#)

<https://standards.itih.ai/catalog/standards/iso/96d25088-a4f2-4ef4-889d-68a657f77317/iso-prf-32543-1>

## Foreword

ISO (the International Organization for Standardization) is a worldwide federation of national standards bodies (ISO member bodies). The work of preparing International Standards is normally carried out through ISO technical committees. Each member body interested in a subject for which a technical committee has been established has the right to be represented on that committee. International organizations, governmental and non-governmental, in liaison with ISO, also take part in the work. ISO collaborates closely with the International Electrotechnical Commission (IEC) on all matters of electrotechnical standardization.

The procedures used to develop this document and those intended for its further maintenance are described in the ISO/IEC Directives, Part 1. In particular, the different approval criteria needed for the different types of ISO document should be noted (see [www.iso.org/directives](http://www.iso.org/directives))-[www.iso.org/directives](http://www.iso.org/directives)).

ISO draws attention to the possibility that the implementation of this document may involve the use of (a) patent(s). ISO takes no position concerning the evidence, validity or applicability of any claimed patent rights in respect thereof. As of the date of publication of this document, ISO had not received notice of (a) patent(s) which may be required to implement this document. However, implementers are cautioned that this may not represent the latest information, which may be obtained from the patent database available at [www.iso.org/patents](http://www.iso.org/patents)-[www.iso.org/patents](http://www.iso.org/patents). ISO shall not be held responsible for identifying any or all such patent rights.

Any trade name used in this document is information given for the convenience of users and does not constitute an endorsement.

For an explanation of the voluntary nature of standards, the meaning of ISO specific terms and expressions related to conformity assessment, as well as information about ISO's adherence to the World Trade Organization (WTO) principles in the Technical Barriers to Trade (TBT), see [www.iso.org/iso/foreword.html](http://www.iso.org/iso/foreword.html).  
[www.iso.org/iso/foreword.html](http://www.iso.org/iso/foreword.html).

This document was prepared by the European Committee for Standardization (CEN) (EN 12543-2:2021) and was adopted (without modification other than those given below) by Technical Committee(s) ISO/TC 135, *Non-destructive testing*, Subcommittee SC 5, *Radiographic testing*.  
[www.iso.org/iso/foreword.html](http://www.iso.org/iso/foreword.html)

The main changes are as follows:

- ~~—~~ verbal forms in the Scope and ~~5.15.1~~ NOTE have been modified to meet ISO content requirements;
- ~~—~~ definitions in ~~Clause 3~~ Clause 3 have been modified to remove reference to content outside ~~Clause 3~~ Clause 3;
- ~~—~~ ~~figures 5, 6~~ Figures 5, 6 and ~~77~~ have been updated;
- ~~—~~ ~~keys have been added to figures 1, 2, 3, 4, 5 and 6~~;
- ~~—~~ keys have been added to Figures 1, 2, 3, 4, 5 and 6;
- change "profile integration" to "profile averaging" when referring to the averaging of the profile lines;
- ~~—~~ minor editorial corrections.

A list of all parts in the ISO 32543 series can be found on the ISO website.

Any feedback or questions on this document should be directed to the user's national standards body. A complete listing of these bodies can be found at [www.iso.org/members.html](http://www.iso.org/members.html)-[www.iso.org/members.html](http://www.iso.org/members.html).

## Introduction

In order to cover the large range of effective focal spot sizes, different methods are described in ~~the~~ ISO 32543 series.

The pinhole method of ISO 32543-1 is intended for effective focal spot sizes above 0,1 mm and mainly used for sealed standard and mini focus tubes. ASTM E1165 describes the same pinhole procedure.

The edge method of EN 12543-4 is intended for field applications when the users have to observe the effective focal spot on a regular basis and the pinhole method is non-practical.

The edge measurement method of EN 12543-5 is intended for measurement of effective focal spot sizes between 5  $\mu\text{m}$  and 300- $\mu\text{m}$  and mainly for the use with  $\mu$ -Focus tubes (up to 100- $\mu\text{m}$ ) and mini focus tubes with spot sizes of 100- $\mu\text{m}$  to 300- $\mu\text{m}$ .

In the overlapping ranges, the different parts of ~~the~~ EN 12543 series ~~respective~~and ISO 32543 series provide comparable values within  $\pm 20\%$  tolerance.

# iTeh Standards (<https://standards.iteh.ai>) Document Preview

[ISO/PRF 32543-1](https://standards.iteh.ai/catalog/standards/iso/96d25088-a4f2-4ef4-889d-68a657f77317/iso-prf-32543-1)

<https://standards.iteh.ai/catalog/standards/iso/96d25088-a4f2-4ef4-889d-68a657f77317/iso-prf-32543-1>

# Non-destructive testing — Characteristics of focal spots in industrial X-ray systems for use in non-destructive testing

## Part 1: Pinhole camera radiographic method

### 1 Scope

This document specifies a method for the measurement of effective focal spot dimensions above 0,1 mm of X-ray systems up to and including 1000 kV tube voltage by means of the pinhole camera method with digital evaluation. The tube voltage applied for this measurement is restricted to 200 kV for visual film evaluation and can be selected higher than 200 kV if digital detectors are used.

The imaging quality and the resolution of X-ray images depend highly on the characteristics of the effective focal spot, in particular the size and the two-dimensional intensity distribution as seen from the detector plane. Compared to the other methods specified in the EN 12543 series and the ISO 32543 series, this method allows to obtain an image of the focal spot and to see the state of it (e.g. cratering of the anode).

This test method provides instructions for determining the effective size (dimensions) of standard (macro focal spots) and mini focal spots of industrial X-ray tubes. This determination is based on the measurement of an image of a focal spot that has been radiographically recorded with a “pinhole” technique and evaluated with a digital method.

For the characterization of commercial X-ray tube types (i.e. for advertising or trade), the specific FS (Focal spot) values of Annex A can be used.

### 2 Normative references

The following documents are referred to in the text in such a way that some or all of their content constitutes requirements of this document. For dated references, only the edition cited applies. For undated references, the latest edition of the referenced document (including any amendments) applies.

ISO 19232-5, *Non-destructive testing — Image quality of radiographs — Part 5: Determination of the image unsharpness and basic spatial resolution value using duplex wire-type image quality indicators*

### 3 Terms and definitions

For the purposes of this document, the following terms and definitions apply.

ISO and IEC maintain terminology databases for use in standardization at the following addresses:

- ISO Online browsing platform: available at <https://www.iso.org/obp>
- IEC Electropedia: available at <https://www.electropedia.org/>

#### 3.1

##### actual focal spot

X-ray emitting area of the anode as viewed from a position perpendicular to the anode surface

Note 1 to entry: The actual focal spot is also called thermal focal spot in other literature.

### 3.2

#### effective focal spot

X-rays emitting area of the anode as viewed from the image plane of the detector

Note 1- to -entry:- The effective focal spot is also called optical focal spot in other literature.

### 3.3

#### effective focal spot size

focal spot size measured in accordance with this document

### 3.4

#### nominal focal spot size

##### SS

characteristic value for X-ray tubes having measured spot sizes within a defined range

### 3.5

#### focal spot class

##### FS

number used to classify X-ray tubes based on the nominal focal spot size

### 3.6

#### basic spatial resolution of the detector

##### $SR_{b,detector}$

##### $SR_{b,detector}$

smallest degree of visible detail within a digital image, determined with the duplex wire image quality indicator (IQI) according to ISO 19232-5 located on the detector (magnification = 1), from the smallest number of the duplex wire pair with less than 20% modulation depth in a linearized profile and it corresponds to  $\frac{1}{2}$  of the detector unsharpness

## 4 Test equipment

### 4.1 Essential characteristics of the pinhole

The pinhole camera shall consist of a diaphragm with a pinhole having followed essential dimensions  $P$  and  $H$  according to [Table 1](#) dependent from the effective focal spot size.

Table 1- — Dimensions of the pinhole

| Focal spot size | Diameter $P$  | Height $H$    |
|-----------------|---------------|---------------|
| mm              | $\mu\text{m}$ | $\mu\text{m}$ |
| 0,1 to 0,3      | $10 \pm 5$    | $20 \pm 5$    |
| > 0,3 to 1,0    | $30 \pm 5$    | $75 \pm 10$   |
| > 1,0           | $100 \pm 5$   | $500 \pm 10$  |

The essential dimensions  $P$  and  $H$  are shown in [Figure 1](#).

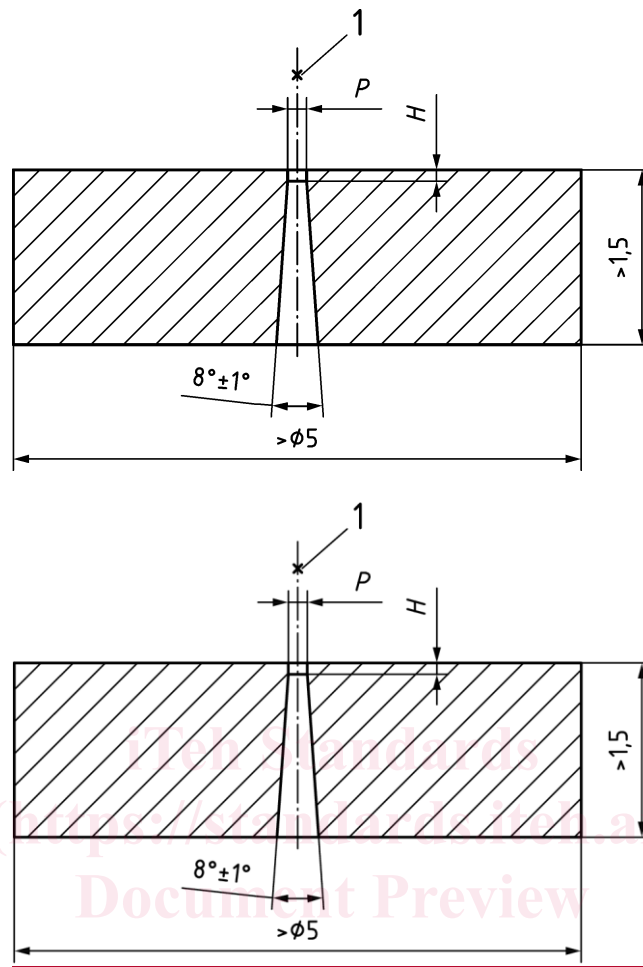

**Key**

- 1 focal spot  
 P pinhole diameter  
 H pinhole height

**Figure 1 — Essential dimensions of a pinhole diaphragm**

The pinhole diaphragm shall be made of tungsten or of a similar absorbent material (e.g. gold, platinum, tantalum or related alloys).

#### 4.2 Alignment and position of the pinhole camera

The angle between the beam direction and the pinhole axis (see [Figure 2](#)) shall be smaller than  $\pm 1,5^\circ$ . When deviating from [Figure 2](#), the direction of the beam shall be indicated.

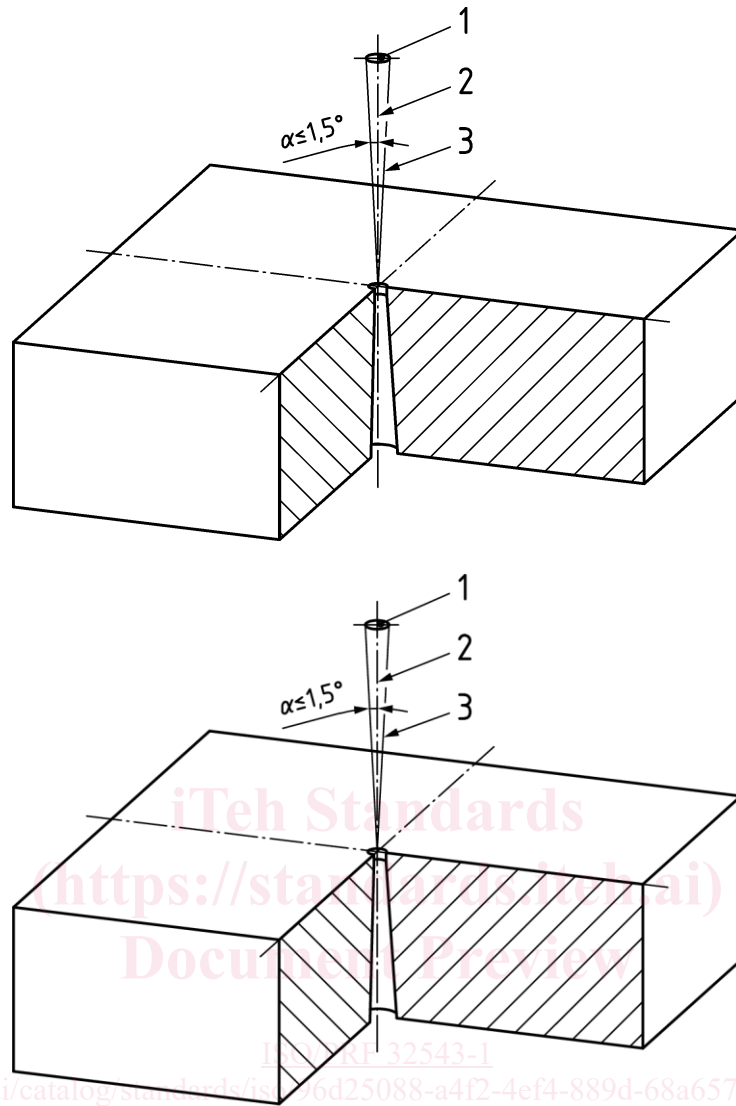

**Key**

- 1 focal spot
- 2 beam direction
- 3 maximum deviation of the axis of the pinhole

**Figure 2 — Alignment of the pinhole camera**

The incident face of the pinhole diaphragm shall be placed at a distance  $m$  from the focal spot so that the variation of the magnification over the extension of the actual focal spot does not exceed  $\pm 5\%$  in the beam direction. In no case shall this distance be less than 100 mm.

**4.3 Position of the radiographic image detector**

The radiographic image detector [film, imaging plate (CR) or digital detector array (DDA)] shall be placed normal to the beam direction at a distance  $n$  from the incident face of the pinhole diaphragm determined from the applicable magnification according to [Figure 3 and Table 2](#).