



Designation: ~~D6413/D6413M – 13a~~ D6413/D6413M – 13b

## Standard Test Method for Flame Resistance of Textiles (Vertical Test)<sup>1</sup>

This standard is issued under the fixed designation D6413/D6413M; the number immediately following the designation indicates the year of original adoption or, in the case of revision, the year of last revision. A number in parentheses indicates the year of last reappraisal. A superscript epsilon ( $\epsilon$ ) indicates an editorial change since the last revision or reappraisal.

### 1. Scope

1.1 This test method is used to measure the vertical flame resistance of textiles.

1.1.1 As a part of the measure of flame resistance, afterflame and afterglow characteristics are evaluated.

1.2 This standard shall be used to measure and describe the response of materials, products, or assemblies to heat and flame under controlled laboratory conditions and shall not be used to describe or appraise the fire hazard or fire risk of materials, products, or assemblies under actual fire conditions.

1.3 The values stated in either SI units or inch-pound units are to be regarded separately as standard. The values stated in each system may not be exact equivalents; therefore, each system shall be used independently of the other. Combining values from the two systems may result in non-conformance with the standard.

1.4 *This standard does not purport to address all of the safety concerns, if any, associated with its use. It is the responsibility of the user of this standard to establish appropriate safety and health practices and determine the applicability of regulatory limitations prior to use.*

### 2. Referenced Documents

2.1 *ASTM Standards:*<sup>2</sup>

[D123 Terminology Relating to Textiles](#)

[D1776 Practice for Conditioning and Testing Textiles](#)

[D4391 Terminology Relating to The Burning Behavior of Textiles](#)

### 3. Terminology

3.1 ~~Definitions~~—For definitions of terms relating to the ~~combustion-burning behavior~~ of textiles, see Terminology [D4391](#). For definitions of other textile terms used in this test method, refer to Terminology [D123](#).

3.1.1 The following terms are relevant to this standard.

3.1.1.1 *afterflame, n*—persistent flaming of a material after the ignition source has been removed.

3.1.1.2 *after-flame time, n*—the length of time for which a material continues to flame after the ignition source has been removed.

3.1.1.3 *afterglow time, n*—the time afterglow continues after the removal of the ignition source and the cessation of flaming.

3.1.1.4 *char length, n*—in measuring flame resistance of textiles, the distance from the fabric edge, which is directly exposed to the flame to the furthest point of visible fabric damage after a specified tearing force has been applied.

3.1.1.5 *flame application time, n*—the time interval for which the ignition flame is applied to a material.

3.1.1.6 *melting, n*—a liquification of material under the influence of heat.

3.2 *Definitions of Terms Specific to This Standard:*

3.2.1 *afterflame, n*—persistent flaming of a material after the ignition source has been removed.

3.2.2 *after-flame time, n*—the length of time for which a material continues to flame after the ignition source has been removed.

3.2.3 *afterglow, n*—glow in a material after the removal of an external ignition source or after the cessation (natural or induced) of flaming of the material.

3.2.4 *afterglow time, n*—the time afterglow continues after the removal of the ignition source and the cessation of flaming.

<sup>1</sup> This test method is under the jurisdiction of ASTM Committee [D13](#) on Textiles and is the direct responsibility of Subcommittee [D13.52](#) on Flammability. Current edition approved Feb. 15, 2013; May 1, 2013. Published March 2013; June 2013. Originally approved in 1999. Last previous edition approved in 2013 as [D6413/D6413M – 13](#); [D6413/D6413M – 13a](#). DOI: [10.1520/D6413-D6413M-13A](#); [10.1520/D6413-D6413M-13B](#).

<sup>2</sup> For referenced ASTM standards, visit the ASTM website, [www.astm.org](http://www.astm.org), or contact ASTM Customer Service at [service@astm.org](mailto:service@astm.org). For *Annual Book of ASTM Standards* volume information, refer to the standard's Document Summary page on the ASTM website.

3.2.5 *char length, n*—in measuring flame resistance of textiles, the distance from the fabric edge, which is directly exposed to the flame to the furthest point of visible fabric damage after a specified tearing force has been applied.

3.2.6 *charring, n*—the formation of carbonaceous residue as the result of pyrolysis or incomplete combustion.

3.2.7 *flame, n*—as related to ignition of textiles, a controlled hot, luminous zone of gas or matter in gaseous suspension, or both, of constant size and shape that is undergoing combustion as evidenced by a low-intensity heat flux of less than 1 kw, such as candle flame or match flame.

3.2.8 *flame application time, n*—the time interval for which the ignition flame is applied to a material.

3.2.9 *flame resistance, n*—the property of a material whereby flaming combustion is prevented, terminated, or inhibited following application of a flaming or nonflaming source of ignition, with or without subsequent removal of the ignition source.

3.2.10 *glow, n*—visible, flameless combustion of the solid phase of a material.

3.2.11 *ignition, n*—the initiation of combustion.

3.2.12 *melting, n*—a liquification of material under the influence of heat.

3.2.13 *smoldering, n*—the combustion of a solid material without accompaniment of flame but generally with the production of smoke.

3.2 For all terminology related to textiles, refer to Terminology [D123](#).

#### 4. Summary of Test Method

4.1 A specimen is positioned vertically above a controlled flame and exposed for a specified period of time. The flame then is removed, and afterflame time and afterglow time are measured.

4.2 Char length is measured under a specified force.

4.3 Any evidence of melting or dripping is noted.

#### 5. Significance and Use

5.1 This test method determines the response of textiles to a standard ignition source, deriving measurement values for afterflame time, afterglow time, and char length.

5.2 The vertical flame resistance, as determined by this test method, only relates to a specified flame exposure and application time.

5.3 This test method maintains the specimen in a static, draft-free, vertical position and does not involve movement except that resulting from the exposure.

5.4 Test Method D6413 has been adopted from Federal Test Standard No. 191A method 5903.1, which has been used for many years in acceptance testing. The between-laboratory precision of this test method has not been established. Refer to Section 14 for single-laboratory precision.

5.4.1 If there are differences or practical significance between reported test results for two laboratories (or more), comparative tests should be performed to determine if there is a statistical bias between them, using competent statistical assistance. As a minimum, the test samples used should be as homogeneous as possible, that are drawn from the material from which the disparate test results are obtained, and that are assigned randomly in equal numbers to each laboratory for testing. Other materials with established test values may be used for this purpose. The test results from the two laboratories should be compared using a statistical test for unpaired data, at a probability level chosen prior to the testing series. If a bias is found, either its cause must be found and corrected, or future test results must be adjusted in consideration on the known bias.

#### 6. Apparatus

6.1 *Test Cabinet and Accessories*, fabricated in accordance with the requirements specified in [Figs. 1-6](#). Galvanized sheet metal or other suitable metal can be used. The entire inside back wall of the cabinet shall be painted black to facilitate the viewing of the test specimen and pilot flame.

6.1.1 The test cabinet shall be set up in a laboratory hood or with comparable equipment so that combustion gases can be removed from the test lab environment. Precautions must be taken to minimize the draft through the laboratory hood while testing. Open doors or windows are examples of unnecessary causes of drafts and must be avoided. A ventilation smoke tube kit<sup>3</sup> may be used to check for the presence of drafts.

6.2 *Burner*, equipped with a needle valve to adjust flame height (see [Fig. 4](#)).

6.2.1 The burner shall be constructed by combining a 10 mm [0.38 in.] inside diameter barrel  $76 \pm 6$  mm [ $3 \pm 0.25$  in.] long with a base from an adjustable valve burner. A Tirrill burner is recommended, but a Bunsen burner modified to conform to this test method also will suffice.

<sup>3</sup> A ventilation smoke tube kit is available from A-Line Safety Appliance Company, Pittsburgh, PA 15230.

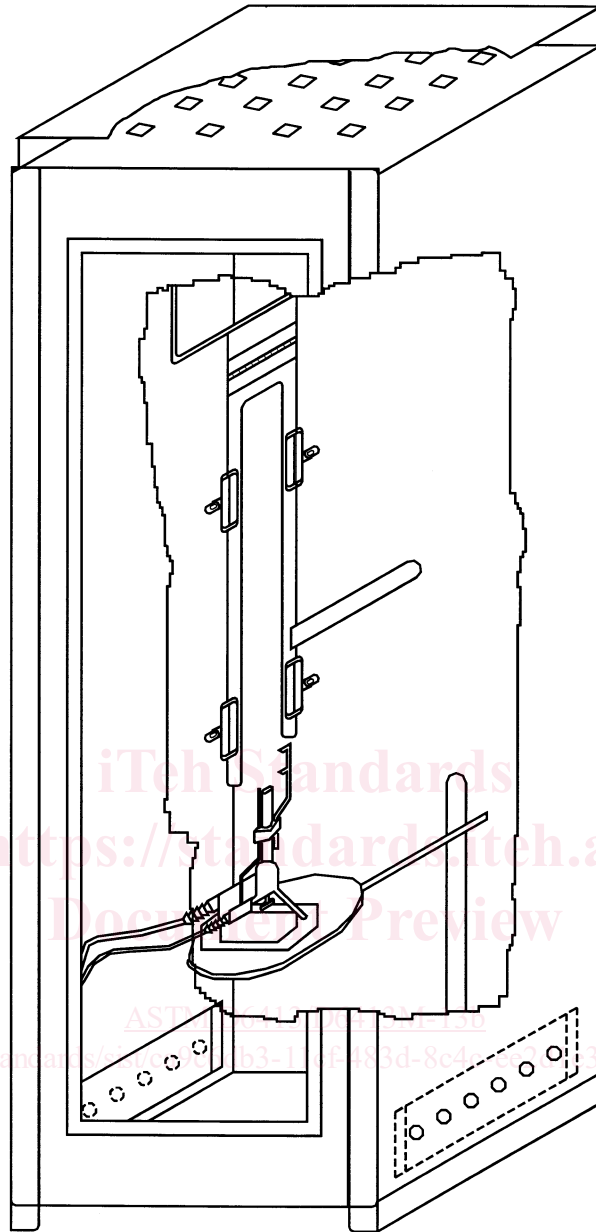

FIG. 1 Test Apparatus

6.2.2 The pilot light tube shall have an inside diameter of approximately 1.5 mm [0.06 in.] and shall be spaced 3 mm [0.12 in.] away from the burner edge.

6.2.2.1 The pilot light tube shall be located vertically next to the burner as shown in Fig. 4.

6.2.3 Gas controls and connections shall be as specified in Fig. 5. The solenoid valve shall be capable of being fully opened or fully closed in less than 0.2 s and activated by an adjustable timer. The solenoid valve should be positioned as close to the burner as possible using a  $50 \pm 13$  mm [ $2 \pm 0.5$  in.] length of 6.5 mm [0.25 in.] inside diameter, 13 mm outside diameter [0.5 min. outside diameter] methane safe hose (Fig. 6). In older cabinets where the solenoid valve is located outside the test chamber a retrofit can be done to accommodate this change. (See Fig. 5 and Fig. 6.)

6.2.4 On the side of the barrel of the burner, opposite the burner pilot light there shall be a flame height gage constructed of metal spaced approximately 13 mm [0.50 in.] from the barrel and extending above the burner. The gage shall have two prongs approximately 8 mm [0.32 in.] long marking the distances of 19 mm [0.75 in.] and 38 mm [1.50 in.] above the top of the burner.

6.2.5 The burner shall be movable when placed in the cabinet and capable of adjustments to center the burner directly below the center bottom edge of the specimen when performing the tests.

6.3 *Gas Regulator Valve System*, a control system with a delivery rate designed to furnish gas to the burner under a pressure of  $17.2 \pm 1.7$  kPa [ $2.5 \pm 0.25$  lbf/in.<sup>2</sup>] at the burner inlet. The manufacturer's recommend delivery rate for the valve system shall include the required pressure.

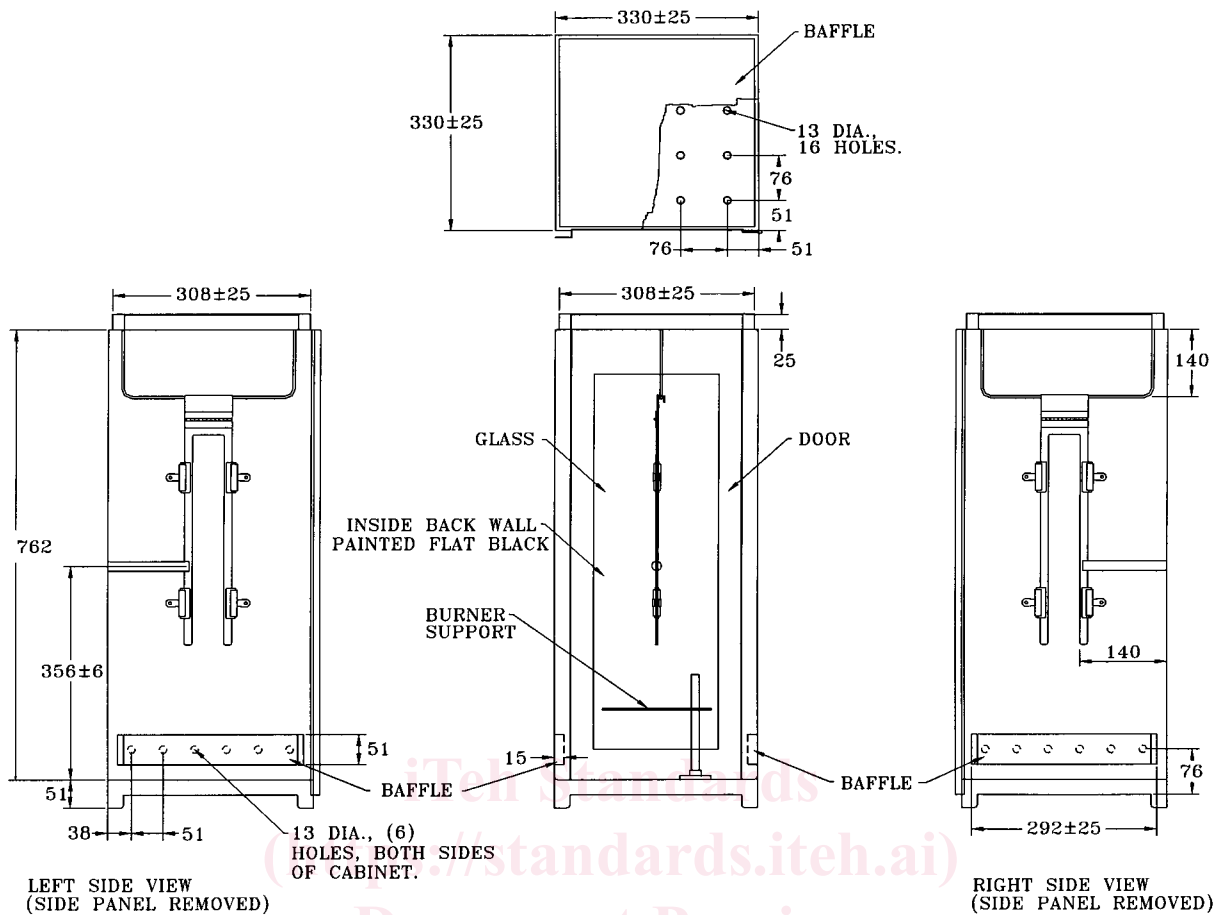

FIG. 2 a Test Apparatus Construction Details

6.4 Gas Mixture, methane, 99 % pure.

6.5 Test Specimen Holder, constructed as shown in Fig. 3. The assembly is shown in Figs. 1 and 2.

6.6 Specimen Holder Clamps, capable of firmly holding the test specimen in the test specimen holder.

6.7 Laboratory Hood, in which to carry out the test.

6.8 Stop Watch, or other device to measure the burning time to 0.2 s.

6.9 Measuring Scale, graduated in increments of at least 3 mm [0.12 in.] to measure the length of char.

6.10 Metal Hooks and Weights—Metal hooks and a range of weights to produce a series of total loads, which will be used to determine char length. The metal hooks shall consist of 1-mm [0.04-in.] diameter steel wire, 76 mm [3 in.] long. The hook is formed by bending the wire to 45° angle forming a hook 3 mm [0.5 in.] from one end. This hook is used for puncturing the fabric.

6.11 Flame Impingement Timer, a timer and electrical gas solenoid used to control the interval, which gas is supplied to the burner.

## 7. Hazards

7.1 Normal precautions applicable to pressurized flammable gases, open flames, hot flames, hot surfaces, burning fabrics and combustion, off gases and solid residue shall be employed.

7.2 Conduct the tests in a hood to contain the gases evolved during testing and for exhaust of the gases after each test.

## 8. Preparation of Apparatus

8.1 Adjust gas pressure to  $17.2 \pm 1.7$  kPa [ $2.50 \pm 0.25$  lbf/in.<sup>2</sup>] and ignite pilot flame. Adjust the pilot flame to a height of approximately 3 mm [0.12 in.] when measured from its lowest point. Be sure that the tip does not alter shape of the test flame during the 12 s exposure time.

8.1.1 Adjust the burner flame using the needle valve in the base of the burner to achieve a flame height of 38 mm [1.50 in.]. This height is achieved by fully closing the air opening on the burner tube base and fully opening the solenoid valve.

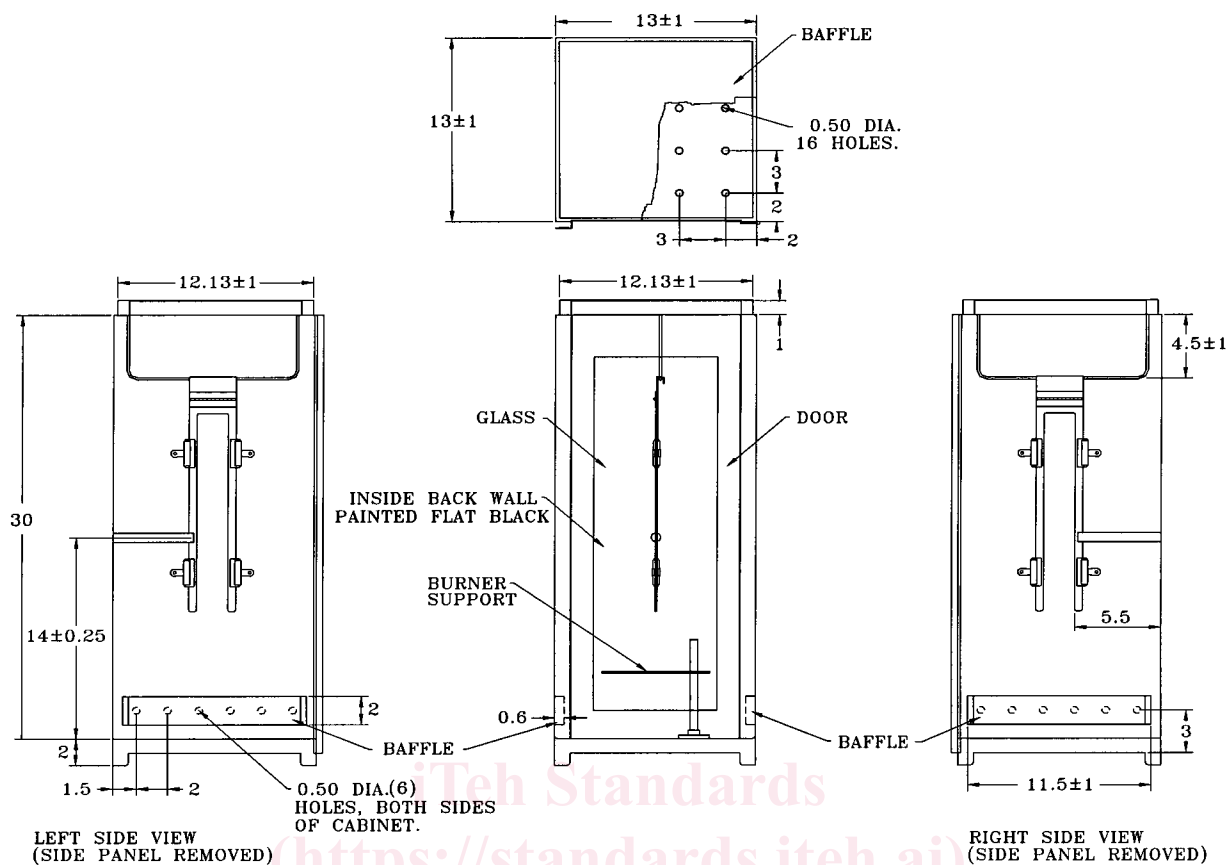

FIG. 2 b Test Apparatus Construction Details (continued)

NOTE 1—Tape may be used to close off the air openings on the burner.

8.1.1.1 The 38-mm [1½-in.] flame height is obtained by adjusting the flame level with the top of the metal prong. (See Fig. 7.) It is important that the flame height be adjusted with the tip of the flame level with the tip of the metal prong. The tip of the methane flame is blue, transparent, and difficult to see; it is more easily seen if there is no light on the flame, for example in a darkened room. An easy way to accomplish this is by turning off all nearby lights.

8.1.2 Position the burner so that the middle of the lower edge of the specimen holder is centered 19 mm [0.75 in.] above the burner.

NOTE 2—It may be necessary to turn off nearby lights to make sure of the accuracy of intersect of the midpoint of the flame with the mounting clamp.

8.2 Adjust the timer to provide a  $12 \pm 0.2$ -s flame to the specimen.

NOTE 3—Using a hand-held timer or stopwatch, verify the flame time.

8.2.1 Do this by measuring the interval between the opening and closing of the solenoid with an accurate laboratory timer or stopwatch.

## 9. Sampling

9.1 *Primary Sampling Unit*—Consider rolls of fabric or fabric components of fabricated assemblies to be the primary sampling unit, as applicable.

9.2 *Laboratory Sampling Unit*—As a laboratory sampling unit take from rolls at least one full-width piece of fabric that is 1 m [1 yd] long along the selvage (machine direction), after removing first a 1-m [1-yd] length. For fabric components of fabricated assemblies the entire assembly may be used.

9.3 *Test Specimens*—From each laboratory sampling unit, cut five lengthwise and five widthwise test specimens 76 mm [3.0 in.] by 300 mm [12 in.]. For woven fabrics, the long dimensions are cut parallel to the warp yarns for lengthwise tests and parallel to the filling yarns for widthwise tests. Take lengthwise specimens from different positions across the width of the fabric. Consider the long direction as the direction of the test. Label to maintain specimen identity.

9.3.1 Cut specimens representing a broad distribution diagonally across the width of the laboratory sampling unit. Ensure specimens are free of folds, creases, or wrinkles. Avoid getting oil, water, grease, etc., on the specimens when handling.

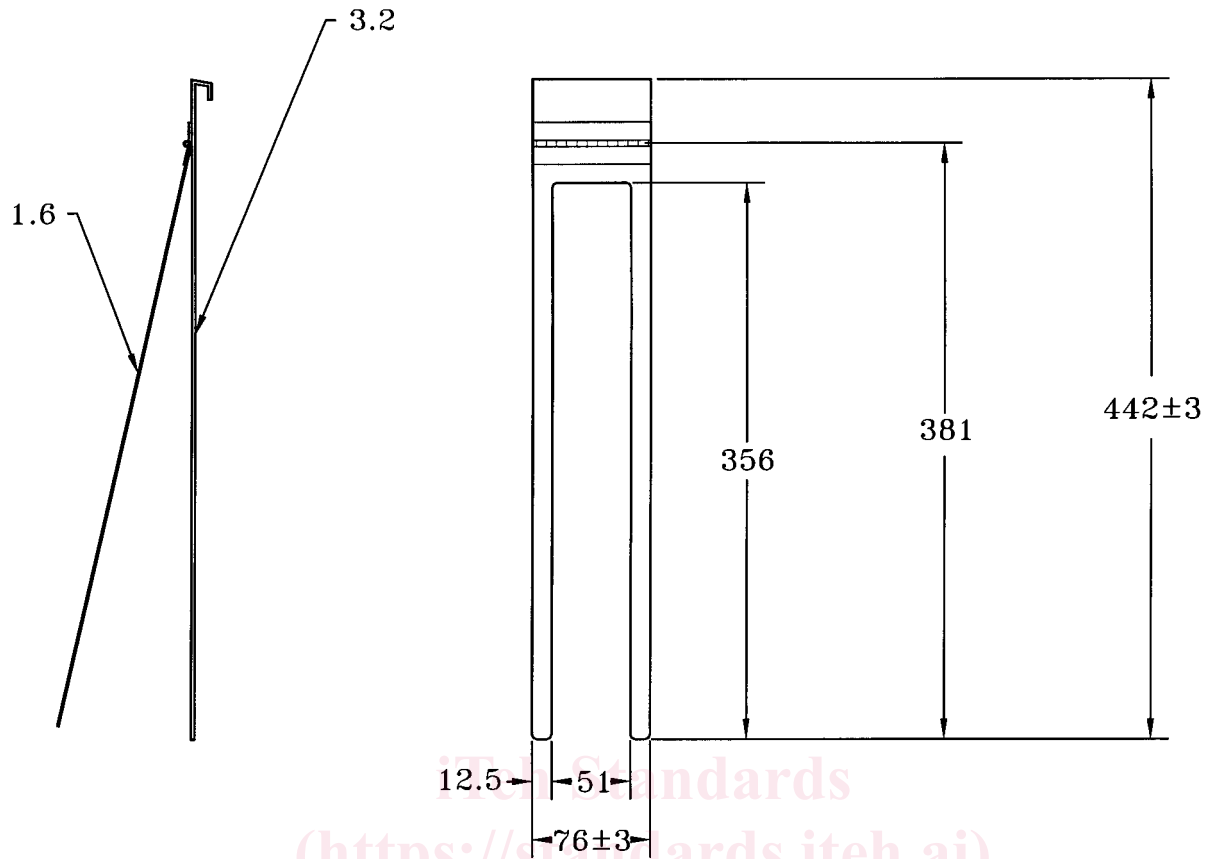

ALL DIMENSIONS IN mm.

FIG. 3 a Specimen Holder Construction Details

9.3.2 If the fabric has a pattern, ensure that the specimens are a representative sampling of the pattern.

## 10. Conditioning

10.1 Bring the laboratory sampling units or test specimens to moisture equilibrium as directed in Practice D1776, or for a minimum of 24 h using the temperature and relative humidity specified in D1776, except no preconditioning is necessary.

10.2 Each specimen to be tested shall be exposed to the test flame within 4 min after removal from the standard atmosphere or placed in a desiccator without desiccant or equivalent after conditioning for storage until testing and transfer to the testing area.

## 11. Procedure

11.1 Mount and expose each specimen to the flame within 4 min of removal from the conditioning area or storage.

11.2 Clamp the test specimen between the two halves of the holder, with the bottom of the specimen even with the bottom of the holder. With the holder held vertically, secure the specimen in the holder with a minimum of four clamps. Position two clamps near the top of the holder, one on each side to stabilize the specimen. Similarly, position two clamps at the bottom of the holder, one on each side.

11.3 Turn off the hood ventilation. Insert the specimen holder containing the specimen into the test cabinet and position the burner with the middle of the lower edge of the test specimen centered 19 mm [0.75 in.] above the burner and leveled with the bottom metal prong.

11.4 Start the flame impingement timer and expose the specimen for the  $12 \pm 0.2$  s. Observe the specimen for melting or dripping during the flame exposure. Record any observations. Immediately after the flame is removed, start a stopwatch for measurement of the afterflame and afterglow time.

11.5 Observe how long the specimen continues to flame after the 12 s exposure time. Record the afterflame time to within 0.2 s.

11.6 Observe how long the specimen continues to glow after the afterflame ceases or after removal of the flame if there is no afterflame. Record this afterglow time to the nearest 0.2 s. Do not extinguish the glow because of potential effect on char length.