



Designation: D3953 – 13

Standard Specification for Strapping, Flat Steel and Seals¹

This standard is issued under the fixed designation D3953; the number immediately following the designation indicates the year of original adoption or, in the case of revision, the year of last revision. A number in parentheses indicates the year of last reapproval. A superscript epsilon (ϵ) indicates an editorial change since the last revision or reapproval.

This standard has been approved for use by agencies of the U.S. Department of Defense.

1. Scope

1.1 This specification covers flat steel strapping and seals intended for use in closing, reinforcing, bundling articles for shipment, unitizing, palletizing, and bracing for carloading, truckloading, lifting, and lashing.

1.2 This specification includes strapping and seals made from carbon steel and applies only to the types and sizes as cataloged by strapping suppliers to be a standard, commercially available product. It does not include “specialty”-type strapping as developed for special applications or strapping produced from alloy metals.

1.3 The values stated in inch-pound units are to be regarded as standard.

1.4 Performance characteristics may be negatively affected by extremes of temperatures, such as occur during the annealing of steel.

1.5 The following safety hazards caveat applies only to the test method portion, Sections 11, 12, and 13, of this specification: *This standard does not purport to address all of the safety concerns, if any, associated with its use. It is the responsibility of the user of this standard to establish appropriate safety and health practices and determine the applicability of regulatory limitations prior to use.*

2. Referenced Documents

2.1 ASTM Standards:²

- A90/A90M Test Method for Weight [Mass] of Coating on Iron and Steel Articles with Zinc or Zinc-Alloy Coatings
- A109/A109M Specification for Steel, Strip, Carbon (0.25 Maximum Percent), Cold-Rolled
- A239 Practice for Locating the Thinnest Spot in a Zinc

¹ This specification is under the jurisdiction of ASTM Committee D10 on Packaging and is the direct responsibility of Subcommittee D10.25 on Palletizing and Unitizing of Loads.

Current edition approved April 1, 2013. Published June 2013. Originally approved in 1983. Last previous edition approved in 2012 as D3953 – 12. DOI: 10.1520/D3953-13.

² For referenced ASTM standards, visit the ASTM website, www.astm.org, or contact ASTM Customer Service at service@astm.org. For *Annual Book of ASTM Standards* volume information, refer to the standard’s Document Summary page on the ASTM website.

- (Galvanized) Coating on Iron or Steel Articles³
- B504 Test Method for Measurement of Thickness of Metallic Coatings by the Coulometric Method
- D996 Terminology of Packaging and Distribution Environments
- D3951 Practice for Commercial Packaging
- D4332 Practice for Conditioning Containers, Packages, or Packaging Components for Testing
- D4675 Guide for Selection and Use of Flat Strapping Materials¹
- D6039/D6039M Specification for Open and Covered Wood Crates
- D6880 Specification for Wood Boxes
- E177 Practice for Use of the Terms Precision and Bias in ASTM Test Methods
- E691 Practice for Conducting an Interlaboratory Study to Determine the Precision of a Test Method
- 2.2 Military Standard:³
- MIL-STD-105 Sampling Procedures and Tables for Inspection by Attributes
- 2.3 AAR Rules:⁴
- AAR Open Top Loading Rules Manual, Section No. 1, General Rules for Loading All Commodities, Part 2, Rule 17 and Section No. 7, Rules for Loading All Commodities on Open Top Trailers and Containers for Rail Transport, Part 2, Rule 117

3. Terminology

3.1 General definitions for packaging and distribution environments are found in Terminology D996.

4. Strapping Classifications

4.1 Strapping shall be of the following types, finish and sizes:

Type 1, Flat Strapping: Power Machine and Hand Application:

- Regular-duty
- Regular-duty high-strength

³ Available from Standardization Documents Order Desk, Bldg. 4 Section D, 700 Robbins Ave., Philadelphia, PA 19111-5094, Attn: NPODS.

⁴ Available from the Association of American Railroads (AAR), Safety and Operations, 50 F St., NW, Washington, DC 20001-1564.

Heavy-duty
USLM (Unit Strap Lifting Method) (See **Note 1**.)

NOTE 1—For USLM applications, refer to manufacturer’s standard practice.

Type 2: Nail-On

4.1.1 *Strapping Finish, Lubricated or Dry* (see **8.3**):

4.1.1.1 *Finish A—Organic (Pigmented or Unpigmented Paint)*

4.1.1.2 *Finish B—Galvanized (Hot Dipped or Electro-Deposit Galvanized)* (see **8.10**):

Grade 1—Heavy Coating

Grade 2—Moderate Coating

Grade 3—Commercial Coating

4.1.1.3 *Finish C—Organic Painted Metallic Filled (Aluminum or Zinc)*

4.1.1.4 *Finish D—Uncoated*

4.1.2 *Strapping Sizes*— Strapping shall have the widths and thicknesses in accordance with sizes shown in **Table 1**, **Table 2**, **Table 3**, and **Table 4**.

5. Seal Classifications

5.1 Seals shall be of the following classes, finishes, types, and styles:

5.1.1 *Seal Classes*:

R—Regular duty

H—Heavy duty

5.1.2 *Seal Finishes*:

Finish A—Organic (painted)

Finish B—Galvanized (hot dipped or electro-deposit galvanized)

Grade 1—Heavy coating

Grade 2—Moderate coating

Grade 3—Manufacturer’s standard commercial practice

Finish C—Organic Painted Metallic Filled (Aluminum or Zinc)

Finish D—Uncoated

5.1.3 *Seal Styles*:

I—Snap-on or open

II—Thread-on or closed

III—Push-type or overlap

IV—Magazine-feed

V—Intersectional or cross-tie

5.2 *Seal Sizes*—Seals shall have widths in accordance with strapping width shown in **Table 1**, **Table 2**, **Table 3**, and **Table 4**.

6. Ordering Information

6.1 The inquiry and order shall indicate the following:

6.1.1 Strapping type, duty, finish, grade, lubrication (when applicable), dimension required, and quantity of each size (see Section 4).

6.1.2 Coil of strapping dimensions, weight and feet per pound, oscillated, ribbon wound, or cut-to-length (see Section 9, **Table 5** and **Table 6**, and **Fig. 1** and **Fig. 2**).

6.1.3 Seals (see Section 5) class, finish, grade (when applicable), type, style, and quantity by width (or nomenclature).

6.1.4 Make or model of strapping equipment that the strapping and seals must work in, if applicable.

6.1.5 Title, designation, and date of this specification.

6.1.6 For Department of Defense, indicate selection of preservation, packing, marking, and palletization, if applicable (see Section 16).

6.2 Sizes or physical properties, or both, other than those covered by this specification shall be as specified in the contract or order.

7. Materials and Manufacture

7.1 Materials shall be cold-rolled carbon steel of the quality normally used for this purpose in commercial practice, and the physical mechanical property requirements, as determined by tests, shall be within the allowable limits.

7.1.1 *Type 1 Regular-Duty Strapping* —Regular-duty strapping in **Table 1** shall be low-carbon cold-rolled steel (see **6.1.1**).

7.1.2 *Type 1 Regular-Duty High-Strength Strapping*—Regular-duty high strength strapping in **Table 2** shall be low to medium carbon cold-rolled steel.

7.1.3 *Type 1 Heavy-Duty Strapping* —Heavy-duty strapping in **Table 3** shall be cold-rolled, high carbon, or medium carbon high-manganese steel which has been fully heat-treated; for example, austenitized and quenched.

TABLE 1 Type 1 Regular-Duty Strapping Widths, Thickness, and Breaking Strengths

Width, in. (mm)	0.015 (0.38)	0.018 (0.46)	0.020 (0.51)	0.023 (0.58)	0.028 (0.71)	0.035 (0.89)
3/8 (9.52)	450 (2000)	540 (2400)	600 (2670)	690 (3070)		
1/2 (12.70)	600 (2670)	720 (3200)	800 (3560)	920 (4090)		
5/8 (15.87)	750 (3335)	900 (4000)	1000 (4450)	1150 (5115)		
3/4 (19.05)	900 (4000)		1200 (5340)	1380 (6140)	1680 (7470)	2100 (9340)

TABLE 2 Type 1 Regular Duty High-Strength Strapping Widths, Thickness and Break Strengths

Width, in. (mm)	Thickness, in. (mm)							
	0.016 (0.41)	0.017 (0.43)	0.018 (0.46)	0.020 (0.51)	0.023 (0.58)	0.025 (0.64)	0.031 (0.79)	0.035 (0.89)
	Breaking Strength, min, lbf (N)							
3/8 (9.52)		640 (2849)		750 (3366)				
1/2 (12.70)	800 (3559)	850 (3781)	900 (4003)	1000 (4448)	1150 (5115)			
5/8 (15.87)	1000 (4448)	1050 (4671)	1125 (5004)	1250 (5560)	1440 (6405)			
3/4 (19.05)	1200 (5339)	1275 (5671)	1350 (6005)	1500 (6672)	1725 (7673)	1875 (8340)	2325 (10342)	
1 1/4 (31.75)						3125 (13901)	3875 (17237)	4375 (19461)

TABLE 3 Type 1 Heavy-Duty Strapping Widths, Thickness, and Breaking Strengths

Width, in. (mm)	Thickness, in. (mm)										
	0.020 (0.51)	0.022 (0.56)	0.023 (0.58)	0.025 (0.64)	0.028 (0.71)	0.029 (0.75)	0.031 (0.79)	0.035 (0.89)	0.040 (1.02)	0.044 (1.12)	0.050 (1.27)
	Breaking Strength, min, lbf (N)										
1/2 (12.70)	1 280 (5 690)		1 470 (6 540)				1 950 (8 675)				
5/8 (15.87)	1 600 (7 120)		1 840 (8 185)								
3/4 (19.05)	2 000 (8 896)	2 280 (10 140)	2 280 (10 140)	2 280 (10 140)	2 280 (10 140)	2 850 (12 675)	2 850 (12 675)	2 850 (12 675)		4 050 (18 015)	
1 (25.4)						3 700 (16 455)	3 700 (16 455)				
1 1/4 (31.75)	3 200 (14 240)		3 680 (16 370)		4 750 (21 130)	4 750 (21 130)	4 750 ^A (21 130)	6 135 (27.295)	6 750 (30 025)	6 750 (30 025)	
2 (50.80)									10 600 (47 150)	10 600 (47 150)	

^A Heavy-duty, or heavy-duty/high elongation.

<https://standards.iteh.ai/catalog/standards/sist/725e2e8f-9535-4fb8-a01b-f67f0299e301/astm-d3953-13>

TABLE 4 Type 1 Extra-Heavy-Duty (USLM) Strapping Widths, Thickness, Breaking Strengths, and Minimum Seal Joint Strengths

Width, in. (mm)	Thickness, in. (mm)	Min. Break Strength, lb (N)	Min. Seal Joint Strength, lb (N)
1 1/4 (31.75)	0.044 (1.12)	8500 (37 800)	7650 (34 000)
1 1/4 (31.75)	0.050 (1.27)	9700 (43 150)	8730 (38 800)
1 1/4 (31.75)	0.057 (1.45)	11 000 (48 430)	9900 (44 000)

7.1.4 *Type 1 USLM Strapping*—USLM strapping in Table 4 shall be cold-rolled, high-carbon steel that has been fully heat-treated, austenized, and quenched.

7.1.5 *Type 2 Nail-On Strapping*—Unless otherwise specified, Type 2 nail-on strapping shall be strapping made from Type 1 regular-duty, regular-duty high-strength or Type 1 heavy-duty strapping, available in sizes 5/8 in. (15.87 mm) in width or greater with punched nail holes. Hole diameters and hole spacing can vary depending upon strap size and duty,

which shall be in accordance with manufacturer’s standard practice. However, nail holes shall be spaced at intervals no more than 3 in. (76 mm) apart.

7.1.6 *Seals for Type 1 Strapping* —Unless otherwise specified, seals for Type 1 strapping shall be made of steel in accordance with the manufacturer’s commercial practice.

8. Physical and Mechanical Properties

8.1 *Breaking Strength and Elongation, Type 1 Regular-Duty, Regular-Duty High-Strength, Heavy-Duty, and USLM Strapping* :

8.1.1 *Breaking Strength*—The breaking strength of the strapping shall be as shown in Table 1, Table 2, Table 3, and Table 4 when tested as specified in 13.3.

8.1.2 *Elongation*—The elongation in 6 in. (152 mm) for Type 1 strapping, when tested as specified in 13.4, shall be as follows:

TABLE 5 Number of Feet Per Pound (Metres per Kilogram) of Type 1 Strapping^A

NOTE 1—Number of feet per pound (metres per kilogram) is based on nominal dimensions and will vary slightly with the width and thickness of the strapping within the tolerances as described in 8.2.

Width, in. (mm)	Thickness, in. (mm)														
	0.010 (0.25)	0.012 (0.311)	0.015 (0.38)	0.018 (0.46)	0.020 (0.51)	0.022 (0.56)	0.023 (0.58)	0.025 (0.64)	0.028 (0.71)	0.029 (0.75)	0.031 (0.79)	0.035 (0.89)	0.040 (1.02)	0.044 (1.12)	0.050 (1.27)
Length per Unit Mass, ft/lb (m/kg), approximate															
3/8 (9.52)	78.5 (52.7)	65.4 (43.9)	52.4 (35.2)	43.6 (29.3)	39.3 (26.4)	34.1 (22.9)									
1/2 (12.70)	58.9 (39.6)	49.1 (33.0)	39.3 (26.4)	32.7 (22.0)	29.4 (19.7)	25.6 (17.2)			19.0 (12.7)						
5/8 (15.87)	47.1 (31.6)	39.3 (26.4)	31.4 (21.1)	26.2 (17.6)	23.6 (15.8)	20.5 (13.7)									
3/4 (19.05)			26.2 (17.6)	19.6 (13.1)		17.8 (11.9)	17.1 (11.5)	15.7 (10.5)	14.0 (9.4)	13.5 (8.95)	12.7 (8.5)	11.2 (7.5)			
1 (25.4)									10.1 (6.7)	9.5 (6.3)					
1 1/4 (31.75)					11.8 (7.9)	9.4 (6.3)		8.1 (5.5)	7.6 (5.1)	6.6 (4.4)	5.9 (4.0)	5.3 (3.5)	4.7 (3.1)		
2 (50.80)											3.3 (2.2)	2.9 (1.9)			

^A Commercial tolerances apply.

TABLE 6 Size of Coils and Package

Type Coils	Size of Strapping, in. (mm)	Inside Diameter, in (mm) (Commercial Tolerance)	Outside Diameter, max, in. (mm)	Coils Per Package, max	Coil Face Width	Coil Weight
Oscillated	3/8 by 0.015 (9.52 by 0.38) through 3/4 by 0.035 (19.05 by 0.89)	16 (406)	23 1/2 (597)	1		
Ribbon	3/4 by 0.022 (19.05 by 0.56) through 3/4 by 0.035 (19.05 by 0.89)	16 (406)	27 (686)	1		
Ribbon	1 by 0.029 (25.4 by 0.75) through 1 by 0.031 (25.4 by 0.79)	16 (406)	27 (686)	1		
	1 1/4 by 0.020 (31.75 by 0.51) through 1 1/4 by 0.057 (31.75 by 1.45)	16 (406)	27 (686)	1		
	2 by 0.044 (50.80 by 1.12) through 2 by 0.050 (50.80 by 1.27)	16 (406)	25 7/8 (657)	1		
Jumbos	3/8 by 0.015 (9.52 by 0.38) through 1 1/4 by 0.044 (31.75 by 1.12)	16 (406)	in accordance with manufacturers commercial practice	1	3 in. to 16 in.	350 lb. to 4000 lb.

**TYPICAL
RECOMMENDED
CRIMP TYPE JOINTS**



**TYPICAL
RECOMMENDED
NOTCH TYPE JOINTS**

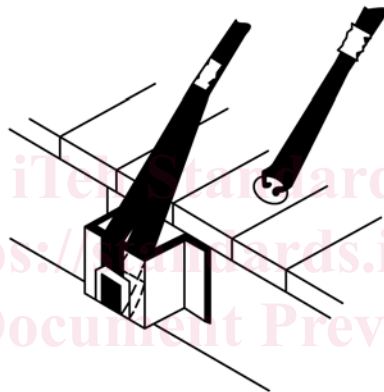

LOOP TYPE SECUREMENT, AS ILLUSTRATED,
REQUIRES ONLY ONE SEAL PROPERLY SEALED,
TO PROVIDE ACCEPTABLE JOINT EFFICIENCY.

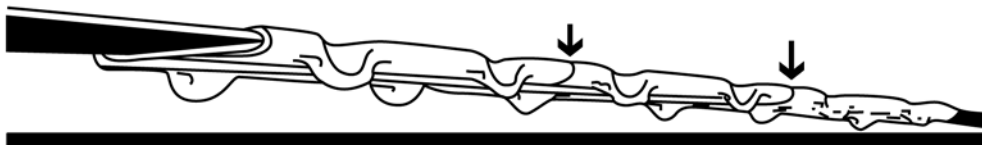

USLM Strapping Joint

FIG. 1 Recommended Seal Joints

Regular-duty (see 7.1.1)	0.5 to 4.0 %
Regular-duty high-strength (see 7.1.2)	0.5 to 8.0 %
Heavy-duty (see 7.1.3)	
Thickness less than 0.031 in. (0.79 mm)	5.0 to 12 %
Thickness 0.031 in. (0.79 mm) and greater	6.5 to 12 %
USLM Strapping (see 7.1.4)	6.0 to 12 %

8.2 *Tolerances, Type 1 Strapping, Widths*—The widths of the strapping shall not vary from that shown in Table 1, Table 2, and Table 3 by more than ± 0.005 in. (0.13 mm) for all cold-rolled strapping.

8.2.1 *Type 1 Strapping, Thickness*—The thickness of strapping sizes listed in Table 1, Table 2, and Table 3 shall not vary from nominal thickness by more than +0.002 in. (0.05 mm), -0.002 (0.05 mm) thickness, thickness of strapping sizes listed in Table 4 (USLM strapping) shall not vary by more than +0.004 in. (0.10 mm) and -0.000 in. (0.00 mm).

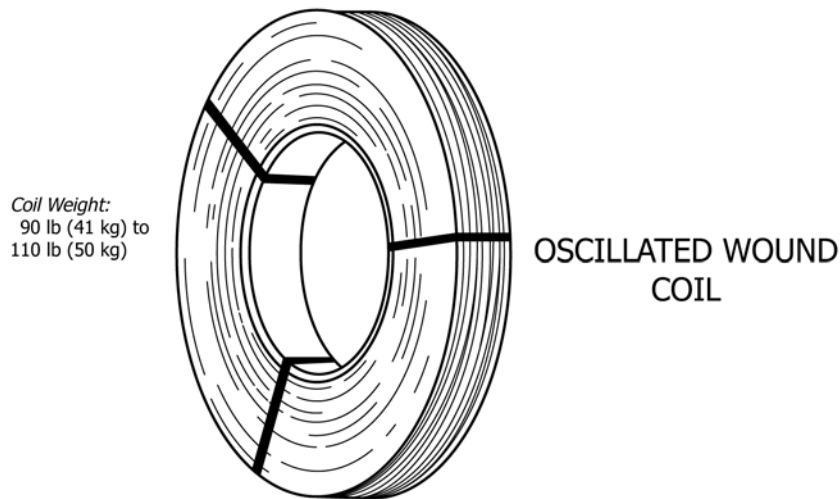

FIG. 2 Oscillated Wound Coil

8.3 *Lubrication*— Unless otherwise specified, Type 1 strapping shall have a coating of wax or wax-like lubricant applied to the surfaces that will render the strapping suitable for application with tension tools of the feed wheel (friction) type (see 4.1.2 and 6.1.4). The lubrication of the strapping is intended to facilitate the use of strapping tools in which the two bands of the strapping are held in contact with each other under pressure by frictional grips, and sliding of the faces of the strapping is necessary during the tensioning operation. Test in accordance with 13.9.

8.4 *Type 1 Strapping, Coils*—Each coil shall consist of one continuous piece of strapping. Coils with lengths of strapping welded together shall be considered as one-piece coil.

8.4.1 *Dimensional Requirements at the Weld*—The thickness at the weld shall be no more than one and one half the thickness of the strap. The width of strapping at the weld shall be subject to the same dimensional requirements as the remainder of the strapping and must be straight with no offsets or angular alignment. Metal splattering or extruded points causing increased thickness are not permissible. Only machine welds shall be acceptable.

8.4.2 *Weld Efficiency*— Strength of manufacturer’s process welded joints in coils of strapping shall have a joint efficiency of not less than 75 % based on the breaking strength shown in Table 1, Table 2, and Table 3 when tested as specified in 13.6. USLM strapping must not contain production welds.

8.5 *Identification Marking*—Each coil of AAR approved Type 1 heavy-duty, ½-in. (12.7-mm) wide by 0.020 in. (0.51 mm) in thickness and greater strapping shall be marked in accordance with the Association of American Railroads General Rule 17 and Rule 117. Each coil of USLM strapping shall be marked in repeating intervals of 18 in. (457 mm) to 40 in. (1016 mm) with identifying circles as follows:

Width	Thickness	Identification Marking
1¼ (31.75)	0.044 (1.12)	00
1¼ (31.75)	0.050 (1.27)	000
1¼ (31.75)	0.057 (1.45)	000M

8.5.1 The thickness and minimum breaking strength and name of the manufacturer of the strap shall be marked by circles or circles plus the letter “M”.

8.5.2 The circle diameter shall be a minimum of 0.80 in. (20 mm) to a maximum of 1.0 in. (25.4 mm) diameter.

8.5.3 Seal identification mark must be visible when seal is applied and while seal is in use.

8.6 *Type 2 Strapping:*

8.6.1 *Breaking Strength*—The breaking strength for Type 2 strapping shall be the same as shown in Table 1, Table 2 or Table 3 for the applicable strapping size and type, but shall be based on the cross-sectional metal area of the strapping taken across the hole. Breaking strength will be reduced proportionally in accordance with nail hole diameter.

8.6.2 *Tolerances*—The tolerances on width and thickness for Type 2 strapping shall be the same as for Type 1 strapping (see 8.2).

8.7 *Seals, Type 1 Strapping*—Seals intended for Type 1 strapping shall be made of steel to manufacturer’s commercial practice. Seal lengths shall be adequate for a single-notch joint (one pair of cut notches), a double-notch joint (two pairs of cut notches), a double-crimp joint (two pairs of crimps), a triple-crimp joint (three pairs of crimps), or a quadruple-crimp joint (four pairs of crimps). Unless otherwise specified, seals shall be suitable in size or design to satisfy the requirements of 8.9.2 and 8.9.3.

8.7.1 *Seal Width*—Seal width shall be adequate to allow the seal to slip on the applicable strapping and shall be compatible with the sealing tool used to provide the required joint strength.

8.7.2 *Seals, Regular-Duty High Strength, Heavy-Duty and USLM*, Seals shall be in thickness and hardness suitable for use with the type of strapping to which they are applied. USLM strapping seals are to be marked in accordance with 8.5.

8.8 *Application of Seals:*

8.8.1 *Style I*—Style I seals shall have one or both sides open so that the seal shall slip in the overlapping bands of strapping either during or after tensioning the strapping.