



Standard Specification for Cast Iron Soil Pipe and Fittings¹

This standard is issued under the fixed designation A74; the number immediately following the designation indicates the year of original adoption or, in the case of revision, the year of last revision. A number in parentheses indicates the year of last reappraisal. A superscript epsilon (ϵ) indicates an editorial change since the last revision or reappraisal.

This standard has been approved for use by agencies of the Department of Defense.

1. Scope

1.1 This specification covers cast iron soil pipe and fittings for use in gravity flow plumbing, drain, waste and vent sanitary, and storm water applications. It establishes standards covering material, manufacture, mechanical and chemical properties, coating, test methods, inspection, certification, product markings, dimensions, and dimensional tolerances for extra heavy and service cast iron soil pipe and fittings. These pipe and fittings are not intended for pressure applications as the selection of the proper size for sanitary drain, waste, vent, and storm drain systems allows free air space for gravity drainage.

1.2 This specification covers pipe and fittings of the following patterns and, when so designated, shall apply to any other patterns that conform with the applicable requirements given in this specification.

1.2.1 Pipe:

Extra heavy, 2½ ft (0.75 m), 3½ ft (1.0 m), 5 ft (1.5 m), 10 ft (3.0 m) lengths	Tables 1, 2
Service, 2½ ft (0.75 m), 3½ ft (1.0 m), 5 ft (1.5 m), 10 ft (3.0 m)	1, 2
Outside dimensions (for detailing)	X1.1

1.2.2 Fittings:

¼ bends; long ¼ bends	Tables 3, 4
¼ bends, long low-hub	5
¼ bends, low heel; high heel	6, 7
¼ bends, short sweep; long sweep	8
¼ bends, reducing long sweep	9
½ bends	10
⅝ bends	10
⅞ bends; long ⅞ bends	11
⅞ bends	11
Y branches	12, 13
Y branches, combination ⅞ bends, single	14
Y branches, combination ⅞ bends, double	14
Sanitary T branches, single	15
Sanitary T branches, double	15
Sanitary T branches, cleanout	16
Tapped sanitary T branches, single	17
Tapped sanitary T branches, double	17
T branches, single and double	18
Tapped T branches, single	19
Tapped T branches, double	19
T branches, cleanout	20
-45° offset fitting	21
Double hubs	22
Long double hubs	22
Reducers	23
Increases	24, 25
P traps	26, 27

¹ This specification is under the jurisdiction of ASTM Committee A04 on Iron Castings and is the direct responsibility of Subcommittee A04.12 on Pipes and Tubes. Current edition approved April 1, 2013. Published June 1, 2013. Originally approved in 1917. Last previous edition approved in 2009 as A74 – 09: A74 – 13. DOI: 10.1520/A0074-13.10.1520/A0074-13A.

Deep seal P traps	Tables
Running traps	28
Screw plugs (brass)	29
Blind plugs	30
Iron-body ferrules	31
Side inlets	32
Closet bends	Fig. 3
Tapping bosses	33
Reducing ¼ bend SV	34
Combination Y and ⅛ bend	35
'H' branch fitting	36
	37

1.3 The values stated in inch-pound units are to be regarded as standard. The values given in parentheses are mathematical conversions to SI units that are provided for information only and are not considered standard.

2. Referenced Documents

2.1 ASTM Standards:²

[A48/A48M Specification for Gray Iron Castings](#)

[A644 Terminology Relating to Iron Castings](#)

[D1248 Specification for Polyethylene Plastics Extrusion Materials for Wire and Cable](#)

[D3960 Practice for Determining Volatile Organic Compound \(VOC\) Content of Paints and Related Coatings](#)

[E8 Test Methods for Tension Testing of Metallic Materials](#)

[E1645 Practice for Preparation of Dried Paint Samples by Hotplate or Microwave Digestion for Subsequent Lead Analysis](#)

[E2349 Practice for Safety Requirements in Metal Casting Operations: Sand Preparation, Molding, and Core Making; Melting and Pouring; and Cleaning and Finishing](#)

2.2 Federal Standard:³

[Fed. Std. No. 123 Marking for Shipment \(Civil Agencies\)](#)

2.3 Military Standard:³

[MIL-STD-129 Marking for Shipment and Storage](#)

2.4 ANSI/ASME Standard:⁴

[B1.20 Pipe Threads](#)

3. Terminology

3.1 Definitions of Terms Specific to This Standard:

3.1.1 *manufacturer, n*—the entity that casts the pipe and fittings covered by this standard.

4. Materials and Manufacture

4.1 The pipe and fittings shall be iron castings suitable for installation and service for sanitary, storm drain, waste, and vent piping applications. The pipe and fittings shall meet all applicable requirements and tests given in this specification.

4.2 The castings shall be made of cast iron, produced by an established commercial method that provides control over chemical and physical properties. Cast iron is a generic term for a series of alloys as defined in Terminology [A644](#) and includes gray iron as well as ductile iron. The castings shall be sound, true to pattern, and of compact close grain that permits drilling and cutting by ordinary methods. The interior surface shall be reasonably smooth and free from defects that would make the castings unfit for the use for which they are intended.

4.3 To minimize the possibility of introducing radioactive material to a melting operation, ferrous scrap, pig iron, and any recycled ferrous material shall be ~~screened~~ screened, by the manufacturer, for radioactivity with ~~suitable~~ detection devices operated in accordance with the detection manufacturer's instructions. ~~Written operating~~ operating, calibration, and maintenance procedures for the detection equipment shall be provided to the purchaser for review when requested. Records shall be maintained by load of these tests for a period of seven years.

4.3.1 Only radiation devices designed specifically for the purpose of screening ferrous material shipments shall be used for the purpose of conforming to this requirement. Hand held radiation detectors (Geiger counters) are not appropriate and shall not be used for the purpose of conforming to this requirement.

4.3.2 Material that is found contaminated with radioactivity shall not be used to produce products covered by this specification.

4.3.3 Analysis of castings after the time of production shall not be used to determine compliance to this specification.

² For referenced ASTM standards, visit the ASTM website, www.astm.org, or contact ASTM Customer Service at service@astm.org. For *Annual Book of ASTM Standards* volume information, refer to the standard's Document Summary page on the ASTM website.

³ Available from Standardization Documents Order Desk, DODSSP, Bldg. 4, Section D, 700 Robbins Ave., Philadelphia, PA 19111-5098, <http://www.dodssp.daps.mil>.

⁴ Available from American National Standards Institute (ANSI), 25 W. 43rd St., 4th Floor, New York, NY 10036, <http://www.ansi.org>.

4.4 Foundries manufacturing products to this specification shall comply to all local, provincial, state, and national safety laws and regulations and to the requirements of Practice E2349.

4.5 Pipe and fittings shall not be patched, filled, or welded to correct cosmetic or material defects that occur during the course of manufacturing.

5. Mechanical Properties

5.1 *Mechanical Tests for Gray Iron*—The manufacturer shall perform tests to determine mechanical properties of the gray iron used in the manufacture of gray iron soil pipe and fittings. Tension test specimens shall be employed. The manufacturer shall maintain a record of mechanical tests for a minimum of 7 years.

5.1.1 *Tensile Strength Test*—The tensile strength shall be not less than 21 000 psi (145 MPa).

5.1.2 Tension test reports shall include breaking load of test bars, machined diameter of test bar, and calculated tensile strength.

5.1.3 Analysis of castings or test bars after the time of production shall not be used as evidence of compliance to this specification.

6. Chemical Test for Gray Iron

6.1 The manufacturer shall perform tests to determine the significant chemical constituents of the gray iron used in the manufacture of gray iron soil pipe and fittings. Analysis shall be performed at the minimum of once per lot as defined in this specification. The manufacturer shall maintain a record of chemical tests performed for a minimum of 7 years. The test results shall conform to the following requirements as to chemical composition:

Phosphorous (P)	0.38 % Maximum
Sulfur (S)	0.15 % Maximum
Chromium (Cr)	0.50 % Maximum
Titanium (Ti)	0.10 % Maximum
Aluminum (Al)	0.50 % Maximum
Lead (Pb)	0.015 % Maximum
Carbon Equivalent	4.10 % Minimum by mass
Note: Carbon equivalent for gray iron = %C+%Si/3+%P/3	

6.1.1 Chemical tests shall be performed at the time of production of the castings covered by this specification.

6.1.2 Analysis of castings after the time of production shall not be used as evidence of compliance to this specification.

7. Dimensions and Permissible Variations

7.1 *Pipe:*

7.1.1 Single-hub pipe shall have a hub at one end and a spigot at the other. Double-hub pipe shall have a hub at each end. Hubs shall have lead grooves. The inner end of hub shall be either with or without a centering recess, all combinations of which shall make a satisfactory leakproof joint. Hub and barrel shall be cast in one piece (see Fig. 1).

7.1.2 Single-hub pipe shall be of 2½-ft (0.75-m), 3½-ft (1.00-m), 5-ft (1.5-m), and 10-ft (3.0-m) nominal laying lengths. The laying length shall be as shown in Table 1 and shall be within the tolerances on laying length specified in Table 2. Double-hub pipe shall be of the same overall length as single-hub pipe of the same size. Its laying length shall be 5 ft minus the two telescoping lengths (dimension Y), or 10 ft minus the telescoping length (dimension Y). Other dimensions shall be as specified in Table 1 as applicable, and be within the tolerances specified in Table 2. The dimensions shall apply to pipe before any coating is applied.

7.1.3 Pipe shall be straight to the extent that any deflections in the barrel of a 2½-ft (0.75-m), 3½-ft (1.00-m), and 5-ft (1.5-m) length of pipe shall not exceed ¼ in. (6.4 mm) for sizes 4 in. (102 mm) and larger, and shall not exceed ⅕ in. (7.9 mm) for smaller sizes; for 10-ft lengths, deflections in the barrel shall not exceed ½ in. (12.7 mm) for sizes 4 in. and larger, nor exceed ⅝ in. (15.9 mm) for smaller sizes.

7.2 *Fittings:*

7.2.1 *Dimensions of Fittings*—All fittings shall conform to the dimensions specified for hub and spigot ends in Table 1 and Table 2, as applicable. Fittings of the patterns specified in this specification shall conform to the applicable dimensions in Tables 3-37 inclusive, and to the tolerances in Table 2. Other patterns (Note 1) shall conform to Table 1, as applicable, for hub and spigot

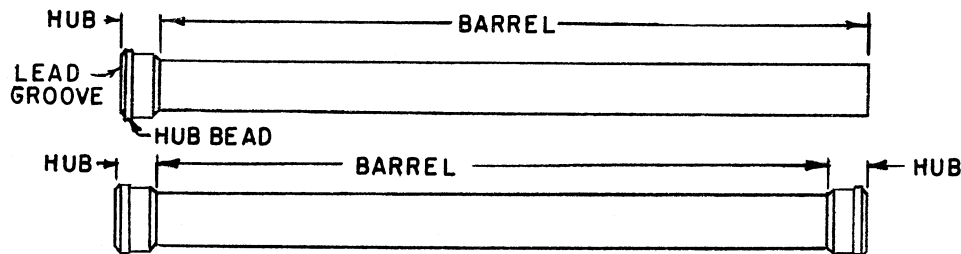
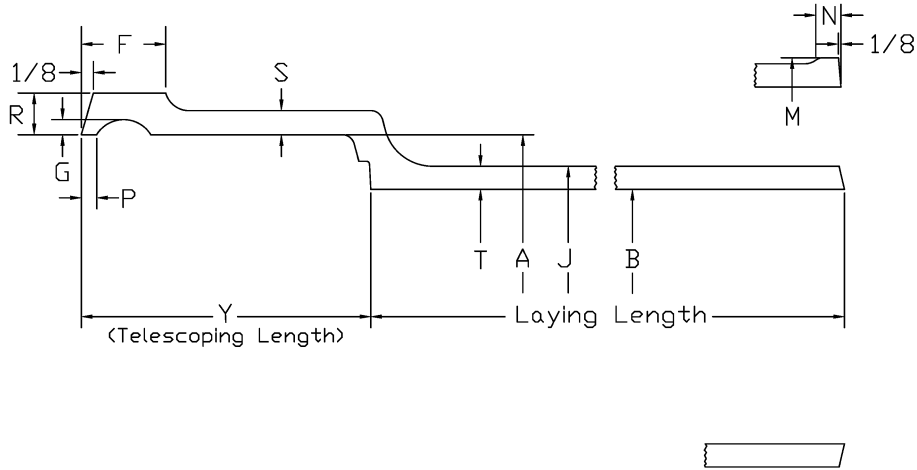

FIG. 1 Single-Hub and Double-Hub Cast Iron Soil Pipe Laying Lengths

TABLE 1 Dimensions of Hubs, Spigots, and Barrels for Extra-Heavy and Service Cast Iron Soil Pipe and Fittings, in.

NOTE 1—1 in. = 25.4 mm; 1 ft = 0.3 m throughout tables.



Service Cast Iron Soil Pipe:

Size ^A Availability ^B	Inside Diameter of Hub ^B	Outside Diameter of Barrel ^C	Telescoping Length ^C	Inside Diameter of Barrel ^C	Thickness of Barrel ^C	
	A	J	Y	B	T	
					Nom	Min
20	2.94 [74.68]	2.30 [58.42]	2.50 [63.5]	1.96 [49.78]	0.17 [4.32]	0.14 [3.56]
30	3.94 [100.08]	3.30 [83.82]	2.75 [69.85]	2.96 [75.18]	0.17 [4.32]	0.14 [3.56]
40	4.94 [125.48]	4.30 [109.22]	3.00 [76.2]	3.94 [100.08]	0.18 [4.57]	0.15 [3.81]
50	5.94 [150.88]	5.30 [134.62]	3.00 [76.2]	4.94 [125.48]	0.18 [4.57]	0.15 [3.81]
60	6.94 [176.28]	6.30 [160.02]	3.00 [76.2]	5.94 [150.88]	0.18 [4.57]	0.15 [3.81]
80	9.25 [234.95]	8.38 [212.85]	3.50 [88.9]	7.94 [201.68]	0.23 [5.84]	0.17 [4.32]
100	11.38 [289.05]	10.50 [266.70]	3.50 [88.9]	9.94 [252.48]	0.28 [6.86]	0.22 [5.59]
120	13.50 [342.9]	12.50 [317.5]	4.25 [107.95]	11.94 [303.28]	0.28 [6.86]	0.22 [5.59]
150	16.95 [430.53]	15.88 [403.35]	4.25 [107.95]	15.16 [385.06]	0.36 [9.14]	0.30 [7.62]

Size ^A	Thickness of Hub		Width of Hub Bead ^C	Distance from Lead Groove to End, Pipe and Fittings ^B	Depth of Lead Groove	
	Hub Body	Over Bead			G (min)	
	S (min)	R (min)	F (min)	P		
2	0.13 [3.30]	0.34 [8.64]	0.75 (0.63) [19.05] (16.00)	0.22 [5.59]	0.10 [2.54]	0.19 [4.83]
3	0.16 [4.06]	0.37 [9.40]	0.81 (0.63) [20.57] (16.00)	0.22 [5.59]	0.10 [2.54]	0.19 [4.83]
4	0.16 [4.06]	0.37 [9.40]	0.88 (0.63) [22.35] (16.00)	0.22 [5.59]	0.10 [2.54]	0.19 [4.83]
5	0.16 [4.06]	0.37 [9.40]	0.88 (0.63) [22.35] (16.00)	0.22 [5.59]	0.10 [2.54]	0.19 [4.83]
6	0.18 [4.57]	0.37 [9.40]	0.88 (0.63) [22.35] (16.00)	0.22 [5.59]	0.10 [2.54]	0.19 [4.83]
8	0.19 [4.83]	0.44 [11.26]	1.19 (1.06) [30.23] (26.92)	0.38 [9.65]	0.15 [3.81]	0.22 [5.59]
10	0.27 [6.86]	0.53 [13.46]	1.19 (1.06) [30.23] (26.92)	0.38 [9.65]	0.15 [3.81]	0.22 [5.59]
12	0.27 [6.86]	0.53 [13.46]	1.44 (1.31) [36.58] (33.27)	0.47 [11.94]	0.15 [3.81]	0.22 [5.59]
15	0.30 [7.62]	0.58 [14.73]	1.44 (1.31) [36.58] (33.27)	0.47 [11.94]	0.15 [3.81]	0.22 [5.59]

Extra-Heavy Cast Iron Soil Pipe and Fittings:

Size ^A Availability	Inside Diameter of Hub ^B	Outside Diameter of Barrel ^B	Telescoping Length ^B	Inside Diameter of Barrel ^B	Thickness of Barrel ^B	
	A	J	Y	B	T	
					Nom	Min
2*	3.06 [77.72]	2.38 [60.45]	2.50 [63.5]	2.00 [50.8]	0.19 [4.83]	0.16 [4.06]
3*	4.19 [106.43]	3.50 [88.9]	2.75 [69.85]	3.00 [76.2]	0.25 [6.35]	0.22 [5.59]
4*	5.19 [131.83]	4.50 [114.3]	3.00 [76.2]	4.00 [101.6]	0.25 [6.35]	0.22 [5.59]
5*	6.19 [157.23]	5.50 [139.7]	3.00 [76.2]	5.00 [127]	0.25 [6.35]	0.22 [5.59]
6*	7.19 [182.63]	6.50 [165.1]	3.00 [76.2]	6.00 [152.4]	0.25 [6.35]	0.22 [5.59]
8*	9.50 [241.30]	8.62 [218.5]	3.50 [88.9]	8.00 [203.2]	0.31 [7.87]	0.25 [6.35]
10*	11.62 [295.15]	10.75 [273.05]	3.50 [88.9]	10.00 [254]	0.37 [9.40]	0.31 [7.87]

TABLE 1 *Continued*

Extra-Heavy Cast Iron Soil Pipe and Fittings:

Size ^A	Availability	Inside Diameter of Hub ^B	Outside Diameter of Barrel ^B	Telescoping Length ^B	Inside Diameter of Barrel ^B	Thickness of Barrel ^B	
		A	J	Y	B	Nom	Min
12*		13.75 [349.25]	12.75 [323.85]	4.25 [107.95]	12.00 [304.8]	0.37 [9.40]	0.31 [7.87]
15*		16.95 [430.53]	15.88 [403.35]	4.25 [107.95]	15.00 [381]	0.44 [11.18]	0.38 [9.65]
Size ^A	Thickness of Hub		Width of Hub Bead ^{B,D}	Distance from Lead Groove to End, Pipe and Fittings ^B	Depth of Lead Groove		
	Hub Body	Over Bead			G (min)	G (max)	
	S (min)	R (min)	F	P	G (min)	G (max)	
2	0.18 [4.57]	0.37 [9.40]	0.75 [19.05]	0.22 [5.59]	0.10 [2.54]	0.19 [4.83]	
3	0.25 [6.35]	0.43 [10.92]	0.81 [20.57]	0.22 [5.59]	0.10 [2.54]	0.19 [4.83]	
4	0.25 [6.35]	0.43 [10.92]	0.88 [22.35]	0.22 [5.59]	0.10 [2.54]	0.19 [4.83]	
5	0.25 [6.35]	0.43 [10.92]	0.88 [22.35]	0.22 [5.59]	0.10 [2.54]	0.19 [4.83]	
6	0.25 [6.35]	0.43 [10.92]	0.88 [22.35]	0.22 [5.59]	0.10 [2.54]	0.19 [4.83]	
8	0.34 [8.64]	0.59 [14.99]	1.19 [30.23]	0.38 [9.65]	0.15 [3.81]	0.22 [5.59]	
10	0.40 [10.16]	0.65 [16.51]	1.19 [30.23]	0.38 [9.65]	0.15 [3.81]	0.22 [5.59]	
12	0.40 [10.16]	0.65 [16.51]	1.44 [36.54]	0.47 [11.94]	0.15 [3.81]	0.22 [5.59]	
15	0.46 [11.68]	0.71 [18.03]	1.44 [36.54]	0.47 [11.94]	0.15 [3.81]	0.22 [5.59]	

^A Nominal inside diameter.

* Indicates this item is made in extra heavy.

^B For tolerances, see [Table 2](#).

^C Hub ends and spigot ends shall be permitted to be made with or without draft.

O Indicates this item is made in service weight.

^D Hub ends and spigot ends can be made with or without draft.



<https://standards.iteh.ai>

dimensions, and for wall thickness throughout, and to dimension *R*, [Tables 15-17](#), for the minimum radius of any drainage inlets that such fittings shall be permitted to provide. All fittings shall have spigot ends of sufficient length to provide adequate room for making joints. All dimensions given in this specification shall apply to fittings before any coating is applied.

NOTE 1—Such as, for example, fittings known in the trade as “specials,” when designated as being in conformity with this specification.

7.2.2 *Water Seal and Traps*—Traps shall have water seals as follows:

Trap Size, in. (mm)	Minimum Water seal, in. (mm)
2 (50)	2 (50)
3 to 6 (75 to 150), incl	2½ (64)
8 to 12 (200 to 300), incl	3 (75)

7.2.3 *Ends of Fittings*—Hubs shall have lead grooves. The inner end of hub shall be permitted to be either with or without a centering recess, all combinations of which shall enable the installer to make a satisfactory joint. Tapped openings shall conform to [7.2.4](#). It is permissible to increase the wall thickness on the inside surface of fittings having one or more plain ends. The increased thickness shall not reduce the minimum *B* dimension in [Table 1](#) in excess of 0.10 in. for sizes 8 in. and smaller, and 0.15 in. for 10 in. and larger, and shall not extend more than 4¼ in. from the plain end. The increased thickness shall be tapered and offer no obstruction to flow. Inside diameters complying with service or extra heavy inside diameters shall be permitted on 12 and 15-in. sizes only.

7.2.4 *Pipe Threads*—Screw plugs and tapped openings in fittings shall have American Standard taper pipe threads. The threads shall be in accordance with ANSI/ASME B1.20 of the current issue.

7.2.5 Internal threads shall be chamfered on the entering end approximately to the major diameter of the thread, at an angle of approximately 45° with the axis of the thread, and the entering end of external threads shall be similarly chamfered approximately to be minor diameter of the thread, for easy entrance in making a joint and for protection of the thread. The chamfer shall be concentric with the thread and shall be included in measurements of thread length.

8. Methods of Specifying Fittings

8.1 *Method of Specifying Sizes of Fittings of More than One Size*—The sizes are designated by the order of listing, as follows:

8.1.1 Branch and tapped fittings:

8.1.1.1 Size of run ([Note 2](#)), and

8.1.1.2 Size of branch.

8.1.2 Reducers, increasers, and offset fittings:

TABLE 2 Dimensional Tolerances for Extra-Heavy and Service Cast Iron Soil Pipe and Fittings, in.

NOTE 1—1 in. = 25.4 mm.

NOTE 2—The tolerances set forth in Table 2 are intended for pipe and fittings designed for use with lead and oakum joints; however, these same tolerances shall apply to pipe and fittings designed for use with a compression type gasket joint.

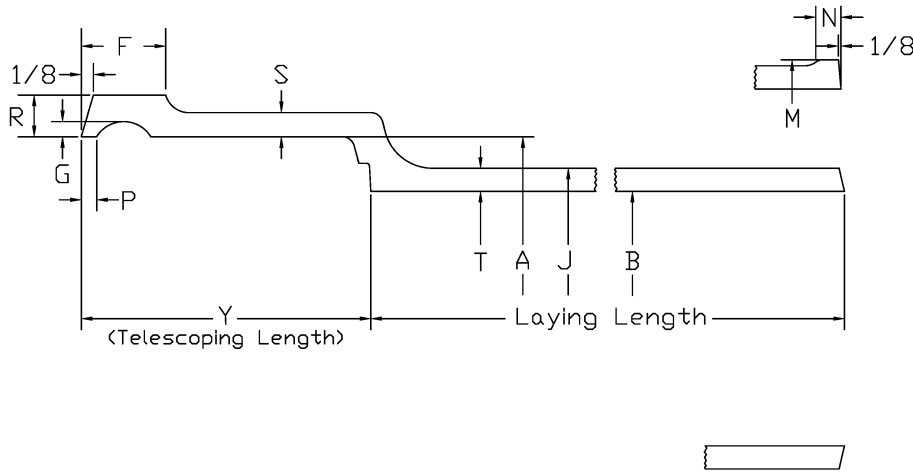

Size ^A	Inside Diameter of Hub	Outside Diameter of Barrel	Inside Diameter of Barrel	Telescoping Length	Laying Length		
	A'	J	B	Y	Pipe, 2½, 3½, 5-ft Lengths	Pipe, 10-ft Lengths	Fittings Regular Extra Long ^B
2	±0.06 [1.52]	±0.09 [±2.29]	±0.09 [±2.29]	±0.06 [±1.52]	±¼ [±6.35]	±½ [±12.7]	±⅛ [±3.18] ±⅛ [±1.59]
3	±0.09 [2.29] -0.06 [1.52]	±0.09 [±2.29]	±0.09 [±2.29]	±0.06 [±1.52]	±¼ [±6.35]	±½ [±12.7]	±⅛ [±3.18] ±⅛ [±1.59]
4	±0.09 [2.29] -0.06 [1.52]	±0.09 [±2.29]	±0.09 [±2.29]	±0.06 [±1.52]	±¼ [±6.35]	±½ [±12.7]	±⅛ [±3.18] ±⅛ [±1.59]
5	+0.09 [2.29] -0.06 [1.52]	±0.09 [±2.29]	±0.09 [±2.29]	±0.06 [±1.52]	±⅝ [±7.94]	±⅝ [±15.88]	±⅜ [±4.76] ±⅜ [±2.38]
6	+0.09 [2.29] -0.06 [1.52]	±0.09 [±2.29]	±0.09 [±2.29]	±0.06 [±1.52]	±⅝ [±7.94]	±⅝ [±15.88]	±⅜ [±4.76] ±⅜ [±2.38]
8	±0.13 [3.30]	±0.13 [±3.30]	±0.13 [±3.30]	±0.13 [±3.30]	±⅝ [±7.94]	±⅝ [±15.88]	±⅜ [±4.76] ±⅜ [±2.38]
10	±0.13 [3.30]	±0.13 [±3.30]	±0.13 [±3.30]	±0.13 [±3.30]	±¾ [±9.53]	±¾ [±19.05]	±¼ [±6.35] ±⅛ [±3.18]
12	±0.13 [3.30]	±0.19 [±4.83]	±0.19 [±4.83]	±0.19 [±4.83]	±¾ [±9.53]	±¾ [±19.05]	±¼ [±6.35] ±⅛ [±3.18]
15	±0.13 [3.30]	±0.19 [±4.83]	±0.19 [±4.83]	±0.19 [±4.83]	±¾ [±9.53]	±¾ [±19.05]	±¼ [±6.35] ±⅛ [±3.18]
		Size				Distance from Lead Groove to End, Pipe and Fittings	
						P	
		2				±0.09 [±1.52]	
		3				±0.09 [±1.52]	
		4				±0.09 [±1.52]	
		5				±0.09 [±1.52]	
		6				±0.09 [±1.52]	
		8				±0.09 [±1.52]	
		10				±0.09 [±1.52]	
		12				±0.11 [±2.79]	
		15				±0.11 [±2.79]	

^A Nominal inside diameter.

^B These tolerances apply to each foot of extra-long fittings in excess of regular laying lengths specified in this specification.

- 8.1.2.1 Size of inlet or run (Note 2),
- 8.1.2.2 Size of outlet or offset distance,
- 8.1.2.3 Length, if supplied in more than one length.

NOTE 2—The run is that portion of the fitting that forms part of the main drain, waste, or vent line. The spigot end is ordinarily the outlet.

8.2 Method of Specifying Hand of Fittings with Side Inlets and Outlets—When placed in the position described below, if the side inlet or outlet appears on the right, it is a right-hand fitting; if on the left, it is a left-hand fitting.

8.2.1 Bends and Offsets—Place the fitting with hub facing toward the observer and the spigot end lower than the hub.

TABLE 3 Dimensions of One-Quarter Bends

NOTE 1—1 in. = 25.4 mm.

NOTE 2—Dimensions *D* and *X* are laying lengths.

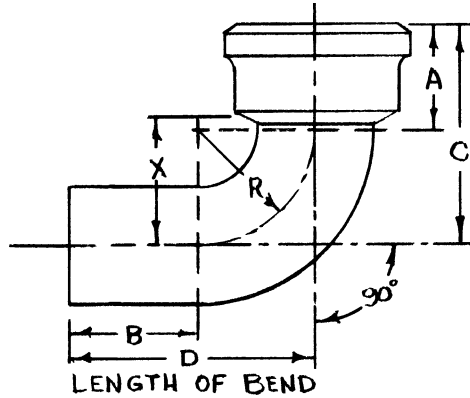

Size, in., Availability ^A	Dimensions in in. ^B					
	A	B	C	D	R	X
2"O	2¾ [70]	3 [76]	5¾ [146]	6 [152]	3 [76]	3¼ [83]
3"O	3¼ [83]	3½ [89]	6¾ [171]	7 [178]	3½ [89]	4 [102]
4"O	3½ [89]	4 [102]	7½ [191]	8 [203]	4 [102]	4½ [114]
5"O	3½ [89]	4 [102]	8 [203]	8 [203]	4½ [114]	5 [127]
6"O	3½ [89]	4 [102]	8½ [216]	9 [229]	5 [127]	5½ [140]
8"O	4½ [105]	5½ [140]	10½ [257]	11½ [292]	6 [152]	6¾ [168]
10"O	4½ [105]	5½ [140]	11½ [283]	12½ [318]	7 [178]	7¾ [194]
12"O	5 [127]	7 [178]	13 [330]	15 [381]	8 [203]	8¾ [222]
15"O	5 [127]	7 [178]	14½ [368]	16½ [419]	9½ [241]	10¼ [260]

^A * indicates this item is made in extra heavy.

O indicates this item is made in service weight.

^B For details of hubs and spigots, see Table 1.

Document Preview

8.2.2 *Branch Fittings*—Place the branch toward the observer and the spigot end lower than the hub.

8.2.3 *Traps*—Place in the position in which the trap is installed, with the hub toward the observer.

8.2.4 The fittings shown in Fig. 2 have right-hand inlet or cleanout. Left-hand fittings have these openings on the side opposite to that shown. For details of side inlets, see Fig. 2.

9. Coating

9.1 The pipe and fittings shall be uniformly coated with a material suitable for the purpose, that is adherent, not brittle, and without a tendency to scale. The coating shall not contain asbestos above current MSDS reportable levels. Material safety data sheets shall be furnished by the coating manufacturer when requested. The coating shall be evenly and smoothly applied to all surfaces, except in threaded openings.

9.2 Pipe and fittings shall not be coated with paint containing lead which exceeds levels above 0.06 % (600 ppm).

9.3 The manufacturer shall annually prepare and submit samples to a qualified laboratory for test in accordance with Practice E1645.

9.4 Pipe and fittings shall not be coated with paint containing levels of volatile organic hazardous air pollutants (VOHAPs) which exceed levels of 2.6 pounds (0.31 kilograms per liter) of VOHAPs per gallon of solids. Reference ASTM D3960-05.

9.5 The manufacturer shall prepare and submit samples when changing sources of supply or the coating manufacturer changes formulations for the coating.

9.6 Records shall be maintained for a period of seven years.

9.7 Copies of the coating test shall be furnished when requested.

10. Sampling

10.1 Chemical and mechanical tests shall be made regularly and at sufficiently close intervals for adequate determinations of the significant chemical constituents and properties of the cast iron. A specimen taken from a finished product often does not produce the same results as a specimen formed by the method used for sample preparation and is not acceptable for the purpose

TABLE 4 Dimensions of Long One-Quarter Bends

NOTE 1—1 in. = 25.4 mm.

NOTE 2—Dimensions *D* and *X* are laying lengths.

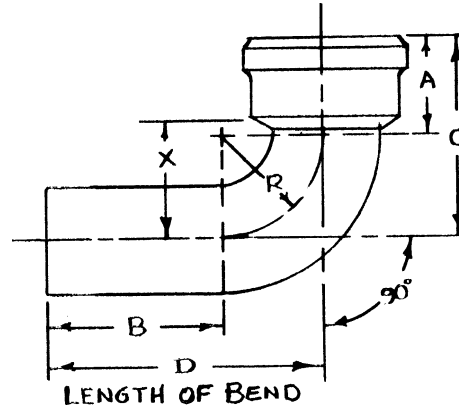

Size, in., Availability ^A	Dimensions in in. ^B					
	A	B	C	D	R	X
2 by 12°O	2¾ [76]	9 [229]	5¾ [146]	12 [305]	3 [76]	3¼ [83]
2 by 18°O	2¾ [76]	15 [381]	5¾ [146]	18 [457]	3 [76]	3¼ [83]
2 by 24°O	2¾ [76]	21 [533]	5¾ [146]	24 [610]	3 [76]	3¼ [83]
3 by 12°O	3¼ [83]	8½ [216]	6¾ [171]	12 [305]	3½ [89]	4 [102]
3 by 18°O	3¼ [83]	14½ [368]	6¾ [171]	18 [457]	3½ [89]	4 [102]
3 by 24°O	3¼ [83]	20½ [521]	6¾ [171]	24 [610]	3½ [89]	4 [102]
4 by 12°O	3½ [89]	8 [203]	7½ [191]	12 [305]	4 [102]	4½ [114]
4 by 18°O	3½ [89]	14 [356]	7½ [191]	18 [457]	4 [102]	4½ [114]
4 by 24°O	3½ [89]	20 [508]	7½ [191]	24 [610]	4 [102]	4½ [114]

^A * indicates this item is made in extra heavy.
 O indicates this item is made in service weight.
^B For details of hubs and spigots, see Table 1.

TABLE 5 Dimensions of Long Low-Hub One-Quarter Bends

NOTE 1—1 in. = 25.4 mm.

NOTE 2—Dimensions *D* and *X* are laying lengths.

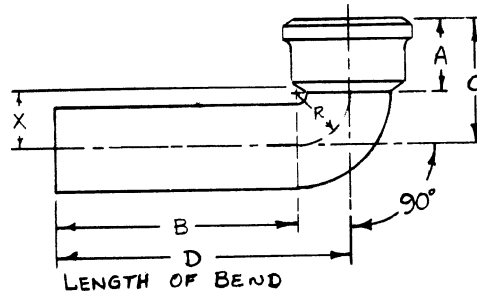

Size, in., Availability ^A	Dimensions in in. ^B					
	A	B	C	D	R	X
4 by 12O	3 [76]	9¼ [235]	5¾ [146]	12 [305]	2¾ [70]	2¾ [70]
4 by 14O	3 [76]	11¼ [286]	5¾ [146]	14 [356]	2¾ [70]	2¾ [70]
4 by 16O	3 [76]	13¼ [337]	5¾ [146]	16 [406]	2¾ [70]	2¾ [70]
4 by 18O	3 [76]	15¼ [387]	5¾ [146]	18 [457]	2¾ [70]	2¾ [70]

^A O indicates this item is made in service weight.
^B For details of hubs and spigots, see Table 1.

of testing to this standard. Records of chemical analysis shall be maintained by the manufacturer by lot. Copies of these analyses shall be furnished to the purchaser when requested.

10.2 A lot shall consist of one of the following:

10.2.1 All the metal poured from a single heating in a batch type furnace,

TABLE 6 Dimensions of One-Quarter Bends with Low Heel Inlet

NOTE 1—1 in. = 25.4 mm.

NOTE 2—Dimensions *D*, *X*, and *X'* are laying lengths

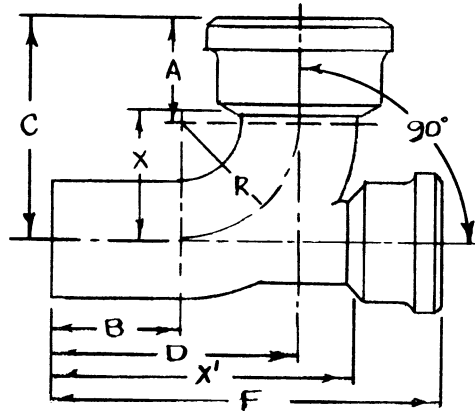

Size, in., Availability ^A	Dimensions in in. ^B							
	A	B	C	D	F	R	X	X'
3 by 2O	3¼ [83]	3½ [89]	6¾ [172]	7 [178]	11½ [292]	3½ [89]	4 [102]	9 [229]
4 by 2O	3½ [89]	4 [102]	7½ [191]	8 [203]	13 [330]	4 [102]	4½ [114]	10½ [267]

^A O indicates this item is made in service weight.

^B For details of hubs and spigots, see Table 1.

TABLE 7 Dimensions of Quarter Bends with High Heel Inlet

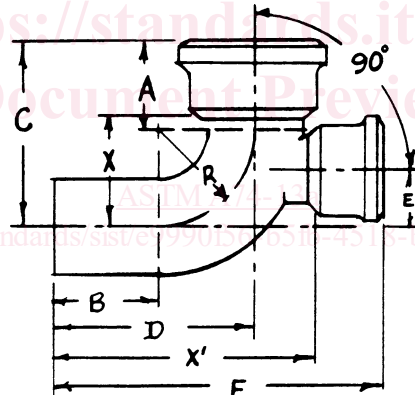

Size, in., Availability ^A	Dimensions in in. ^B								
	A	B	C	D	E	F	R	X	X'
4 by 2*O	3½ [89]	4 [102]	7½ [191]	8 [203]	2¾ [70]	13 [330]	4 [102]	4½ [114]	10½ [267]

^A * indicates this item is made in extra heavy.

O indicates this item is made in service weight.

^B For details of hubs and spigots, see Table 1.

10.2.2 All the metal from two or more batch type melting furnaces poured into a single ladle or a single casting.

10.2.3 All the metal poured from a continuous melting furnace for a given period of time between changes in charge, processing conditions, aim-for chemistry, or 4 hours, whichever is the shorter period.

11. Test Methods

11.1 Gray Iron:

11.1.1 *Tensile Strength Test*—Test bars shall be cast in accordance with the requirements of Specification A48/A48M. See Fig. 3 (Tension Test Specimens) for the machined test bar dimensions and as cast test bar dimensions. The tensile strength shall be determined in accordance with Test Methods E8.

11.1.2 Tension test reports shall include breaking load of test bars, machined diameter of test bar, and calculated tensile strength.

TABLE 8 Dimensions of Short and Long Sweep Bends

NOTE 1—1 in. = 25.4 mm.

NOTE 2—Dimensions *D* and *X* are laying lengths.

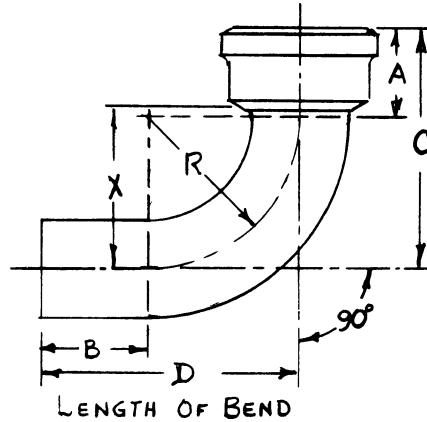

Short Sweep Bends:

Size, in.	Dimensions in in. ^A					
	A	B	C	D	R	X
2°O	2¾ [70]	3 [76]	7¾ [197]	8 [203]	5 [127]	5¼ [133]
3°O	3¼ [83]	3½ [89]	8¾ [222]	9 [229]	5½ [140]	6 [152]
4°O	3½ [89]	4 [102]	9½ [241]	10 [254]	6 [152]	6½ [165]
5°O	3½ [89]	4 [102]	10 [254]	10½ [267]	6½ [165]	7 [178]
6°O	3½ [89]	4 [102]	10½ [267]	11 [279]	7 [178]	7½ [191]
8°O	4¼ [105]	5½ [140]	12½ [308]	13½ [343]	8 [203]	8½ [219]
10°O	4½ [105]	5½ [140]	13½ [333]	14½ [368]	9 [229]	9½ [244]
12°O	5 [127]	7 [178]	15 [381]	17 [432]	10 [254]	10¾ [273]
15°O	5 [127]	7 [178]	16½ [419]	18½ [470]	11½ [292]	12¼ [311]

^A For details of hubs and spigots, see Table 1.

Long Sweep Bends:

Size, in., Availability ^A	Dimensions in in. ^B					
	A	B	C	D	R	X
2°O	2¾ [70]	3 [76]	10¾ [273]	11 [279]	8 [203]	8¼ [210]
3°O	3¼ [83]	3½ [89]	11¾ [298]	12 [305]	8½ [216]	9 [229]
4°O	3½ [89]	4 [102]	12½ [318]	13 [330]	9 [229]	9½ [241]
5°O	3½ [89]	4 [102]	13 [330]	13½ [343]	9½ [241]	10 [254]
6°O	3½ [89]	4 [102]	13½ [343]	14 [356]	10 [254]	10½ [267]
8°O	4¼ [105]	5½ [140]	15½ [384]	16½ [419]	11 [279]	11½ [295]
10°O	4½ [105]	5½ [140]	16½ [410]	17½ [445]	12 [305]	12½ [321]
12°O	5 [127]	7 [178]	18 [457]	20 [508]	13 [330]	13¾ [349]
15°O	5 [127]	7 [178]	19½ [495]	21½ [546]	14½ [368]	15¼ [387]

^A * indicates this item is made in extra heavy.

O indicates this item is made in service weight.

^B For details of hubs and spigots, see Table 1.

12. Inspection

12.1 *Inspection and Test by the Manufacturer*—Pipe and fittings shall be inspected to verify compliance with this specification. The manufacturer shall maintain a record of all inspections.

12.2 *Pipe Inspection*—At regular intervals (not to exceed 12 h) during the course of production, sample pieces of each size of pipe or pipes being produced shall be selected randomly for inspection. Each pipe selected shall be measured by suitable gages and all dimensions detailed in Tables 1 and 2 of this specification verified to comply with the requirements of this specification. The inspection records shall be maintained by the manufacturer for a period of seven years.

12.3 *Fitting Inspection*—At regular intervals (not to exceed 12 h) during the course of production, sample pieces of each size and configuration of fitting being produced shall be selected randomly for inspection. Each fitting selected shall be measured by suitable gages to verify that the laying length (as detailed in Tables 3-37), and all applicable dimensions detailed in Tables 1 and 2 of this specification comply with the requirements of this specification. The inspection records shall be maintained by the manufacturer for a period of seven years.

TABLE 9 Dimensions of Reducing Long Sweep Bends

NOTE 1—1 in. = 25.4 mm.

NOTE 2—Dimensions *D* and *X* are laying lengths.

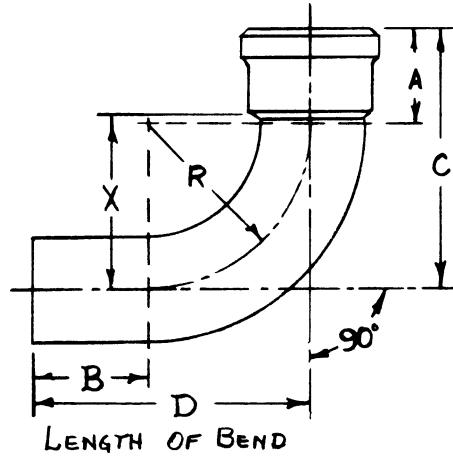

Size, in., Availability ^A	Dimensions in in. ^B					
	A	B	C'	D	R	X
3 by 2"O	3 [76]	3½ [89]	11½ [292]	12 [305]	8½ [216]	9 [229]
4 by 3"O	3¾ [83]	4 [102]	12¼ [311]	13 [330]	9 [229]	9½ [241]

^A * indicates this item is made in extra heavy.

O indicates this item is made in service weight.

^B For details of hubs and spigots, see Table 1.

iTeh Standards
(<https://standards.itih.ai>)
Document Preview

12.4 *Marking Inspection*—Inspection shall include verification that the markings on pipe and fittings comply with Section 14 of this specification.

13. Certification

13.1 Upon request, the purchaser, design professional, or the administrative authority having jurisdiction where the products are being installed shall be furnished certification, by the manufacturer, stating samples representing each lot have been tested and inspected as indicated in this specification and the requirements have been met. If requested by the purchaser, design professional, or the administrative authority having jurisdiction where the products are being installed, certification shall be accompanied by test reports as prepared in accordance with the Sections 11 and 12 of this specification. Tension test reports shall include breaking load machined diameters of test bars and calculated tensile strength. Certification shall include the legal name and address of the manufacturer.

13.2 Third Party certifiers or inspectors shall utilize the procedures detailed in Annex A1 when conducting inspections at the manufacturing locations.

14. Product Marking

14.1 Each length of pipe and each fitting shall be plainly marked with the country of origin, the manufacturer's name or registered trademark by which the manufacturer can be readily identified after installation. The markings shall be adequate identification of the manufacturer of the pipe and fittings if it readily identified the manufacturer to the end user of the product. Other markings on pipes and fittings are permitted as long as such markings are not misleading with respect to the identification of the manufacturer by the end user. Each length of pipe and each fitting shall be plainly marked with letters to indicate the proper classification, as follows:

XH
SV

Extra Heavy
Service

The marking shall be cast, stenciled, or otherwise applied on the pipe so as to be clear and legible after installation. The marking shall be cast with raised letters on fittings and shall be clear and legible after installation and located away from the spigot end so as not to interfere with proper joining upon installation.

14.2 Each pipe shall be marked with the date of manufacture. The marking shall be stenciled on the pipe or otherwise applied to be clear and legible. The marking shall be a minimum of 3/4-in. size.

TABLE 10 Dimensions of One-Fifth and One-Sixth Bends

NOTE 1—1 in. = 25.4 mm.

NOTE 2—Dimensions *D* and *X* are laying lengths.

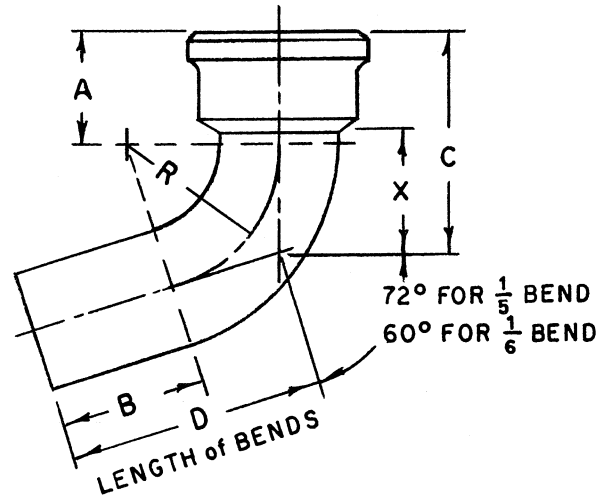

One-Fifth Bends:

Size, in. Availability ^A	Dimensions in in. ^B					
	A	B	C	D	R	X
3O	3¼ [83]	3½ [89]	5¼ [148]	6¼ [154]	3½ [89]	3¼ [78]
4O	3 ⅓ [85]	4 [102]	6⅞ [164]	6½ [176]	4 [102]	3⅞ [87]

^A O indicates this item is made in service weight.

^B For details of hubs and spigots, see Table 1.

One Sixth Bends:

Size, in., Availability ^A	Dimensions in in. ^B					
	A	B	C	D	R	X
2*O	2¾ [70]	3 [76]	4½ [114]	4¾ [121]	3 [76]	2 [51]
3*O	3¼ [83]	3½ [89]	5¼ [133]	5½ [140]	3½ [89]	2½ [64]
4*O	3½ [89]	4 [102]	5¼ [147]	6⅞ [160]	4 [102]	2¾ [71]
5*O	3½ [89]	4 [102]	6⅞ [156]	6⅞ [168]	4½ [114]	3⅞ [79]
6*O	3½ [89]	4 [102]	6⅞ [161]	6⅞ [175]	5 [127]	3⅞ [86]
8*O	4⅞ [105]	5½ [140]	7⅞ [194]	9 [229]	6 [152]	4⅞ [105]
10*O	4⅞ [105]	5½ [140]	8¼ [208]	9⅞ [243]	7 [179]	4⅞ [119]

^A For details of hubs and spigots, see Table 1.

^B * indicates this item is made in extra heavy.

O indicates this item is made in service weight.

15. Packaging and Package Marking

15.1 *Government Procurement*—Unless otherwise specified in the contract, the material shall be packaged in accordance with the supplier’s standard practice that will be acceptable to the carrier at lowest rates. Containers and packing shall comply with Uniform Freight Classification Rules⁵ or National Motor Freight Classification Rules.⁶ Marking for shipment of such material shall be in accordance with Fed. Std. No. 123 for civil agencies and MIL-STD-129 for military agencies.

16. Keywords

16.1 cast iron; fitting; hub and spigot pipe; pipe; soil pipe

⁵ Available from The Uniform Classification Commission, Room 1106, 222 S. Riverside Plaza, Chicago, IL 60606.

⁶ Available from National Motor Freight Traffic Association (NMFTA), 1001 N. Fairfax St., Alexandria, VA 22314, <http://www.nmfta.org>.