



Designation: F2564 – 13

# Standard Specification for Design and Performance of a Light Sport Glider<sup>1</sup>

This standard is issued under the fixed designation F2564; the number immediately following the designation indicates the year of original adoption or, in the case of revision, the year of last revision. A number in parentheses indicates the year of last reapproval. A superscript epsilon ( $\epsilon$ ) indicates an editorial change since the last revision or reapproval.

## 1. Scope

1.1 This specification covers airworthiness requirements for the design of a powered or non-powered fixed wing light sport aircraft, a “glider.”

1.2 This specification is applicable to the design of a light sport aircraft glider as defined by regulations and limited to day VFR flight.

1.3 A glider for the purposes of this specification is defined as a heavier than air aircraft that remains airborne through the dynamic reaction of the air with a fixed wing and in which the ability to remain aloft in free flight does not depend on the propulsion from a power plant. A powered glider is defined for the purposes of this specification as a glider equipped with a power plant in which the flight characteristics are those of a glider when the power plant is not in operation.

1.4 The values in SI units are to be regarded as the standard. The values in parenthesis are for information only.

1.5 *This standard does not purport to address all of the safety concerns, if any, associated with its use. It is the responsibility of the user of this standard to establish appropriate safety and health practices and determine the applicability of regulatory requirements prior to use.*

## 2. Referenced Documents

### 2.1 ASTM Standards:<sup>2</sup>

[F2279 Practice for Quality Assurance in the Manufacture of Fixed Wing Light Sport Aircraft](#)

[F2295 Practice for Continued Operational Safety Monitoring of a Light Sport Aircraft](#)

[F2316 Specification for Airframe Emergency Parachutes](#)

[F2339 Practice for Design and Manufacture of Reciprocating Spark Ignition Engines for Light Sport Aircraft](#)

[F2840 Practice for Design and Manufacture of Electric Propulsion Units for Light Sport Aircraft](#)

<sup>1</sup> This specification is under the jurisdiction of ASTM Committee F37 on Light Sport Aircraft and is the direct responsibility of Subcommittee F37.10 on Glider.

Current edition approved May 1, 2013. Published June 2013. Originally approved in 2006. Last previous edition approved in 2011 as F2564 – 11. DOI: 10.1520/F2564-13.

<sup>2</sup> For referenced ASTM standards, visit the ASTM website, www.astm.org, or contact ASTM Customer Service at service@astm.org. For *Annual Book of ASTM Standards* volume information, refer to the standard's Document Summary page on the ASTM website.

### 2.2 Other Standards:

[CS-22 Subpart H Certification Specifications for Sailplanes and Powered Sailplanes<sup>3</sup>](#)

## 3. Terminology

### 3.1 Definitions:

3.1.1 *electric propulsion unit, EPU*—any electric motor and all associated devices used to provide thrust for an electric aircraft.

3.1.2 *energy storage device, ESD*—used to store energy as part of a Electric Propulsion Unit (EPU). Typical energy storage devices include but are not limited to batteries, fuel cells or capacitors.

3.1.3 *feathering*—a single action from the cockpit that repositions the propeller blades to low drag configuration when the engine is not operating.

3.1.4 *flaps*—any movable high lift device.

3.1.5 *maximum empty weight,  $W_E$  (kg)* —largest empty weight of the glider, including all operational equipment that is installed in the glider: weight of the airframe, powerplant, excluding energy storage device (ESD) for electric propulsion unit when removable, required equipment, optional and specific equipment, fixed ballast, full engine coolant and oil, hydraulic fluid, and the unusable fuel. Hence, the maximum empty weight equals maximum takeoff weight minus minimum useful load:  $W_E = W - W_U$ .

3.1.6 *minimum useful load,  $W_U$  (kg)*—where  $W_U = W - W_E$ .

3.1.7 The terms “engine” referring to internal combustion engines and “motor” referring to electric motors for propulsion are used interchangeably within this standard.

3.1.8 The term “engine idle” or “throttle closed” when in reference to electric propulsion units shall mean the minimum power or propeller rotational speed condition for the electric motor as defined without electronic braking of the propeller rotational speed.

### 3.2 Abbreviations:

3.2.1 *AOI*—Aircraft Operating Instructions

3.2.2 *AR*—Aspect Ratio =  $b^2/S$

<sup>3</sup> Available from European Aviation Safety Agency (EASA), Postfach 10 12 53, D-50452 Koeln, Germany, <http://www.easa.eu.int/home.php>.

- 3.2.3  $b$ —wing span (m)
- 3.2.4  $c$ —chord (m)
- 3.2.5  $CAS$ —calibrated air speed (m/s, kts)
- 3.2.6  $C_L$ —lift coefficient of the aircraft
- 3.2.7  $C_D$ —drag coefficient of the aircraft
- 3.2.8  $CG$ —center of gravity
- 3.2.9  $C_m$ —moment coefficient ( $C_m$  is with respect to  $c/4$  point, positive nose up)
- 3.2.10  $C_{MO}$ —zero lift moment coefficient
- 3.2.11  $C_n$ —normal coefficient
- 3.2.12  $g$ —acceleration as a result of gravity = 9.81 m/s<sup>2</sup>
- 3.2.13  $IAS$ —indicated air speed (m/s, kts)
- 3.2.14  $ICAO$ —International Civil Aviation Organization
- 3.2.15  $LSA$ —light sport aircraft
- 3.2.16  $n$ —load factor
- 3.2.17  $n_1$ —glider positive maneuvering limit load factor at  $V_A$
- 3.2.18  $n_2$ —glider positive maneuvering limit load factor at  $V_D$
- 3.2.19  $n_3$ —glider negative maneuvering limit load factor at  $V_A$
- 3.2.20  $n_4$ —glider negative maneuvering limit load factor at  $V_D$
- 3.2.21  $q$ —dynamic pressure = 0.004823  $V^2$  kg/m<sup>2</sup>, when  $V$  is in km/h
- 3.2.22  $S$ —wing area (m<sup>2</sup>)
- 3.2.23  $V$ —airspeed (m/s, kts)
- 3.2.24  $V_A$ —design maneuvering speed
- 3.2.25  $V_C$ —design cruising speed
- 3.2.26  $V_D$ —design diving speed
- 3.2.27  $V_{DF}$ —demonstrated flight diving speed
- 3.2.28  $V_F$ —design flap speed
- 3.2.29  $V_{FE}$ —maximum flap extended speed
- 3.2.30  $V_H$ —maximum speed in level flight with maximum continuous power (corrected for sea level standard conditions)
- 3.2.31  $V_{LO}$ —maximum speed for landing gear extended
- 3.2.32  $V_{NE}$ —never exceed speed
- 3.2.33  $V_S$ —stalling speed or minimum steady flight speed at which the aircraft is controllable (flaps retracted)
- 3.2.34  $V_{S1}$ —stalling speed, or minimum steady flight speed in a specific configuration
- 3.2.35  $V_{SO}$ —stalling speed or minimum steady flight speed at which the aircraft is controllable in the landing configuration
- 3.2.36  $V_R$ —ground gust speed
- 3.2.37  $V_T$ —maximum aerotow speed
- 3.2.38  $V_W$ —maximum winch tow speed
- 3.2.39  $V_Y$ —speed for best rate of climb
- 3.2.40  $W$ —maximum takeoff or maximum design weight (kg)

3.2.41  $W_E$ —maximum empty aircraft weight (kg)

3.2.42  $W_U$ —minimum useful load (kg)

3.2.43  $w$ —average design surface load (N/m<sup>2</sup>)

## 4. Flight

### 4.1 Proof of Compliance:

4.1.1 Each of the following requirements shall be met at the most critical weight and CG configuration. Unless otherwise specified, the speed range from stall to  $V_{DF}$  or the maximum allowable speed for the configuration being investigated shall be considered.

4.1.1.1  $V_{DF}$  shall be less than or equal to  $V_D$ .

4.1.1.2 If  $V_{DF}$  chosen is less than  $V_D$ ,  $V_{NE}$  must be less than or equal to 0.9  $V_{DF}$  and greater than or equal to 1.1  $V_C$ .

4.1.2 The following tolerances are acceptable during flight testing:

Weight	+5 %, -10 %
Weight, when critical	+5 %, -1 %
CG	±7 % of total travel

4.2 Compliance must be established for all configurations except as otherwise noted. In demonstrating compliance, the powerplant or propeller, if retractable, must be retracted, except as otherwise noted.

### 4.3 Load Distribution Limits:

4.3.1 The maximum weight shall be determined so that it is:

4.3.1.1 Not more than:

(1) The highest weight selected by the applicant, and

(2) The design maximum weight, which is the highest weight at which compliance with each applicable structural loading condition and all requirements for flight characteristics is shown.

4.3.1.2 Not less than:

(1) For a single-place glider not less than the empty weight of the glider, plus a weight of the occupant of 80 kg, plus the required minimum equipment, plus, for a powered glider, sufficient energy (fuel or other energy storage) for at least 30 min of flight at maximum continuous power.

(2) For a two-place glider not less than the empty weight of the glider, plus a weight of the occupants of 160 kg, plus the required minimum equipment, plus, for a powered glider, sufficient energy (fuel or other energy storage) for at least 30 min of flight at maximum continuous power.

4.3.2 The design empty weight shall be specified by the manufacturer.

### 4.3.3 Empty Weight and Center of Gravity Range:

4.3.3.1 The CG range within which the glider can be safely operated must be specified by the manufacturer.

4.3.3.2 The empty weight, corresponding CG, most forward, and most rearward CG shall be determined with fixed ballast and required minimum equipment.

4.3.3.3 The CG range must not be less than that which corresponds to that of a sole pilot weight of 65 kg up to the maximum weight, always considering the most unfavorable placing of luggage.

4.3.3.4 Fixed or removable ballast, or both, may be used if properly installed and placarded.

4.3.3.5 Multiple ESDs may be used if properly installed and placarded.

**4.4 Propeller Speed and Pitch Limits for a Powered Glider**—The operating limitations shall not allow the engine to exceed safe operating limits established by the engine manufacturer under normal conditions.

4.4.1 Maximum RPM shall not be exceeded with full throttle during takeoff, climb, or flight at  $0.9 V_H$ , and 110 % maximum continuous RPM shall not be exceeded during a glide at  $V_{NE}$  with throttle closed.

**4.5 Performance, General**—All performance requirements apply in standard ICAO atmosphere in still air conditions and at sea level. Speeds shall be given in indicated (IAS) and calibrated (CAS) airspeeds.

**4.5.1 Stalling Speeds:**

4.5.1.1 Wing level stalling speeds  $V_{S0}$  and  $V_S$  shall be determined by flight test at a rate of speed decrease of 1 knot/s or less, throttle closed, with maximum takeoff weight, and most unfavorable CG.

4.5.1.2 For powered gliders, wing level stalling speeds  $V_{S0}$  and  $V_S$  shall also be determined with the engine idling, propeller in the takeoff position, and the cowl flaps closed.

4.5.1.3 For powered gliders, wings level, level flight top speed  $V_H$  shall be determined by flight test at maximum continuous rated RPM or with full throttle, if unable to reach max continuous RPM, at maximum takeoff weight, in cruise configuration.

**4.5.2 Takeoff for a Powered Glider:**

4.5.2.1 With the glider at maximum takeoff weight and full throttle, the distance to clear a 15-m (50-ft) obstacle shall not exceed 600 m (2000 ft).

4.5.2.2 Takeoff must be demonstrated with crosswind components not less than  $0.2 V_{S0}$ .

NOTE 1—The procedure used for normal takeoff, including flap position, shall be specified within the AOI.

**4.5.3 Climb**—At maximum takeoff weight, flaps in the position specified for climb within the AOI, landing gear retracted, and full throttle, the minimum rate of climb shall exceed 1.0 m/s (200 ft/min).

**4.5.4 High Speed Descent**—If so equipped, the glider must not exceed  $V_{NE}$  in a dive at a  $30^\circ$  angle to the horizon with airbrakes extended.

**4.5.5 Descent**—If so equipped, the glider must have a glide slope not flatter than one in seven at a speed of  $1.3 V_{S0}$  at maximum weight and with airbrakes extended.

**4.5.6 Landing**—The following shall be determined:

4.5.6.1 Landing distance from 15 m (50 ft) above ground when speed at 15 m (50 ft) is  $1.3 V_{S0}$ .

4.5.6.2 Ground roll distance with braking if so equipped.

**4.6 Controllability and Maneuverability:**

**4.6.1 General:**

4.6.1.1 The glider shall be safely controllable and maneuverable during takeoff, climb, level flight, dive to  $V_{DF}$  or the maximum allowable speed for the configuration being investigated, engine extension and retraction, and approach and landing through the normal use of primary controls.

4.6.1.2 Smooth transition between all flight conditions shall be possible without exceeding pilot force as shown in Table 1.

**TABLE 1 Pilot Force**

Pilot force as applied to the controls	Pitch, N	Roll, N	Yaw, N	Wing flaps, landing gear, air brakes, retraction or extension of engine, two cable release, N
For temporary application: (less than 2 min) Stick	200	150	300	150
For prolonged application:	20	15	100	Not determined

4.6.1.3 Full control shall be maintained when retracting and extending flaps within their normal operating speed range ( $V_{S0}$  to  $V_{FE}$ ).

4.6.1.4 Lateral, directional, and longitudinal control shall be possible down to  $V_{S0}$ .

**4.6.2 Longitudinal Control:**

4.6.2.1 At steady flight, or if so equipped, with the aircraft trimmed as closely as possible for steady flight at  $1.3 V_{S1}$ , it must be possible at any speed below  $1.3 V_{S1}$  to pitch the nose downward so that a speed not less than  $1.3 V_{S1}$  can be reached promptly. This must be shown with the aircraft in all possible configurations.

4.6.2.2 Longitudinal control forces shall increase with increasing load factor.

**4.6.2.3 Longitudinal control must be maintained:**

(1) In towed flight, while extending or retracting flaps.

(2) When retraction or extension of the airbrakes is made at speeds between  $1.1 V_{S0}$  and  $1.5 V_{S0}$ .

(3) For powered gliders, when a change of the wing flap configuration is made during steady horizontal flight at  $1.1 V_S$  with simultaneous application of maximum continuous power.

(4) For powered gliders, when the engine is extended or retracted.

**4.6.3 Directional and Lateral Control:**

4.6.3.1 It must be possible, without significant slip or skid, to reverse the direction of a turn with a  $45^\circ$  bank to the opposite direction within  $b/3$  or 4 s, whichever is longer (where  $b$  is the span of the glider in meters), when the turn is made at a speed of  $1.4 V_{S1}$ , with where applicable, wing flaps, air brakes, and landing gear retracted.

4.6.3.2 With and without flaps deployed, rapid entry into or recovery from a maximum cross-controlled slip shall not result in uncontrollable flight characteristics.

4.6.3.3 Lateral and directional control forces shall not reverse with increased deflection.

**4.6.4 Aerotowing:**

4.6.4.1 If the glider is equipped for aerotowing, aerotows must be demonstrated at speeds up to  $V_T$  without:

(1) Difficulty in regaining the normal towing position after the glider has been displaced laterally or vertically.

(2) The released tow cable contacting any part of the glider.

4.6.4.2 Aerotowing must be demonstrated with crosswind components not less than  $0.2 V_{S0}$ .

4.6.4.3 A suitable range of tow cables must be established.

4.6.4.4 Tests must be repeated for each location of the towing release mechanism.

**4.6.5 Winch Launching:**

**TABLE 2 Static Longitudinal Stability Requirements**

Cruising Configuration
At all speeds between $1.1 V_{S1}$ and $V_{NE}$
Wing flaps in the position for cruising and for circling
Landing gear retracted
Glider trimmed at $1.4 V_{S1}$ and $2 V_{S1}$ (if equipped with a trimming device)
Air brakes retracted
Approach
At all speeds between $1.1 V_{S1}$ and $V_{FE}$
Wing flaps in the landing position
Landing gear extended
Glider trimmed at $1.4 V_{S0}$ (if equipped with a trimming device)
Air brakes retracted and extended
Climb for Powered Glider
At all speeds between $0.85 V_Y$ or $1.05 V_Y$
Wing flaps in the position for climb
Landing gear retracted
Glider trimmed at $V_Y$ (if equipped with a trimming device)
Maximum weight
Maximum continuous power
Cruise for Powered Glider
At all speeds between $1.3 V_{S1}$ and $V_{NE}$
Wing flaps retracted or in the case of flaps approved for use in cruise flight in all appropriate positions
Landing gear retracted
Glider trimmed for level flight (if equipped with a trimming device)
Maximum weight
Power set for horizontal flight at $0.9 V_H$
Approach for Powered Glider
At all speeds between $1.1 V_{S1}$ and $V_{NE}$
Wing flaps in the landing position
Landing gear extended
Glider trimmed at $1.5 V_{S1}$ (if equipped with a trimming device)
Maximum weight
Air brakes retracted and extended
Power set at idle

4.6.5.1 If the glider is equipped for winch launching or auto-tow launching, such launches must be demonstrated up to  $V_W$  without:

- (1) Uncontrolled roll after leaving the ground and upon a release,
- (2) Uncontrolled pitching oscillations, and
- (3) Control forces in excess of those listed in Table 1 and excessive deflections of the controls.

4.6.5.2 Winch launching must be demonstrated with crosswind components not less than  $0.2 V_{S0}$ .

4.6.5.3 If a trimming device is fitted, the position used during the climb must be listed in the AOI.

#### 4.6.6 Approach and Landing:

4.6.6.1 Normal approaches and landings until the glider comes to a complete halt must be demonstrated with crosswind components not less than  $0.2 V_{S0}$ .

4.6.6.2 The use of air brakes during approach will not cause control forces in excess of those listed in Table 1 or excessive control displacements, nor affect the controllability of the glider.

4.6.6.3 After touchdown, there must not be a tendency to ground loop, for pitching oscillation or to nose over.

#### 4.6.7 Static Longitudinal Stability:

4.6.7.1 The glider shall demonstrate the ability to trim for steady flight at speeds appropriate to the launch, flight, and landing approach configurations for gliders, and climb and cruise for powered gliders; at minimum and maximum weight; and forward and aft CG limits. If the glider has no in-flight adjustable longitudinal trimming device, the trim speed must be between  $1.2 V_{S1}$  and  $2.0 V_{S1}$  for all CG positions.

4.6.7.2 The glider shall exhibit positive longitudinal stability characteristics at any speed above  $V_{S1}$ , up to the maximum allowable speed for the configuration being investigated, and at the most critical power setting and CG combination.

4.6.7.3 Stability shall be shown by a tendency for the glider to return toward steady flight after: (1) a “push” from steady flight that results in a speed increase, followed by a non-abrupt release of the pitch control; and (2) a “pull” from steady flight that results in a speed decrease, followed by a non-abrupt release of the pitch control.

4.6.7.4 The glider shall demonstrate compliance with this section for the conditions listed in Table 2.

4.6.7.5 While returning toward steady flight, the aircraft shall:

- (1) Not decelerate below stalling speed  $V_{S1}$ ,
- (2) Not exceed  $V_{NE}$  or the maximum allowable speed for the configuration being investigated, and
- (3) Exhibit decreasing amplitude for any long-period oscillations.

#### 4.6.8 Static Directional and Lateral Stability:

4.6.8.1 There can be no tendency for the glider when in straight flight at  $1.4 V_{S1}$  with wing-flaps in all en-route positions, air brakes, and where applicable, landing gear retracted to:

- (1) Turn or bank when the aileron control is released and the rudder control held fixed in the neutral position, and
- (2) Yaw when the rudder control is released and the aileron control held fixed in the neutral position.

4.6.8.2 The glider shall exhibit positive directional and lateral stability characteristics at any speed above  $V_{S1}$ , up to the maximum allowable speed for the configuration being investigated, and at the most critical CG combination.

4.6.8.3 Powered glider must demonstrate:

(1) Retraction and extension of the power plant or propeller must not produce excessive trim changes,

(2) A climb at maximum continuous power at  $V_Y$  with landing gear retracted and wing flaps in the takeoff position is achievable with trimmed pitch controls, and

(3) Level flight at all speeds between  $V_Y$  and  $V_H$ , with the landing gear retracted and wing flaps in a position appropriate to each speed is achievable with trimmed pitch controls.

4.6.8.4 With the glider in straight and steady flight, and when the aileron and rudder controls are gradually applied in opposite directions, any increase in slideslip angle must correspond to an increased deflection of the lateral control. This behavior need not follow a linear law.

4.6.9 *Dynamic Stability*—Any short period oscillations shall be heavily damped within the appropriate speed range ( $V_{S0}$  to  $V_{FE}$  flaps extended and  $V_S$  to  $V_{DF}$  flaps retracted) for primary controls fixed and free. In the case of a powered glider, this requirement must be met with the engine running at all allowable powers.

#### 4.6.10 Wings Level Stall:

4.6.10.1 It shall be possible to prevent more than  $30^\circ$  of roll or yaw by normal use of the controls during the stall and the recovery at all weight and CG combinations.

4.6.10.2 The loss of altitude from a stall must be determined and listed in the AOI.

4.6.10.3 Minor yaw (up to 5°) shall not have a significant influence on the stall characteristics.

4.6.10.4 Compliance with this section must be demonstrated under the following conditions:

- (1) Wing flaps in any condition,
- (2) Air brakes retracted and extended,
- (3) Landing gear retracted and extended,
- (4) Glider trimmed to 1.4  $V_{S1}$  (if equipped with a trimming device),
- (5) Additionally, for powered gliders, cowl flaps must be in the appropriate configuration with the engine at idle and 90 % of maximum continuous power, and
- (6) During winch takeoff with the glider pitch 30° above the horizontal.

4.6.11 *Turning Flight Stalls:*

4.6.11.1 When stalled during a coordinated 45° banked turn, it must be possible to regain normal level flight without encountering uncontrollable rolling or spinning tendencies. Compliance with this requirement must be shown under the conditions of 4.6.10.4 that result in the most critical stall behavior of the glider. The landing configuration, with airbrakes retracted and extended, must be investigated.

4.6.11.2 The loss of altitude from beginning of the stall until regaining wings level flight and a speed of 1.4  $V_{S1}$  must be determined.

4.6.12 *Stall Warning:*

4.6.12.1 There must be a clear and distinctive stall warning with airbrakes, wing flaps, and landing gear in any normal position, both in straight and turning flight. In the case of a powered glider, compliance with this requirement must also be shown with the engine running in the conditions prescribed in 4.6.10.4(5).

4.6.12.2 The stall warning may be furnished either through the inherent aerodynamic qualities of the glider (that is, buffeting) or by a device that will give clearly distinguishable indications. A visual only stall warning is not acceptable.

4.6.12.3 The stall warning must begin:

- (1) In the speed range of 1.05  $V_{S1}$  to 1.1  $V_{S1}$ , or
- (2) 2 to 5 s before the stall occurs while the speed is decreasing at 1 knot/s.

4.6.13 *Spinning:*

4.6.13.1 For gliders placarded “no intentional spins,” the glider must be able to recover from a one-turn spin or a 3-s spin, whichever takes longer, in not more than one additional turn, with the controls used in the manner normally used for recovery.

4.6.13.2 For gliders in which intentional spinning is allowed, the glider must be able to recover from a three-turn spin in not more than one and one-half additional turn.

4.6.13.3 In addition, for either 4.6.13.1 or 4.6.13.2:

- (1) The applicable airspeed limit and limit maneuvering load factor shall not be exceeded,
- (2) Control forces during the spin or recovery shall not exceed those listed in Table 1, and
- (3) It must be impossible to obtain unrecoverable spins with any use of the controls.

4.6.14 *Spiral Dive Characteristics*—If there is any tendency for a spin to turn into a spiral dive, the glider must be able to recover from this condition without exceeding either the limiting air speed or the limiting maneuvering factor for the glider.

4.7 *Vibrations*—Flight testing shall not reveal by pilot observation heavy buffeting (except as associated with a stall), excessive airframe or control vibrations, flutter (with proper attempts to induce it), or control divergence at any speed from  $V_{S0}$  to  $V_{DF}$ .

4.8 *Ground Control and Stability*—There must not be any uncontrollable ground loop tendency at any speed at which a powered glider will operate on the ground up to the maximum crosswind component specified in 4.5.2.2.

5. Structure

5.1 General:

5.1.1 Loads:

5.1.1.1 Strength requirements are specified in terms of limit loads (the maximum loads to be expected in service) and ultimate loads (limit loads multiplied by prescribed factors of safety). Unless otherwise provided, prescribed loads are limit loads.

5.1.1.2 Unless otherwise provided, the air and ground loads must be placed in equilibrium with inertia forces, considering each item of mass in the aircraft. These loads must be distributed to conservatively approximate or closely represent actual conditions.

5.1.1.3 If deflections under load would significantly change the distribution of external or internal loads, this redistribution must be taken into account.

5.1.2 Factor of Safety:

5.1.2.1 Unless otherwise provided in 5.1.2.2, an ultimate load factor of safety of 1.5 must be used.

5.1.2.2 Special ultimate load factors of safety shall be applied according to Table 3.

5.1.3 Strength and Deformation:

5.1.3.1 The structure must be able to support limit loads without permanent deformation. At any load up to limit loads, the deformation shall not interfere with safe operation.

5.1.3.2 The structure must be able to support ultimate loads without failure for at least 3 s. However, when proof of strength is shown by dynamic tests simulating actual load conditions, the 3-s limit does not apply.

5.1.4 *Proof of Structure*—Each design requirement must be verified by means of conservative analysis or test (static, component, or flight), or both.

TABLE 3 Ultimate Load Factors

2.0 × 1.5 = 3.0	on castings
1.2 × 1.5 = 1.8	on fittings
2.0 × 1.5 = 3.0	on bearings at bolted or pinned joints subject to rotation
4.45 × 1.5 = 6.67	on control surface hinge-bearing loads except ball and roller bearing hinges
2.2 × 1.5 = 3.3	on push-pull control system joints
1.33 × 1.5 = 2	on cable control system joints, seat belt/harness fittings (including the seat if belt/harness is attached to it)

5.1.4.1 Compliance with the strength and deformation requirements of 5.1.3 must be shown for each critical load condition. Structural analysis may be used only if the structure conforms to those for which experience has shown this method to be reliable. In other cases, substantiating load tests must be made. Dynamic tests, including structural flight tests, are acceptable if the design load conditions have been simulated. Substantiating load tests should normally be taken to ultimate design load.

5.1.4.2 Certain parts of the structure must be tested as specified in 6.11.

5.2 Flight Loads:

5.2.1 General:

5.2.1.1 Flight Load Factors,  $n$ , represent the ratio of the aerodynamic force component (acting normal to the assumed longitudinal axis of the aircraft) to the weight of the aircraft. A positive flight load factor is one in which the aerodynamic force acts upward with respect to the glider.

5.2.1.2 Compliance with the flight load requirements of this section must be shown at each practicable combination of weight and disposable load within the operating limitations specified in the AOI.

5.2.2 Symmetrical Flight Conditions:

5.2.2.1 The appropriate balancing horizontal tail loads must be accounted for in a rational or conservative manner when determining the wing loads and linear inertia loads corresponding to any of the symmetrical flight conditions specified in 5.2.2-5.2.6.

5.2.2.2 The incremental horizontal tail loads due to maneuvering and gusts must be reacted by the angular inertia of the glider in a rational or conservative manner.

5.2.2.3 In computing the loads arising in the conditions prescribed above, the angle of attack is assumed to be changed suddenly without loss of air speed until the prescribed load factor is attained. Angular accelerations may be disregarded.

5.2.2.4 The aerodynamic data required for establishing the loading conditions must be verified by tests, calculations, or by conservative estimation. In the absence of better information, the maximum negative lift coefficient for rigid lifting surfaces shall be assumed to be equal to  $-0.80$ . If the pitching moment coefficient,  $C_{mo}$ , is less than  $\pm 0.025$ , a coefficient of at least  $\pm 0.025$  must be used.

5.2.3 Flight Envelope—Compliance shall be shown at any combination of airspeed and load factor on the boundaries of the flight envelope. The flight envelope represents the envelope of the flight loading conditions specified by the criteria of 5.2.4 and 5.2.5 (see Fig. 1).

5.2.3.1 General—Compliance with the strength requirements of this subpart must be shown at any combination of airspeed and load factor on and within the boundaries of the flight envelopes specified by the maneuvering and gust criteria of 5.2.3.2 and 5.2.3.3, respectively.

5.2.3.2 Maneuvering Envelope—Wing flaps are in the en-route setting and air brakes are closed (see Fig. 1).

5.2.3.3 Gust Envelope—Wing flaps in the en-route setting (see Fig. 2). At the design maximum speed  $V_D$ , the glider must be capable of withstanding positive (up) and negative (down) gusts of 7.5 m/s acting normal to the flight path.

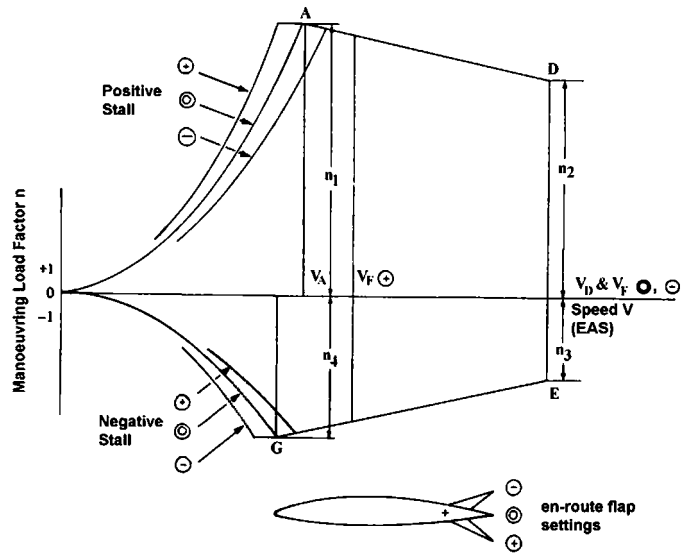

FIG. 1 Maneuvering Envelope

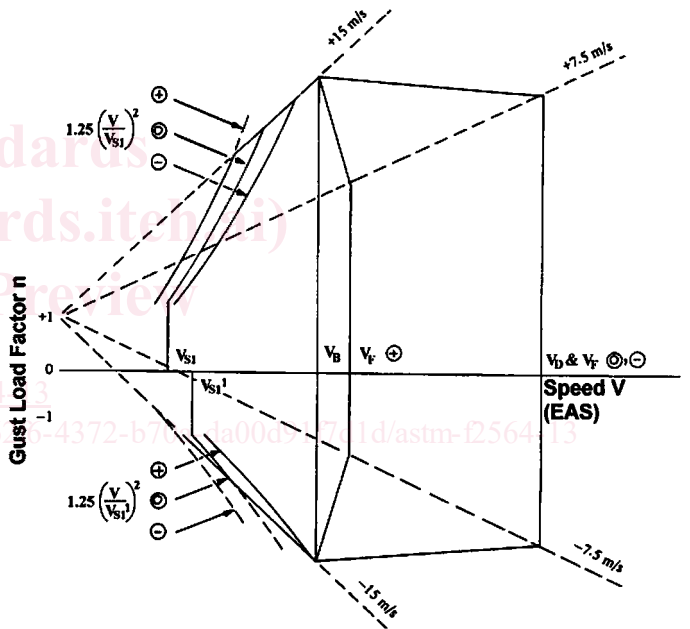

FIG. 2 Gust Envelope

5.2.4 Design Airspeeds:

5.2.4.1 Design Maneuvering Speed,  $V_A$ :

$$V_A = V_{S1} \sqrt{n_1} \tag{1}$$

where:

- $V_{S1}$  = estimated stalling speed at design maximum weight with wing-flaps and air brakes retracted, and
- $n_1$  = positive limit maneuvering load factor used in design.

5.2.4.2 Design Flap Speed,  $V_F$ —For each landing setting,  $V_F$  must not be less than the greater of: (1)  $1.4 V_S$ , where  $V_S$  is the computed stalling speed with the wing flaps retracted at the maximum weight; and (2)  $2.0 V_{SF}$ , where  $V_{SF}$  is the computed stalling speed with wing flaps fully extended at the maximum weight.