



Designation: **A934/A934M—07 A934/A934M – 13**

Standard Specification for Epoxy-Coated Prefabricated Steel Reinforcing Bars¹

This standard is issued under the fixed designation A934/A934M; the number immediately following the designation indicates the year of original adoption or, in the case of revision, the year of last revision. A number in parentheses indicates the year of last reapproval. A superscript epsilon (ϵ) indicates an editorial change since the last revision or reapproval.

1. Scope*

1.1 This specification covers deformed and plain steel reinforcing bars which prior to surface preparation are prefabricated and then coated with a protective fusion-bonded epoxy coating by electrostatic spray or other suitable method.

1.2 Prefabricated steel reinforcing bars coated with fusion-bonded epoxy ~~formulations~~ powder coating in accordance with this specification are ~~not intended to be bent or re-bent.~~ fabricated before being coated.

~~NOTE 1—Experience has shown epoxy-coated prefabricated steel reinforcing bars have limited capability to be successfully field bent or re-bent (see 9.3.1). If the construction project requires epoxy-coated steel reinforcing bars that must be able to sustain field bending or rebending, the use of coated bars conforming to Specification ~~A775/A775M~~ should be considered.~~

1.3 Organic coatings other than epoxy may be used provided they meet the requirements of this specification.

1.4 Requirements for epoxy coatings are contained in **Annex A1**.

1.5 Guidelines for application process and product test procedures of epoxy coatings for steel reinforcing bars are presented in **Appendix X1**.

1.6 Guidelines for construction practices at the job-site for coated steel reinforcing bars are presented in **Appendix X2**.

1.7 This specification is applicable for orders in either SI (metric) units (as Specification A934M) or inch-pound units [as Specification A934].

1.8 The values stated in either SI units or inch-pound units are to be regarded separately as standard. The values stated in each system may not be exact equivalents; therefore, each system shall be used independently of the other. Combining values from the two systems may result in non-conformance with the standard.

1.9 *This standard does not purport to address all of the safety concerns, if any, associated with its use. It is the responsibility of the user of this standard to establish appropriate safety and health practices and determine the applicability of regulatory limitations prior to use.*

2. Referenced Documents

2.1 ASTM Standards:²

A615/A615M Specification for Deformed and Plain Carbon-Steel Bars for Concrete Reinforcement

A706/A706M Specification for Low-Alloy Steel Deformed and Plain Bars for Concrete Reinforcement

A775/A775M Specification for Epoxy-Coated Steel Reinforcing Bars

A944 Test Method for Comparing Bond Strength of Steel Reinforcing Bars to Concrete Using Beam-End Specimens

A996/A996M Specification for Rail-Steel and Axle-Steel Deformed Bars for Concrete Reinforcement

B117 Practice for Operating Salt Spray (Fog) Apparatus

D4060 Test Method for Abrasion Resistance of Organic Coatings by the Taber Abraser

G8 Test Methods for Cathodic Disbonding of Pipeline Coatings

G14 Test Method for Impact Resistance of Pipeline Coatings (Falling Weight Test)

G20 Test Method for Chemical Resistance of Pipeline Coatings

G42 Test Method for Cathodic Disbonding of Pipeline Coatings Subjected to Elevated Temperatures

G62 Test Methods for Holiday Detection in Pipeline Coatings

¹ This specification is under the jurisdiction of ASTM Committee A01 on Steel, Stainless Steel and Related Alloys and is the direct responsibility of Subcommittee A01.05 on Steel Reinforcement.

Current edition approved ~~Sept. 1, 2007~~ June 1, 2013. Published ~~October 2007~~ June 2013. Originally approved in 1995. Last previous edition approved in ~~2004~~ 2007 as A934/A934M-04. DOI: 10.1520/A0934_A0934M-07. DOI: 10.1520/A0934_A0934M-13.

² For referenced ASTM standards, visit the ASTM website, www.astm.org, or contact ASTM Customer Service at service@astm.org. For *Annual Book of ASTM Standards* volume information, refer to the standard's Document Summary page on the ASTM website.

*A Summary of Changes section appears at the end of this standard

2.2 *NACE International Standard:*³

RP 0287 Field Measurement of Surface Profile of Abrasive Blast Cleaned Steel Surfaces Using a Replica Tape

2.3 *Society for Protective Coatings Specifications:*⁴

SSPC-SP 10 Near-White Blast Cleaning

SSPC-VIS 1 Pictorial Surface Preparation Standards for Painting Steel Surfaces

SSPC-PA 2 Measurement of Dry Coating Thickness with Magnetic Gages

2.4 *American Concrete Institute Specifications:*⁵

ACI 301 Specifications for Structural Concrete

ACI 315 Details and Detailing of Concrete Reinforcement

2.5 *Concrete Reinforcing Steel Institute:*⁶

Voluntary Certification Program for Fusion-Bonded Epoxy Coating Applicator Plants

3. Terminology

3.1 *Definitions of Terms Specific to This Standard:*

3.1.1 *conversion coating*—preparation of the blast-cleaned metal surface prior to coating application that is designed to pretreat the metal to promote coating adhesion, reduce metal coating reactions, improve corrosion resistance, and increase blister resistance.

3.1.2 *disbonding*—loss of adhesion between the fusion-bonded epoxy coating and the steel reinforcing bar.

3.1.3 *fusion-bonded epoxy coating*—product containing pigments, thermosetting epoxy resins, crosslinking agents, and other additives, which is applied in the form of a powder onto a clean, heated metallic substrate and fuses to form a continuous barrier coating.

3.1.4 *holiday*—discontinuity in a coating that is not discernible to a person with normal or corrected vision.

3.1.5 *patching material*—liquid two-part epoxy coating used to repair damaged areas.

3.1.6 *prefabricated bars*—steel reinforcing bars that are cut to specified lengths and bent to the required shapes prior to coating.

3.1.7 *wetting agent*—material that lowers the surface tension of water allowing it to penetrate more effectively into small discontinuities in the coating, giving a more accurate indication of the holiday count.

4. Ordering Information

4.1 It shall be the responsibility of the purchaser to specify all requirements that are necessary for the coated steel reinforcing bars under this specification. Such requirements to be considered include, but are not limited to, the following:

4.1.1 Reinforcing bar specification and year of issue,

4.1.2 Quantity and bend types of bars,

4.1.3 Size and grade of bars,

4.1.4 Requirements for the powder coating and provision of test data (5.2),

4.1.5 Requirements for patching material (5.3),

4.1.6 Quantity of patching material,

4.1.7 Coated specimens shall be provided by the manufacturer out of the same production lot of coated reinforcement being furnished to the purchaser (13.1).

4.1.8 Whether a report on tests performed on the coated steel reinforcing bars being furnished is required (15.1),

4.1.9 Method for temperature reduction of hot, freshly coated bars (unforced air cool down or forced air/water quench) (8.3).

NOTE 1—A typical ordering description is as follows: Deformed Grade 420 bars to ASTM A615M – ____; 6000 m, No. 19; cut to specified lengths and fabricated prior to coating; epoxy-coated to ASTM A934M – ____; including written certifications for the powder coating and coated bars and 1 L of patching material.

[Deformed Grade 60 bars to ASTM A615M – ____; 20 000 ft, No. 6; cut to specified lengths and fabricated prior to coating; epoxy-coated to ASTM A934 – ____; including written certifications for the powder coating and coated bars and 1 qt. of patching material.

5. Materials

5.1 Steel reinforcing bars to be coated shall meet the requirements of one of the following specifications: A615M, A706M, or A996M [A615, A706, or A996] as specified by the purchaser and shall be free of contaminants such as oil, grease, or paint.

NOTE 2—Prior to coating, the steel reinforcing bars should be inspected for their suitability for coating. Bars with sharp edges on the deformations, rolled-in slivers, or other surface imperfections are difficult to coat properly. The coating will flow away from the sharp edges and may result in inadequate coating thickness at these points.

³ Available from NACE International, 1440 South Creek Dr., Houston, TX 77084-4906.

⁴ Available from The Society for Protective Coatings, 40 24th St., Pittsburgh, PA 15222-4656.

⁵ Available from American Concrete Institute, 38800 Country Club Dr., Farmington Hills, MI 48331.

⁶ Available from Concrete Reinforcing Steel Institute, 933 N. Plum Grove Rd., Schaumburg, IL 60173-4758.



5.2 The powder coating shall meet the requirements of **Annex A1**. Upon request, the purchaser shall be provided with test data for review.

5.2.1 A written certification shall be furnished to the purchaser that properly identifies the lot designation of the powder coating used in the order, material quantity represented, date of manufacture, name and address of the powder coating manufacturer, and a statement that the supplied powder coating is the same composition as that qualified according to **Annex A1** of this specification. The powder coating shall be used within the powder coating manufacturer's written recommended shelf life.

5.2.2 If specified in the order, a representative 0.2-kg [8-oz] sample of the powder coating shall be supplied to the purchaser from each batch. The sample shall be packaged in an airtight container and identified by the batch designation.

5.2.3 The powder coating shall be maintained in a temperature-controlled environment following the written recommendations of the powder coating manufacturer until ready for use, at which point the powder coating shall be given sufficient time to reach approximate plant ambient temperature.

5.3 If specified in the order, patching material, compatible with the coating, inert in concrete, and recommended by the powder coating manufacturer, shall be supplied to the purchaser.

6. Prefabrication of Steel Reinforcing Bars

6.1 The steel reinforcing bars to be coated shall have been prefabricated in accordance with the purchaser's requirements or project specifications prior to surface preparation.

NOTE 3—Drive rolls on shear beds and backup barrels on benders should be protected with a suitable covering to minimize crushing or creating rollover damage to the steel reinforcing bar deformations during the fabrication process.

7. Surface Preparation of Steel Reinforcing Bars

7.1 The surface of the steel reinforcing bars shall be cleaned by abrasive blast steel grit to near-white metal in accordance with SSPC-SP 10.

7.1.1 The final surface condition shall be defined according to SSPC-VIS 1.

7.1.2 Average blast profile roughness depth readings of 37 to 100 μm [1.5 to 4.0 mils], as determined by replica tape measurements using RP 0287 or other methods acceptable to the purchaser, shall be considered suitable as an anchor pattern.

NOTE 4—The use of a profilometer type surface measurement instrument that measures the peak count as well as the maximum profile depth is recommended.

7.2 A steel grit of Rockwell Hardness C50 or higher shall be used. A maximum of 5 % steel shot is allowable in the media.

NOTE 5—Recycled steel grit abrasive should be maintained so as to minimize contaminants such as oil, salt, and dust caused by the blasting operation.

7.3 Multidirectional, high-pressure dry air knives shall be used after blast cleaning to remove dust, grit, and other foreign matter from the steel surface. The air knives shall not deposit oil on the steel reinforcing bars.

NOTE 6—It is recommended that incoming steel reinforcing bars and blast media be checked for salt contamination prior to use. Blast media found to be salt contaminated should be rejected. Steel reinforcing bars found to be salt contaminated from exposure to deicing salts or salt spray should be cleaned by acid washing or other suitable methods to remove salt contaminants from the surface prior to blast cleaning.

7.4 It shall be permissible for the manufacturer to use a chemical wash or conversion of the steel reinforcing bar surface, or both, to enhance coating adhesion. This pretreatment shall be applied after abrasive cleaning and before coating, in accordance with the written application instructions specified by the pretreatment manufacturer.

8. Coating Application

8.1 Cleaned, uncoated steel reinforcing bars shall be handled by personnel wearing clean gloves to prevent contamination of the steel surface.

8.2 If pretreatment is used in the preparation of the surface the powder coating shall be applied to the cleaned and pretreated steel reinforcing bar surface as soon as possible after surface treatments have been completed, and before visible oxidation of the surface occurs as discernible to a person with normal or corrected vision. In no case shall application of the coating be delayed more than 3 h after cleaning.

8.3 The fusion-bonded epoxy powder coating shall be applied in accordance with the written recommendations of the manufacturer of the powder coating for initial steel surface temperature range and post application cure requirements. The temperature of the surface immediately prior to coating shall be measured using infrared guns or temperature-indicating crayons at least once every 30 min during continuous operations.

NOTE 7—The use of infrared and temperature-indicating crayon measurement of the steel reinforcing bars is recommended.

8.4 The powder coating shall be applied by electrostatic spray or other suitable method.

9. Requirements for Coated Steel Reinforcing Bars

9.1 *Coating Thickness:*

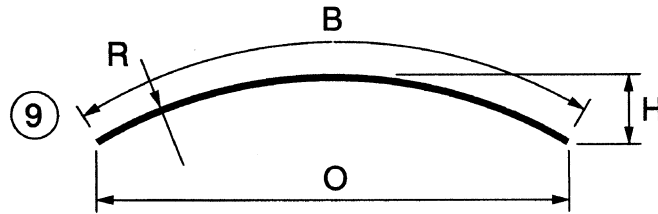

FIG. 1 Bend Type 9 (ACI 315)

9.1.1 The coating thickness on straight sections of bars, after curing, shall be 175 to 300 μm [7 to 12 mils]. The coating thickness on bent sections of bars, after curing, shall be 175 to 405 μm [7 to 16 mils]. Bent sections of bars are defined as the entire radius of each bend and portions of the bar extending 150 mm [6 in.] beyond the beginning and ending bend points on the bar. Bars that are bent with a radius such as Bend Type 9 (Fig. 1) shall have the same coating thickness requirements as straight bars, when the "H" dimension is equal to or less than one-half of the "R" dimension.

NOTE 8—Section 9.1.1 permits a maximum coating thickness of 405 μm [16 mils] on bent sections of bars. Discussion of the effect of the permissible increased coating thickness on the anchorage capacity of bent bars embedded in concrete is presented in Appendix X3.

9.1.2 A single recorded steel reinforcing bar coating thickness measurement is the average of three individual gage readings obtained between three consecutive deformations. A minimum of five recorded measurements shall be taken approximately evenly spaced along each side of the test specimen (a minimum of ten recorded measurements per bar).

9.1.3 For acceptance purposes, the average of all recorded coating thickness measurements shall not be less than the specified minimum thickness or more than the specified maximum thickness. No single recorded coating thickness measurement shall be less than 80 % of the specified minimum thickness or more than 120 % of the specified maximum thickness.

9.1.4 Measurements shall be made in accordance with SSPC-PA 2 following the instructions for calibration and use recommended by the thickness gage manufacturer. Pull-off or fixed probe gages shall be used. Pencil-type pull-off gages that require the operator to observe the readings at the instant the magnet is pulled from the surface shall not be used.

9.1.5 Approximately equal numbers of straight and bent sections of coated steel reinforcing bars shall be evaluated. On the bent sections, approximately half of these measurements shall be made on the inside radius and half on the outside radius.

9.2 Coating Continuity:

9.2.1 Holiday checks to determine the acceptability of the coated steel reinforcing bars prior to shipment shall be made at the manufacturer's plant with a handheld 67.5-V, 80 000- Ω , wet-sponge-type dc holiday detector.

9.2.2 There shall not be on average more than three holidays per metre [one holiday per linear foot] on the coated steel reinforcing bars. The average applies to the full production length of a bar. For coated bars less than 0.3 m [1 ft] in length, the maximum shall be one holiday.

9.2.3 A wetting agent shall be used in accordance with Test Methods G62 in the inspection for holidays on the coated steel reinforcing bars.

9.2.4 The coated steel reinforcing bars shall be inspected at a maximum rate of 0.05 m/s [0.2 ft/s], wiping one side of the coated bar and then the other with the wetted sponge or an equivalent method.

NOTE 9—Care should be taken that contact of the sponge along the entire steel surface being tested is maintained in order to obtain an accurate holiday count.

9.3 Coating Flexibility:

9.3.1 Coating flexibility shall be evaluated by bending production-coated steel reinforcing bars around a mandrel eight times the nominal diameter (d) of the bar at a uniform rate and within 5 s. The exception to the $8d$ mandrel requirement shall be Nos. 43 and 57 [Nos. 14 and 18] bars. A 430-mm [17-in.] mandrel ($9.71d$) shall be used when evaluating No. 43 [No. 14] bar, and a 580-mm [23-in.] mandrel ($10.22d$) shall be used with No. 57 [No. 18] bar. For Nos. 10 to 16 [Nos. 3 to 5] coated steel reinforcing bars, the bend angle after rebound shall be 9° . For No. 19 to 57 [Nos. 6 to 18] coated steel reinforcing bars, the bend angle after rebound shall be 6° . The two longitudinal deformations shall be placed in a plane perpendicular to the mandrel radius. The temperature of the test specimens shall be between 20 and 30°C [68 and 86°F].

9.3.2 Cracking or disbonding of the coating on the outside radius of the bent bar discernible to a person with normal or corrected vision shall be considered cause for rejection of the coated steel reinforcing bars represented by the bend test sample.

9.4 Coating Adhesion:

9.4.1 Coating adhesion shall be evaluated by cathodic disbondment testing of production-coated steel reinforcing bars. Test Method G42 shall be followed except, (1) the cathode shall be a 200-mm [8-in.] long coated steel reinforcing bar; (2) the anode shall be a 150-mm [6-in.] long solid platinum electrode (1.6-mm [0.06-in.] nominal diameter) or platinized wire (3-mm [0.12-in.] nominal diameter); (3) a calomel reference electrode shall be used; (4) the electrolyte solution shall be 3 % NaCl by mass dissolved in distilled water; (5) the electrolyte solution temperature shall be $65 \pm 2^\circ\text{C}$ [$150 \pm 3.6^\circ\text{F}$]; (6) the drilled coating defect shall be

3 mm [0.12 in.] in diameter; (7) a potential of -3 V measured against the calomel reference electrode shall be applied and a 10-ohm shunt resistor used, and; (8) the test duration shall be 24 h.

9.4.2 Following the 24-h exposure and prior to coating evaluation, the coated steel reinforcing bar shall be given a minimum of a 1-h cooling-off period to allow the bar to reach 20 to 30°C [68 to 86°F].

9.4.3 Measurements of the cathodic disbondment radius shall be obtained at 0°, 90°, 180°, and 270°. The average of the four values shall not exceed 6 mm [0.24 in.] when measured from the edge of the intentional coating defect.

9.4.4 Approximately even numbers of straight and bent sections of coated steel reinforcing bars shall be evaluated (approximately half of these tests shall be made on the inside radius and half on the outside radius on the bent bar sections).

10. Frequency of Tests

10.1 Tests for coating thickness shall be made on a minimum of two bars of straight section and two bars of bent section of each size from each production hour.

10.2 Tests for coating continuity shall be conducted on a minimum of two bars of each size from each production hour.

10.3 Tests for coating flexibility shall be made on a minimum of one bar of each bar size from each four production hours.

10.4 Tests for coating adhesion shall be made on a minimum of two bars from each 8-h production shift: one straight bar section and one bent bar section. If there are no bent bars being coated during the production period, a second straight bar section shall be substituted for the test.

11. Retests

11.1 If any test specimen for coating thickness, continuity, flexibility, or adhesion fails to meet the specified requirements, the bar from which the test specimen was taken shall be rejected and two further coated steel reinforcing bars from the same lot shall be subjected to the test or tests in which the original bar failed. If both additional coated steel reinforcing bars pass the retest, the lot from which they were taken shall be deemed to meet the requirements of this specification. If either of them fails, the lot shall be deemed not to comply with this specification.

11.2 If the lot does not comply with this specification, two coated steel reinforcing bars shall be selected from the lot immediately preceding and immediately following the non-compliant lot and subjected to the test or tests in which the original bars failed. If all bars pass the retests, then the lots shall be deemed to meet the requirements of this specification. If any bar fails a retest, the lot from which it originated shall be deemed not to comply with this specification.

11.3 In the case of a second noncompliant lot, the untested lot immediately next to it, which may be preceding or following, shall be subjected to retest. This procedure shall be repeated until a compliant lot is tested.

NOTE 10—In the use of the Retest provision of this specification, a “lot” is defined as the coated steel reinforcing bars that are represented by the sample which has been tested. A certain number of coated steel reinforcing bars will have been produced since the last acceptance test was performed and accepted. The steel reinforcing bars that have been coated since that last test should be divided into four equal time period groups according to when they were produced. Each lot should then be further defined as those coated steel reinforcing bars that have been produced in a given time period since the last accepted test.

12. Permissible Amount of Damaged Coating and Repair of Damaged Coating

12.1 Damaged coating discernible to a person with normal or corrected vision shall be repaired with patching material meeting the requirements of 5.3 in accordance with the written recommendations of the patching material manufacturer. Any rust shall be removed by suitable means before application of the patching material.

12.2 The maximum amount of repaired damaged coating shall not exceed 1 % of the total surface area in each 0.3-m [1-ft] length.

NOTE 11—If the amount of repaired damaged coating in any 0.3-m [1-ft] length of a coated bar exceeds 1 %, that section should be removed from the coated steel reinforcing bar and discarded. In patching damaged coating, care should be taken not to apply the patching material over an excessive area of the intact coating during the repair process. Too large an area of thick patching material, especially on smaller-size reinforcing bars, is likely to cause a reduction in bond strength of the bars to concrete.

12.3 Repaired areas shall have a minimum thickness of 250 μ m [10 mils].

13. Inspection

13.1 The inspector representing the owner/purchaser shall have free entry at all times, while work on the contract of the purchaser is being performed, to the parts of the manufacturer’s coating line that concern the manufacture of the coated steel reinforcing bar ordered. The manufacturer shall provide access to all reasonable facilities to satisfy the inspector that the coated steel reinforcing bar is being furnished in accordance with this specification. All tests and inspections shall be made at the place of manufacture prior to shipment unless otherwise specified, and shall be conducted so as not to interfere unnecessarily with the operation of the coating line. At a mutually agreed upon frequency, the purchaser or the purchaser’s representative shall be permitted to take lengths of coated steel reinforcing bar from the production run for testing.



14. Rejection

14.1 Coated steel reinforcing bars represented by test specimens that do not meet the requirements of this specification shall be rejected and marked with a contrasting color paint or other suitable identification. At the manufacturer's option, the affected lot shall be replaced or, alternately, stripped of coating, recleaned, recoated, and resubmitted for acceptance testing in accordance with the requirements of this specification.

NOTE 12—If the coating is not to be stripped from the rejected steel reinforcing bars, the bars should be scrapped.

15. Certification

15.1 The purchaser shall be furnished, at the time of shipment, written certification that samples representing each lot of coated steel reinforcing bars have been either tested or inspected as directed in this specification and the requirements have been met. When specified in the purchase order or contract, a report of the test results shall be furnished.

15.2 A material test report, certificate of inspection, or similar document printed from or used in electronic form from an electronic data interchange (EDI) transmission shall be regarded as having the same validity as a counterpart printed in the certifier's facility. The content of the EDI-transmitted document must meet the requirements of the invoked ASTM standard(s) and conform to any EDI agreements between the purchaser and the supplier. Notwithstanding the absence of a signature, the organization submitting the EDI transmission is responsible for the content of the report.

NOTE 13—EDI is used here as a computer-to-computer exchange of business information in a standard format such as ANSI ASC X12.

16. Handling and Identification

16.1 Coated steel reinforcing bars shall be transported and handled with care. All systems for handling coated steel reinforcing bars shall have padded contact areas. All bundling bands shall be padded, or suitable banding used to prevent damage to the coating. All bundles of coated steel reinforcing bars shall be lifted with a strong back, spreader bar, multiple supports, or a platform bridge to prevent bar-to-bar abrasion from sags in the bundles. The coated steel reinforcing bars or bundles shall not be dropped or dragged.

16.2 Smaller pieces of coated steel reinforcing bars, such as stirrups and ties, shall be packaged in such a way as to minimize damage to the coating during shipping and handling.

16.3 If circumstances require storing coated steel reinforcing bars outdoors for more than two months, protective storage measures shall be implemented to protect the material from sunlight, salt spray, and weather exposure. If the manufacturer stores coated steel reinforcing bars outdoors without cover, the date on which the coated bars are placed outdoor shall be recorded on the identification tag of the bundled steel. Coated steel reinforcing bars stored in severe corrosive environments will require protection sooner. Coated steel reinforcing bars or bundles shall be covered with opaque polyethylene sheeting or other suitable opaque protective material. For stacked bundles, the protective covering shall be draped around the perimeter of the stack. The covering shall be secured adequately, and allow for air circulation around the bars to minimize condensation under the covering.

16.4 All coated steel reinforcing bars or bundles shall be stored off the ground on protective cribbing.

16.5 The identification of all steel reinforcing bars shall be maintained throughout the fabrication and coating process to the point of shipment.

16.6 Quality assurance codes that certify compliance to this specification shall be placed on all identification tags of the coated steel reinforcing bars or bundles. These codes shall include references to the date of fabrication, the date of coating, the powder coating lot designation and the quality assurance testing performed.

17. Keywords

17.1 concrete reinforcement; corrosion resistance; epoxy coating; prefabrication; steel reinforcing bars



ANNEX

(Mandatory Information)

A1. REQUIREMENTS FOR FUSION-BONDED EPOXY POWDER COATINGS FOR PREFABRICATED STEEL REINFORCING BARS

A1.1 Epoxy Powder Coatings

A1.1.1 This annex covers qualification requirements for fusion-bonded epoxy powder coatings for protecting steel reinforcing bars from corrosion.

A1.1.2 Other organic coatings may be used provided they meet the requirements of this specification.

A1.2 Test Materials

A1.2.1 A 0.5-kg [1-lb] sample of the powder coating with its generic description and its fingerprint (including the method such as infrared spectroscopy or thermal analysis) shall be submitted to the testing agency. The fingerprint and generic description shall become an integral part of the qualification test report.

A1.2.2 A sample of patching material shall be submitted to the testing agency. The product name and a description of the patching material shall be given in the test report.

A1.2.3 Test Specimens:

A1.2.3.1 The following specimens shall be submitted as a minimum for testing:

(1) Fourteen 1.2-m [4-ft] long No. 19 [No. 6], Grade 420 [Grade 60] deformed steel reinforcing bars, with a coating thickness of 175 to 300 μm [7 to 12 mils].

(2) Six uncoated and uncleaned No. 19 [No. 6] steel reinforcing bars, 1.2 m [4 ft] long, from the same lot of steel as the coated bars.

(3) Four 100 by 100 by 1.3-mm [4 by 4 by 0.05-in.] thick steel plates with center holes for Taber abrasers with a coating thickness of $250 \pm 50 \mu\text{m}$ [10 ± 2 mils].

(4) Four 100 by 100-mm [4 by 4-in.] free films of coating material with a thickness of 175 to 225 μm [7 to 9 mils].

(5) Twelve coated No. 19 [No. 6] steel reinforcing bars, 0.25-m [10-in.] long, with a coating thickness of 175 to 300 μm [7 to 12 mils]. The coated bars shall have their ends sealed with a minimum of 250 μm [10 mils] of patching material.

(6) Ten coated No. 19 [No. 6] steel reinforcing bars, 0.20-m [8-in.] long, with a coating thickness of 175 to 300 μm [7 to 12 mils]. The coated bars shall have their ends sealed with a minimum of 250 μm [10 mils] of patching material.

A1.2.3.2 Steel reinforcing bars with a nominal diameter within $\pm 1 \text{ mm}$ [0.04 in.] of No. 19 [No. 6] bars shall be acceptable for qualification testing.

A1.2.3.3 The coating on the bars and films tested shall be free of holes, voids, contamination, cracks, and damaged areas. The coated bars shall be checked for holidays using a 67.5-V, 80 000- Ω , wet-sponge-type dc holiday detector in accordance with Test Method G62. The total number of coating holidays found on the bar specimens tested shall be reported.

A1.2.3.4 The powder coating manufacturer shall specify the method and grade of metal surface preparation and the coating application procedures for the test specimens and for contract production of coated steel reinforcing bars. These procedures shall be listed in the test report. Note that production-coated steel reinforcing bars shall be required to be manufactured in the same manner as the qualification bars. Therefore, it is necessary that the qualification coated steel reinforcing bars be prepared in the same manner proposed for production. Variations in the critical preparation, thermal treatment, coating procedures and cure methods known to be allowable without a compromise in quality shall also be detailed in the qualification report.

Test Bar Preparation

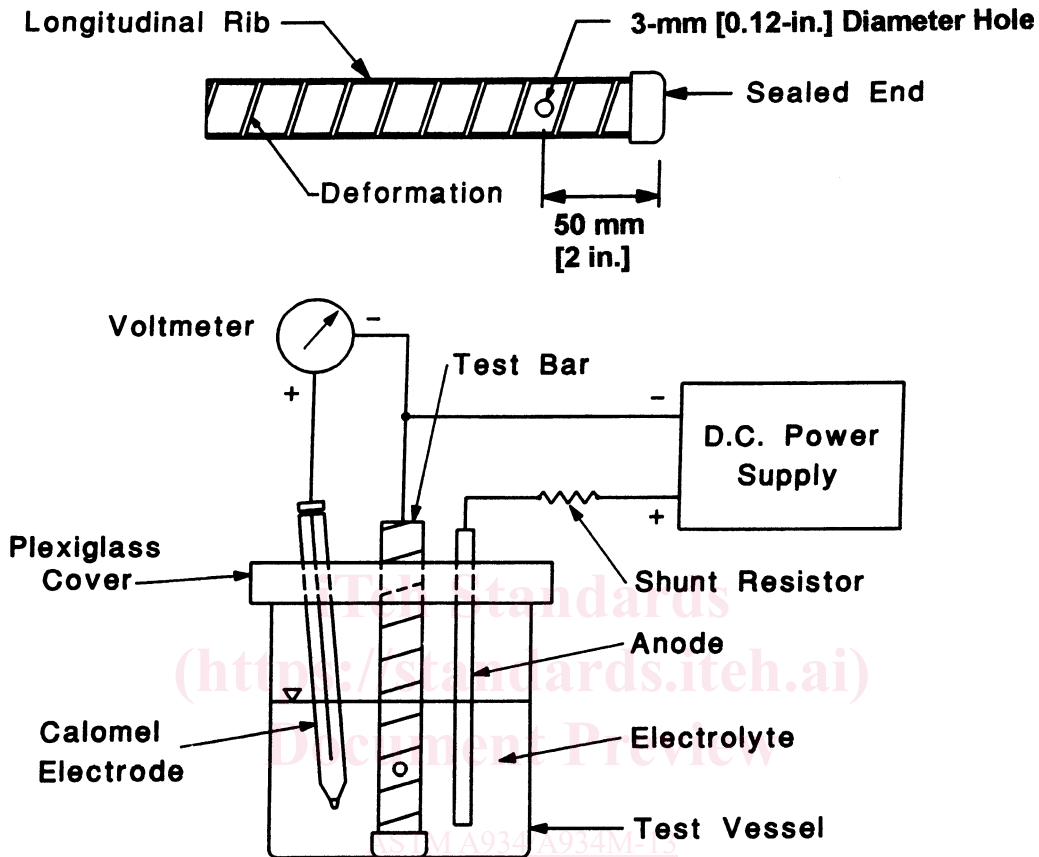

FIG. A1.1 Cathodic Disbondment Test Equipment Configuration

A1.3 Coating Requirements

A1.3.1 Chemical Resistance—The chemical resistance of the coating shall be evaluated in accordance with Test Method G20 by immersing coated steel reinforcing bars in each of the following: distilled water, a 3-M aqueous solution of CaCl_2 , a 3-M aqueous solution of NaOH , and a solution saturated with $\text{Ca}(\text{OH})_2$. Specimens without holidays and specimens with an intentional 6-mm [0.25-in.] diameter hole drilled through the coating shall be tested. The temperature of the test solutions shall be $24 \pm 2^\circ\text{C}$ [$75 \pm 3.6^\circ\text{F}$]. The immersion shall last 45 days. The coating must not blister, soften, lose bond, or develop holidays during this period. The coating surrounding the intentionally made hole shall exhibit no undercutting during the 45-day period.

A1.3.2 Cathodic Disbondment—The effects of electrical and electrochemical stresses on the bond of the coating to steel and on the film integrity shall be assessed in elevated and ambient temperature cathodic disbondment tests. Fig. A1.1 presents the recommended equipment configuration for performing cathodic disbondment testing on steel reinforcing bars. The intentional coating defect shall be placed approximately 50 mm [2 in.] from the sealed end of the test bar centered between the longitudinal and transverse ribs. It shall be drilled just deep enough to expose a full 3-mm [0.12-in.] diameter in the steel. The test bar shall be inserted with the sealed end of the bar resting on the bottom of the test vessel and electrolyte added until 100 mm [4 in.] of the bar length is submerged.

A1.3.2.1 Test A—Test Method G42 shall be followed except, (1) the cathode shall be a 200-mm [8-in.] long coated steel reinforcing bar; (2) the anode shall be a 150-mm [6-in.] long solid platinum electrode (1.6-mm [0.06-in.] nominal diameter) or platinized wire (3-mm [0.12-in.] nominal diameter); (3) a calomel reference electrode shall be used; (4) the electrolyte solution shall be 3 % NaCl by mass dissolved in distilled water; (5) the electrolyte solution temperature shall be $65 \pm 2^\circ\text{C}$ [$150 \pm 3.6^\circ\text{F}$];

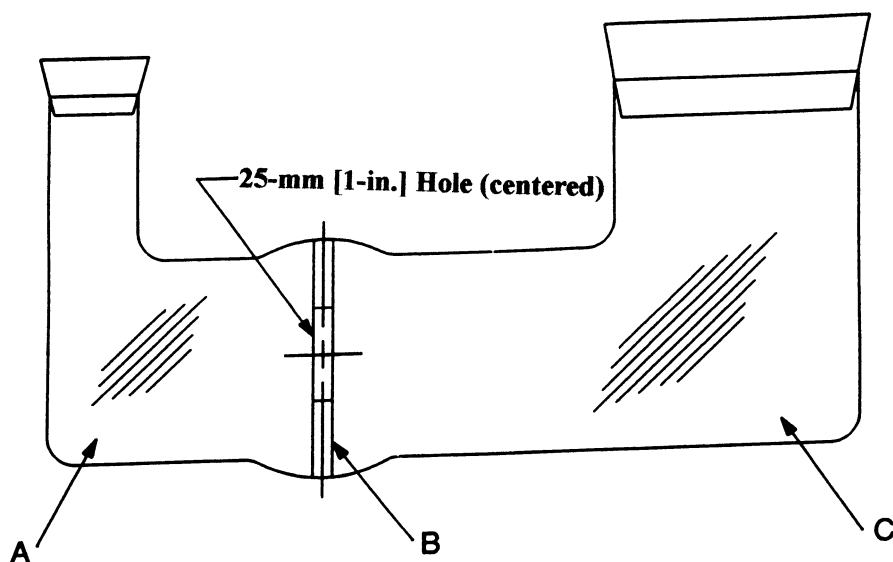

Permeability Cell Components:

- A. Component containing distilled water**
- B. Epoxy film sandwich between two glass plates each having a centered 25-mm [1-in.] diameter hole**
- C. Component containing 3M NaCl**

FIG. A1.2 Chloride Permeability Test Equipment Configuration

(6) the drilled coating defect shall be 3 mm [0.12 in.] in diameter; (7) a potential of -3 V measured against the calomel reference electrode shall be applied and a 10-ohm shunt resistor used; and (8) the test duration shall be 24 h. The tested bars shall be allowed to cool for approximately 1 ± 0.25 h prior to evaluation. Four measurements shall be taken, at 0° , 90° , 180° , and 270° , and the values averaged. The average coating disbondment radius of three coated steel reinforcing bars shall not exceed 6 mm [0.24 in.] when measured from the edge of the intentional coating defect.

A1.3.2.2 *Test B*—Test Method G8 shall be followed except, (1) the cathode shall be a 200-mm [8-in.] long coated steel reinforcing bar; (2) the anode shall be a 150-mm [6-in.] long solid platinum electrode (1.6-mm [0.06-in.] nominal diameter) or platinized wire (3-mm [0.12-in.] nominal diameter); (3) a calomel reference electrode shall be used; (4) the electrolyte solution shall be 3 % NaCl by mass dissolved in distilled water; (5) the electrolyte solution temperature shall be $23 \pm 2^\circ\text{C}$ [$74 \pm 3.6^\circ\text{F}$]; (6) the drilled coating defect shall be 3 mm [0.12 in.] in diameter; (7) a potential of -1.5 V measured against the calomel reference electrode shall be applied and a 10-ohm shunt resistor used; and (8) the test duration shall be 168 h. The tested bars shall be allowed to cool for approximately 1 ± 0.25 h prior to evaluation. Four measurements shall be taken, at 0° , 90° , 180° , and 270° , and the values averaged. The average coating disbondment radius of three coated steel reinforcing bars shall not exceed 2 mm [0.08 in.] when measured from the edge of the intentional coating defect.

A1.3.3 *Salt Spray Resistance*—The resistance of the coating to a hot, wet corrosive environment shall be evaluated in accordance with Practice B117 by exposing 200-mm [8-in.] long coated steel reinforcing bars containing intentional defects to $35 \pm 2^\circ\text{C}$ [$95 \pm 3.6^\circ\text{F}$] salt spray comprised of 5 % NaCl by mass dissolved in distilled water for 800 ± 20 h. Three intentional 3-mm [0.12-in.] diameter defects shall be drilled through the coating of each test bar approximately evenly spaced along one side of the bar with the holes centered between deformations. The coated steel reinforcing bars shall be placed horizontally in the cabinet with the damage sites facing the side (90°). The tested bars shall be allowed to cool for approximately 1 ± 0.25 h prior to evaluation. Four measurements shall be taken, at 0° , 90° , 180° , and 270° , and the values averaged. The average coating disbondment radius of nine test sites on three coated steel reinforcing bars shall not exceed 3 mm [0.12 in.] when measured from the edge of the intentional coating defect.

A1.3.4 *Chloride Permeability*—The chloride permeability characteristics of the cured coating having a thickness of 175 to 225 μm [7–9 mils] shall be measured on two test films and a control film at $24 \pm 2^\circ\text{C}$ [$75 \pm 3.6^\circ\text{F}$] for 45 days. The permeability cells shall be of the type shown in Fig. A1.2. Films selected for testing shall be carefully handled and examined for any defects prior to installation in the cell. The cell shall consist of two glass compartments separated by a coating film sandwiched between two

glass plates, each having a centered 25-mm [1-in.] hole. One compartment shall contain 175 mL [5.3 oz] of 3M NaCl and the other 115 mL [3.5 oz] of distilled water. The activity of chloride ions passing through the film shall be measured using a specific ion meter equipped with a chloride electrode and a double junction reference electrode. Activity measurements shall be converted into concentration values of mole per L [M] with a conversion diagram, constructed by plotting measured chloride ion activities versus known chloride ion concentrations. The cumulative concentration of chloride ions permeating through the film shall be less than $1 \times 10^{-4}M$.

A1.3.5 Coating Flexibility—The coating shall be evaluated by bending three No. 19 [No. 6] coated steel reinforcing bars 6° (after rebound) around a 150-mm [6-in.] diameter mandrel. The bend shall be made at a uniform rate and completed within 5 s. The two longitudinal deformations shall be placed in a plane perpendicular to the mandrel radius. The specimens shall be between 20 and 30°C [68 and 86°F]. No cracking of the coating shall be discernible to a person with normal or corrected vision on the outside radius of any of the three bent bars.

A1.3.6 Relative Bond Strength in Concrete—The relative bond strength of the steel reinforcing bars to concrete shall be determined with beam-end specimens by the method described in Test Method **A944** using No. 19 [No. 6] steel reinforcing bars with a relative rib area (ratio of projected rib area normal to the bar axis to the product of the nominal bar perimeter and the center-to-center rib spacing) between 0.075 and 0.085. The bars shall be bottom-cast and shall have a cover of 40 ± 2 mm [1.5 ± 0.06 in.], a lead length of 13 ± 3 mm [0.5 ± 0.12 in.], and a bonded length of 250 ± 5 mm [10 ± 0.25 in.]. Test bars shall be oriented so that the longitudinal deformations and direction of rolling, relative to the direction of the applied tension, are the same for coated and uncoated bars. The test bars must be pulled in the same direction with respect to the direction of rolling. Three to six coated bar specimens and three to six uncoated bar specimens shall be tested. All steel reinforcing bars in a test group shall be from the same steel heat. The uncoated bars shall be cleaned only by lightly wiping with acetone or other suitable solvent. The mean bond strength of the coated bars shall not be less than 85 % of the mean bond strength of the uncoated bars.

A1.3.7 Abrasion Resistance—The resistance of the coating on each of three steel panels to abrasion by a Taber abraser (Test Method **D4060**) or its equivalent, using CS-10 wheels and a 1-kg [2.2-lb] load per wheel, shall be such that the weight loss shall not exceed 100 mg [0.0035 oz] after 1000 cycles.

A1.3.8 Impact Test—The resistance of the coating to mechanical damage shall be assessed by the falling weight test. A test apparatus similar to that described in Test Method **G14** shall be used along with a 16-mm [0.63-in.] tup. Impact shall occur on the low-lying areas on the coated bars, that is, between deformations or ribs. The test shall be performed at $24 \pm 2^\circ\text{C}$ [$75 \pm 3.6^\circ\text{F}$]. With an impact of 4.5 Nm [40 in.-lb], no shattering, cracking, or bond loss of the coating shall occur except at the impact area, that is, the area permanently deformed by the tup.

A1.4 Qualification Testing

A1.4.1 Testing Agency—Qualification tests shall be performed by an agency acceptable to the purchaser.

A1.5 Certification

A1.5.1 A report summarizing the results of all tests and bearing the signature of the testing laboratory shall be furnished to the manufacturer.