



Designation: **E164 – 08 E164 – 13**

## Standard Practice for Contact Ultrasonic Testing of Weldments<sup>1</sup>

This standard is issued under the fixed designation E164; the number immediately following the designation indicates the year of original adoption or, in the case of revision, the year of last revision. A number in parentheses indicates the year of last reappraisal. A superscript epsilon ( $\epsilon$ ) indicates an editorial change since the last revision or reappraisal.

*This standard has been approved for use by agencies of the Department of Defense.*

### 1. Scope—Scope\*

1.1 This practice covers techniques for the ultrasonic A-scan examination of specific weld configurations joining wrought ferrous or aluminum alloy materials to detect weld discontinuities ((see [Note 1](#)). The reflection method using pulsed waves is specified. Manual techniques are described employing contact of the search unit through a couplant film or water column.

1.2 This practice utilizes angle beams or straight beams, or both, depending upon the specific weld configurations. Practices for special geometries such as fillet welds and spot welds are not included. The practice is intended to be used on thicknesses of 0.250 to 8 in. (6.4 to 203 mm).

NOTE 1—This practice is based on experience with ferrous and aluminum alloys. Other metallic materials can be examined using this practice provided reference standards can be developed that demonstrate that the particular material and weld can be successfully penetrated by an ultrasonic beam.

NOTE 2—For additional pertinent information see Practice [E317](#), Terminology [E1316](#), and Practice [E587](#).

1.3 The values stated in inch-pound units are to be regarded as standard. The values given in parentheses are mathematical conversions to SI units that are provided for information only and are not considered standard.

1.4 *This standard does not purport to address all of the safety concerns, if any, associated with its use. It is the responsibility of the user of this standard to establish appropriate safety and health practices and determine the applicability of regulatory limitations prior to use.*

### 2. Referenced Documents

2.1 *ASTM Standards:*<sup>2</sup>

[E317 Practice for Evaluating Performance Characteristics of Ultrasonic Pulse-Echo Testing Instruments and Systems without the Use of Electronic Measurement Instruments](#)

[E543 Specification for Agencies Performing Nondestructive Testing](#)

[E587 Practice for Ultrasonic Angle-Beam Contact Testing](#)

[E1316 Terminology for Nondestructive Examinations](#)

2.2 *ASNT Document:*

[Recommended Practice SNT-TC-1A Personnel Qualification and Certification in Nondestructive Testing](#)<sup>3</sup>

2.3 *ANSI/ASNT Standard:*

[ANSI/ASNT CP-189 ASNT Standard for Qualification and Certification of Nondestructive Testing Personnel](#)<sup>3</sup>

2.4 *ISO Standard:*

[ISO 2400 Reference Block for the Calibration of Equipment for Ultrasonic Examination](#)<sup>4</sup>

2.5 *AIA Standard:*

[NAS-410 Certification and Qualification of Nondestructive Testing Personnel](#)<sup>5</sup>

### 3. Significance and Use

3.1 The techniques for ultrasonic examination of welds described in this practice are intended to provide a means of weld examination for both internal and surface discontinuities within the weld and the heat-affected zone. The practice is limited to the examination of specific weld geometries in wrought or forged material.

<sup>1</sup> This practice is under the jurisdiction of ASTM Committee [E07](#) on Nondestructive Testing and is the direct responsibility of Subcommittee [E07.06](#) on Ultrasonic Method. Current edition approved July 1, 2008; June 1, 2013. Published July 2008; June 2013. Originally approved in 1960. Last previous edition approved in 2003 as [E164 – 03: E164 – 08](#). DOI: [10.1520/E0164-08.10.1520/E0164-13](#).

<sup>2</sup> For referenced ASTM standards, visit the ASTM website, [www.astm.org](#), or contact ASTM Customer Service at [service@astm.org](#). For *Annual Book of ASTM Standards* volume information, refer to the standard's Document Summary page on the ASTM website.

<sup>3</sup> Available from The American Society for Nondestructive Testing (ASNT), P.O. Box 28518, 1711 Arlingate Ln., Columbus, OH 43228-0518.

<sup>4</sup> Available from American National Standards Institute (ANSI), 25 W. 43rd St., 4th Floor, New York, NY 10036.

<sup>5</sup> Available from Aerospace Industries Association of America, Inc. (AIA), 1000 Wilson Blvd., Suite 1700, Arlington, VA 22209-3928, [http://www.aia-aerospace.org](#).

\*A Summary of Changes section appears at the end of this standard

3.2 The techniques provide a practical method of weld examination for internal and surface discontinuities and are well suited to the task of in-process quality control. The practice is especially suited to the detection of discontinuities that present planar surfaces perpendicular to the sound beam. Other nondestructive examinations may be used when porosity and slag inclusions must be critically evaluated.

3.3 When ultrasonic examination is used as a basis of acceptance of welds, there should be agreement between the manufacturer and the purchaser as to the specific reference standards and limits to be used. Examples of reference standards are given in Section 7. A detailed procedure for weld examination describing allowable discontinuity limits should be written and agreed upon.

#### 4. Basis of Application

4.1 The following items are subject to contractual agreement between the parties using or referencing this standard.

4.1.1 *Personnel Qualification*—If specified in the contractual agreement, personnel performing examinations to this standard shall be qualified in accordance with a nationally or internationally recognized NDT personnel qualification practice or standard such as ANSI/ASNT CP-189, Recommended Practice SNT-TC-1A, NAS-410, or a similar document and certified by the employer or certifying agency, as applicable. The practice or standard used and its applicable revision shall be identified in the contractual agreement between the using parties.

4.1.2 *Qualification of Nondestructive Agencies*—If specified in the contractual agreement, NDT agencies shall be qualified and evaluated as described in E543. The applicable edition of E543 shall be specified in the contractual agreement.

4.1.3 *Procedures and Techniques*—The procedures and techniques to be utilized shall be as specified in the contractual agreement.

4.1.4 *Surface Preparation*—The pre-examination surface preparation criteria shall be in accordance with 78.1.28.1.2 unless otherwise specified.

4.1.5 *Timing of Examination*—The timing of examination shall be after weld completion and surface preparation and when the surface temperature has reached ambient temperature unless otherwise specified.

4.1.6 *Extent of Examination*—The extent of examination shall be in accordance with Table 2 unless otherwise specified.

4.1.7 *Reporting Criteria/Acceptance Criteria*—Reporting criteria for the examination results shall be in accordance with 12.1 unless otherwise specified. Since acceptance criteria are not specified in this standard, they shall be specified in the contractual agreement.

4.1.8 *Reexamination of Repaired/Reworked Items*—Reexamination of repaired/reworked items is not addressed in this standard and if required shall be specified in the contractual agreement.

#### 5. Search Units

5.1 Angle-Beam requirements for angle-beam search units are determined by the test variables. The examination procedure should be established by taking into consideration variables such as weld thickness, available surface, maximum allowable flaw size, flaw orientation, and the acoustic properties of the material. Consideration should also be given to the desirability of using comparable wave lengths within the materials where both a longitudinal-wave examination and an angle-beam shear-wave examination are employed. This can be accomplished by conducting the straight-beam (longitudinal-wave) examination at approximately two times the frequency of the angle-beam (shear-wave) examination.

5.2 Frequencies of 1.0 to 5 MHz are generally employed for angle-beam (shear-wave) and for straight-beam (longitudinal-wave) examination.

5.3 Transducer sizes recommended for weld examination range from a minimum of ¼-in. (6.4-mm) diameter or ¼-in. square to 1 in. (25.4 mm) square or 1½-in. (28.6-mm) diameter.

#### 6. Standardization

6.1 Two methods of angle-beam standardization are in general use: the polar, and the rectangular, coordinate methods.

6.1.1 The polar coordinate method requires measurements of the beam centerline at the search unit/work interface and the beam angle in a reference block, and the instrument sweep is standardized along the beam line. Test information is graphically converted into position and depth coordinates for reflector location. The polar method is detailed in Annex A1.

6.1.2 The rectangular coordinate method requires measurement of the position of the reflector from the front of the search unit, and the instrument sweep is standardized for depth to the reflector as it is moved to different positions in the beam providing a distance-amplitude curve. Test information is read directly for position and depth to the reflector. The rectangular coordinate method is detailed in Annex A2.

#### 7. Reference Standards

7.1 IIW-type reference blocks are a class of reference blocks for checking and standardizing ultrasonic instrumentation, which meet the basic geometrical configuration described in ISO 2400 but which may deviate in such aspects as non-metric dimensioning, alternate materials, additional reflectors, and differences of scale details. IIW-type blocks are primarily intended for characterizing and calibrating angle-beam systems, but also provide features for such uses as straight-beam resolution and sensitivity checks.

NOTE 3—Discussion of the differences among various versions of “IIW-Type” reference blocks, illustrations of typical configurations and an extensive bibliography can be found in a published reference.<sup>6</sup>

7.1.1 Only blocks fully meeting all the requirements of ISO 2400 should be referred to as IIW reference blocks.

7.1.2 Blocks qualified to certain other national standards may also satisfy all the requirements of ISO 2400 but have additional features.

7.1.3 The term *IIW Block Type I* should be used only to describe blocks meeting the standard cited. The term *IIW Block Type II* is reserved for the miniature angle-beam block recognized by ISO.

7.1.4 All other blocks derived from the basic ISO 2400 configuration, but not fully meeting all its requirements should be referred to as *IIW-Type* blocks.

7.1.5 Suppliers and users of such blocks should identify the specifications which are met, or provide detailed documentation.

7.1.6 Because of the possible differences noted, not all IIW-type blocks may be suited for every application for which qualified ISO 2400 blocks may be acceptable.

7.1.7 Unless the blocks have also been checked by prescribed ultrasonic procedures, they may also produce non-uniform or misleading results.

7.2 *Distance Standardization:*

7.2.1 An equal-radius reflecting surface subtending an arc of 90° is recommended for distance standardization because it is equally responsive to all beam angles. Other reflector configurations may be used. Equal-radius reflecting surfaces are incorporated into IIW-Type Blocks and several other reference blocks (see **Annex A1**) (**Note 3**). Distance standardization on a square-notch corner reflector with a depth of 1 to 3 % of thickness may be used. However, full beam reflections from the square corner of the block will produce erroneous results when standardizing angle beams near 60°, due to mode conversion. The square corner of the block should not be used for distance standardization.

NOTE 4—Small errors of beam index location are indigenous to the standardization procedure using the an IIW-Type Block. Where extremely accurate standardization is necessary, a procedure such as that outlined in 7.2.2 should be used.

7.2.2 For examination of welds, a side-drilled hole may be used for distance, amplitude, position, and depth standardization. An example is shown in **Fig. 1**. Move the reflector through the beam to 1/8, 3/8, 5/8, 7/8, and 9/8 of the Vee path. Adjust the delay to place indication 1 at sweep division 1. Adjust the range to place indication 9 at sweep division 9. Since these controls interact, repeat the delay and range adjustments until indications 1 and 9 are placed at sweep divisions 1 and 9. Adjust sensitivity to provide an 80 %-of-full-screen indication from the highest of the 1, 3, 5, 7, or 9 indications. At this sensitivity, mark the maximum amplitudes on the screen from the reflector at 1, 3, 5, 7, and 9. Connect these points for the distance amplitude curve (DA Curve). Corner reflections from the hole to the surface may be observed at 4 and 8 divisions on the sweep; these indications will not be used in the DA Curve. Measure the position of the reflector on the surface from the front of the search unit to the surface projection of the hole centerline. Since the depth to the hole is known, the standardization provides means for estimating the position, depth, and relative size of an unknown reflector.

7.3 *Sensitivity-Amplitude Standardization:*

7.3.1 Reference standards for sensitivity-amplitude standardization should be designed so that sensitivity does not vary with beam angle when angle-beam examination is used. Sensitivity-amplitude reference standards that accomplish this end are side-drilled holes parallel to the major surfaces of the plate and perpendicular to the sound path, flat-bottomed holes drilled at the examination angle, and equal-radius reflectors. Surface notches can also accomplish this end under some circumstances. These reference reflectors are described in **Table 1**.

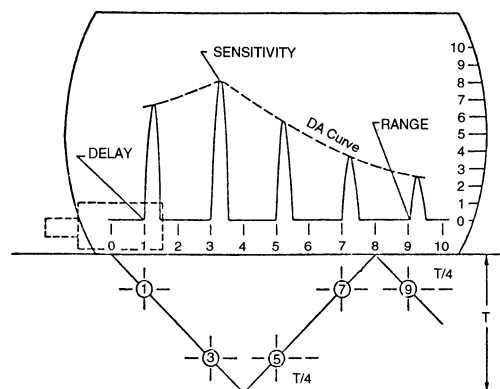

FIG. 1 Side-Drilled Hole

<sup>6</sup> Hotchkiss, F.H.C., “Guide to designs of IIW-type blocks”, *NDT International*, Vol. 23, n. 6, December 1990, pp. 319-331.

**TABLE 1 Reference Reflectors and Their Attributes**

Reference Reflector	Attributes and Limitations
Side-drilled holes	Easily manufactured and reproducible. Equally reflective to different beam angles. However, they bear negligible size relationship to most critical flaws.
Flat-bottom hole at examination angle	Difficult to manufacture and requires good angular agreement of drilled hole with examination angle.
Surface notches	Square notches simulate cracks at surface. V-notch half-angle should complement beam angle for maximum response.

7.3.2 Under certain circumstances, sensitivity-amplitude standardization must be corrected for coupling variations (Section 8) and distance amplitude effects (Section 9).

## 8. Coupling Conditions

### 8.1 Preparation:

8.1.1 Where accessible, prepare the surface of the deposited weld metal so that it merges into the surfaces of the adjacent base materials; however, the weld may be examined in the as-welded condition, provided the surface condition does not interfere with valid interpretation of indications.

8.1.2 Free the scanning surfaces on the base material of weld spatter, scale, dirt, rust, and any extreme roughness on each side of the weld for a distance equal to several times the thickness of the production material, this distance to be governed by the size of the search unit and refracted angle of the sound beam. Where scanning is to be performed along the top or across this weld, the weld reinforcement may be ground to provide a flat scanning surface. It is important to produce a surface that is as flat as possible. Generally, the surfaces do not require polishing; light sanding with a disk or belt sander will usually provide a satisfactory surface for examination.

8.1.3 The area of the base material through which the sound will travel in the angle-beam examination should be completely scanned with a straight-beam search unit to detect reflectors that might affect the interpretation of angle-beam results by obstructing the sound beam. Consideration must be given to these reflectors during interpretation of weld examination results, but their detection is not necessarily a basis for rejection of the base material.

### 8.2 Couplant:

8.2.1 A couplant, usually a liquid or semi-liquid, is required between the face of the search unit and the surface to permit transmission of the acoustic energy from the search unit to the material under examination. The couplant should wet the surfaces of the search unit and the piece, and eliminate any air space between the two. Typical couplants include water, oil, grease, glycerin, and cellulose gum. The couplant used should not be injurious to the material to be examined, should form a thin film, and, with the exception of water, should be used sparingly. When glycerin is used, a small amount of wetting agent is often added to improve the coupling properties. When water is used, it should be clean and de-aerated if possible. Inhibitors or wetting agents, or both, may be used.

8.2.2 The coupling medium should be selected so that its viscosity is appropriate for the surface finish of the material to be examined. The following list is presented as a guide:

Roughness Average (Ra $\mu\text{in.}$ )	Equivalent Couplant Viscosity
5 to 100	SAE 10 wt. motor oil
50 to 200	SAE 20 wt. motor oil
80 to 600	glycerin
100 to 400	SAE 30 wt. motor oil

8.2.3 In performing the examination, it is important that the same couplant, at the same temperature, be used for comparing the responses between the standardization blocks and the production material. Attenuation in couplants and wedge materials varies with temperature so that a standardization performed in a comfortable room is not valid for examination of either hotter or colder materials.

## 9. Distance-Amplitude Correction

9.1 Use standardization blocks of similar surface finish, nominal thickness and metallurgically similar in terms of alloy and thermal treatment to the weldment.

9.2 Alternative techniques of correction may be used provided the results are as reliable as those obtained by the acceptable method. In addition, the alternative technique and its equipment shall meet all the performance requirements of this standard.

### 9.3 Reference Reflectors:

9.3.1 *Straight-Beam Standardization*—Correction for straight-beam examination may be determined by means of a side-drilled hole reflector at  $\frac{1}{4}$  and  $\frac{3}{4}$  of the thickness. For thickness less than 2 in. (51 mm), the  $\frac{1}{4}$ -thickness reflector may not be resolved. If this is the case, drill another hole at  $\frac{1}{2}$  thickness and use the  $\frac{1}{2}$  and  $\frac{3}{4}$ -thickness reflectors for correction.

9.3.2 *Angle-Beam Standardization*—Correction for angle-beam examination may be determined by means of side-drilled hole reflectors at  $\frac{1}{4}$  and  $\frac{3}{4}$  of the thickness. The  $\frac{1}{2}$ -thickness depth to a side-drilled hole may be added to the standardization or used alone at thicknesses less than 1 in. (25.4 mm).

9.4 *Acceptable Techniques:*

9.4.1 *Distance-Amplitude Curve*—This method makes use of standardization blocks representing the minimum and maximum thickness to be examined. Additional standardization blocks of intermediate thicknesses can be used to obtain additional data points. The ultrasonic instrument, search unit, angle beam wedge, and couplant used for the distance-amplitude standardization must also be used for the weld examination.

9.4.1.1 Set the instrument to give an 80 % signal on the A-scan display from the highest amplitude obtained from the reference reflectors. Peak response from the other reference reflectors with the same instrument settings, and either record or mark on the screen the percent of screen height of the indication.

9.4.1.2 Then use these recorded percentages to draw a distance-amplitude curve of percent screen height versus depth or thickness on a chart or on the screen. During examination the distance amplitude curve may be used to estimate indication amplitude in percent of the DA Curve.

9.4.2 *Electronic Distance Amplitude Correction—Correction or Time-Corrected Gain*—This method can be used only if the instrument is provided with electronic distance amplitude compensation circuitry. Use is made of all reflectors in the standardization range. The equipment, search unit, couplant, etc., to be used in the ultrasonic examination are to be used for this attenuation adjustment.

9.4.2.1 Set the instrument to give a 50 % amplitude on the A-scan display from the reference reflector that gives the highest amplitude.

9.4.2.2 Peak the response from each reference reflector at other distances with the same instrument settings, adjusting the electronic distance amplitude correction controls to establish a 50 % screen height from the reference reflector at each successive thickness. Means of accomplishing the equalization of amplitude from equal-size reflectors over the distance range is best described for each instrument in the operating manual for that instrument.

10. Examination Procedures

10.1 Examination procedures recommended for common weld configurations are detailed in Table 2.

10.1.1 Special attention should be given to curved or contoured surfaces to ensure consistent ultrasonic beam entry angle and adequate coupling. Examine circumferential welds using Techniques 12 and 13 (Fig. 12 and Fig. 13); examine longitudinal welds using Techniques 14 and 15 (Fig. 14 and Fig. 15). Base choice of angle both on the radius of curvature and the thickness of the material in order to provide a beam that will travel through the material and reflect from the opposite surface.

10.1.2 When more than one technique is given for a particular weld geometry or thickness or both, the first technique is considered primary, while the additional techniques are supplementary and may be added to the examination procedure.

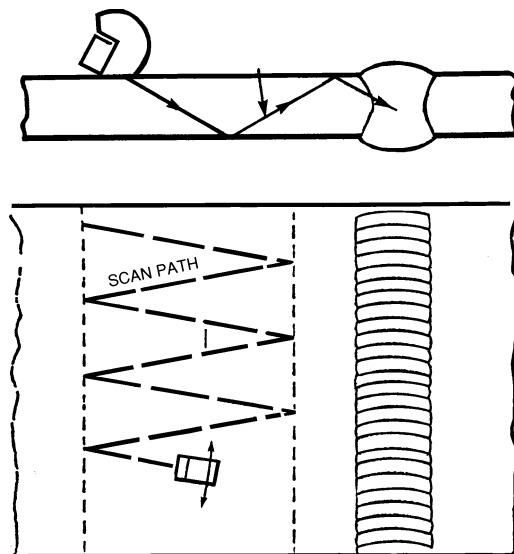

FIG. 2 Technique 1, for Examining Butt Welds with Angle Beams

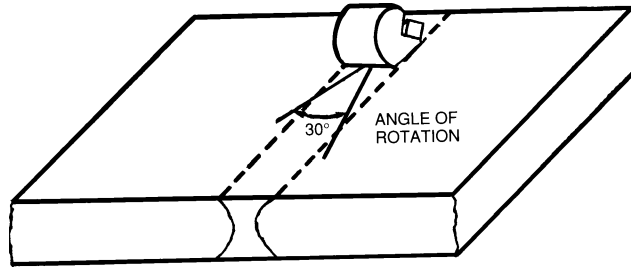

FIG. 3 Supplementary Technique 2, for Examining Butt Welds for Suspected Cross-Cracking when the Weld Bead is Ground Flush

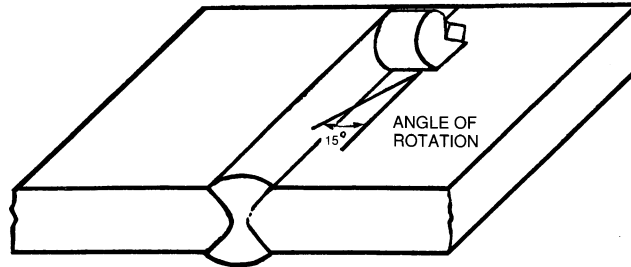

FIG. 4 Supplementary Technique 3, for Examining Butt Welds for Suspected Cross-Cracking when the Weld Bead is not Ground Flush

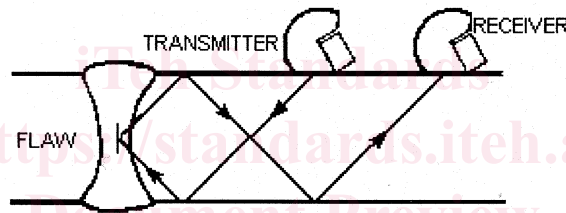

FIG. 5 Two-Search-Unit Technique 4, for Use with Thick Weldments

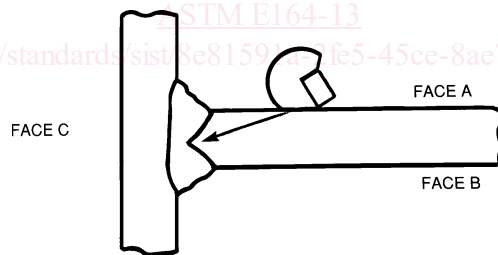

FIG. 6 Technique 5, for Examining the Weld Volume of T-Welds

11. Reflector Evaluation

11.1 Reflector Location—When distance standardization has been achieved in accordance with 7.1, approximate reflector location can be accomplished using the method of 7.1.2 or a chart of the type shown in Fig. 16.

11.2 Reflector Size and Orientation:

11.2.1 Geometrical Methods—Reflector length 1/4 in. (6.4 mm) minimum can be measured by determining the points at which half (6 dB) of the amplitude is lost at the extremities of the reflector and measuring between them. Reflector height 1/8 in. (3.2 mm) minimum can be measured by determining Δ SR (the change in sweep reading) at which half (6 dB) of the amplitude is lost as the search unit is moved to and from the reflector. The Δ SR × 100 divided by tSR (through thickness sweep reading) approximates the reflector height in percent of thickness. Only the area of the reflector that reflects energy to the search unit is measured. See Fig. 17. This method is appropriate for reflectors with dimensions greater than the beam diameter. For reflectors smaller than the beam, significant errors may occur.

11.2.2 Amplitude Methods—Signal amplitude can be used as a measure of flaw severity. Amplitude evaluation should be based upon experience with actual flaws since artificially produced reflectors are not always directly relatable to real flaw shapes or sizes. For adversely oriented planar flaws, the amplitude may not indicate flaw severity.

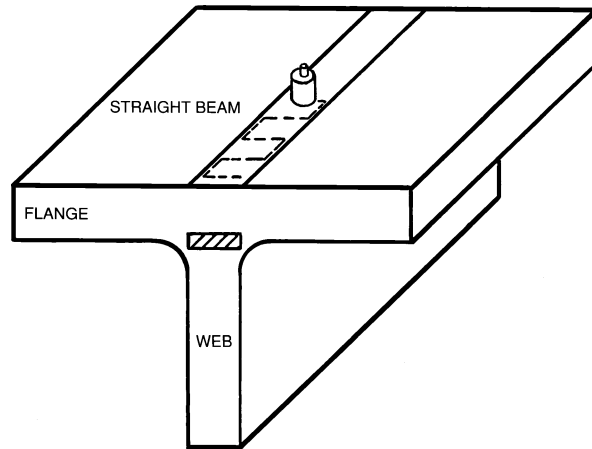
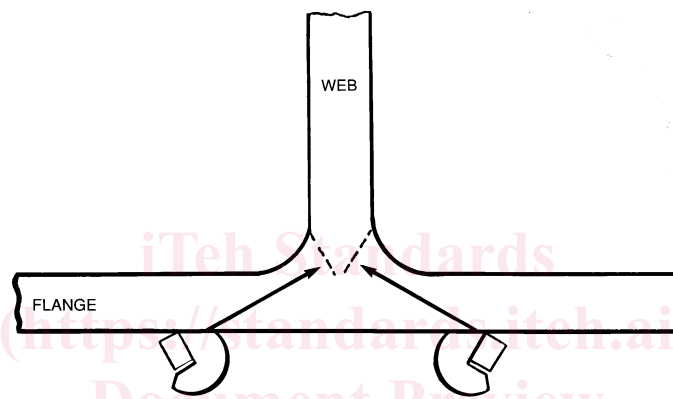

FIG. 7 Technique 6, for Examining the Fusion Zone of T-Welds



8(a) Technique 7, for Searching T-Welds for Discontinuities

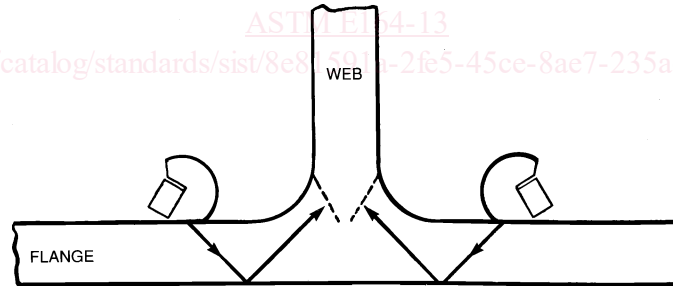

FIG. 8 (b) Alternative Technique 7, for Searching T-Welds for Discontinuities

11.3 *Reflector Type*—In addition to the evaluation of location and size of reflectors, there are several other attributes which can be used to identify other types of reflectors. It must be emphasized that these methods are dependent on operator skill to such a degree that acceptance of welds based upon this type of information alone is not recommended.

11.3.1 *Reflector Orientation*—Reflector orientation can be deduced from relative signal amplitudes obtained from the reflector with the search unit placed at various locations on the weldment. An example is shown in Fig. 18.

11.3.2 *Reflector Shape*—Reflector shape and roughness will result in a characteristic degree of sharpness of the A-scan display deflection depending upon the nature of the flaw, the instrument, and search-unit combination used.

**12. Report**

- 12.1 The contracting parties should determine the pertinent items to be recorded. This may include the following information:
  - 12.1.1 Weld types and configurations tested, including thickness dimensions. Descriptive sketches are usually recommended.
  - 12.1.2 Automatic flaw alarm or recording equipment or both, if used.
  - 12.1.3 Special search units, wedges, shoes, or saddles, if used.

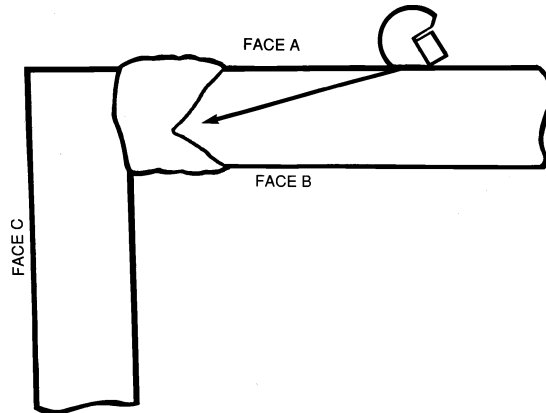

FIG. 9 Technique 8, for Examining the Weld Volume of Double-Vee Corner Welds

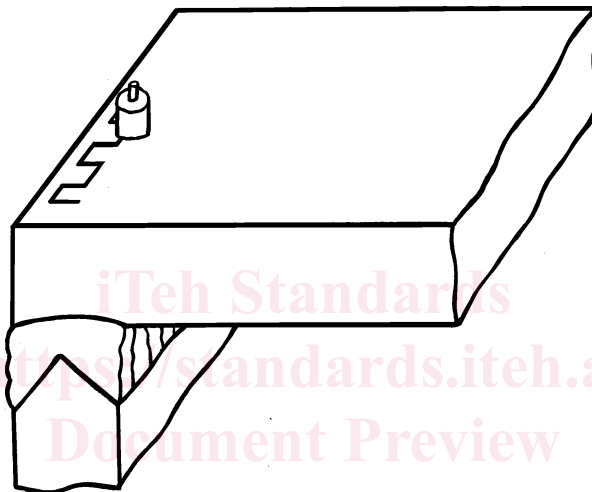

FIG. 10 Technique 9, for Examining the Fusion Zone of Double-Vee Corner Welds

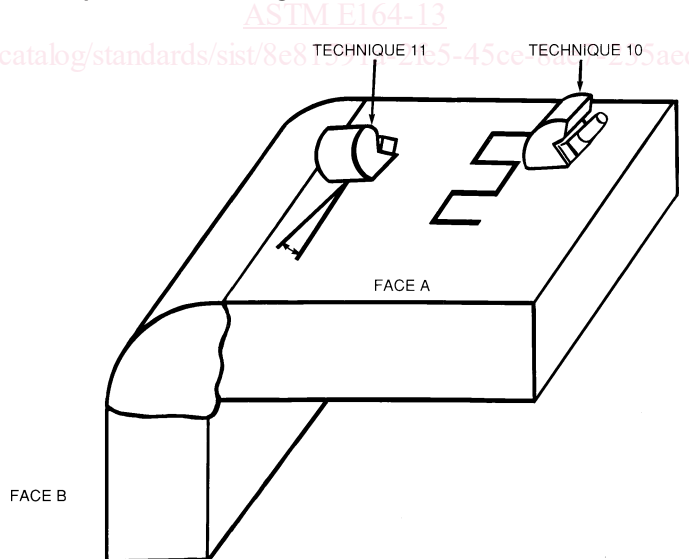

FIG. 11 Techniques 10 and 11, for Examining Full-Penetration Double-Fillet Corner Welds

- 12.1.4 Rotating, revolving scanning mechanisms, if used.
- 12.1.5 Stage of manufacture at which examination was made.
- 12.1.6 Surface or surfaces from which the examination was performed.
- 12.1.7 Surface finish.
- 12.1.8 Couplant.



**TABLE 2 Procedures Recommended for Common Weld Configurations**

Weld Type	Weld Throat Thickness									
	Less than ½ in. (12 mm)		½ to 1½ in. (12 to 38 mm)		1½ to 2½ in. (38 to 63 mm)		2½ to 5 in. (63 to 127 mm)		5 to 8 in. (127 to 200 mm)	
	Primary	Top ¼	Primary	Top ¼	Primary	Top ¼	Primary	Top ¼	Primary	Top ¼
<b>Butt:</b>										
Recommended angle, deg	70	70	70 or 60	45 or 60	70, 60, or 45	45 or 60	60 or 45	45 or 60	60 or 45	45
Suggested technique <sup>A</sup>	1, (2 or 3)	1	1, (2 or 3)	1	1, (2 or 3)	1	1, (2 or 3), 4	1	1, (2 or 3), 4	1
<b>Tee:</b>										
<b>Face A<sup>B</sup>:</b>										
Recommended angle, deg	70		70 or 60		70, 60, or 45		60 or 45		45	
Suggested technique	5		5		5		5, 4		5, 4	
<b>Face B<sup>B</sup>:</b>										
Recommended angle, deg	70		70 or 60		70, 60, or 45		60 or 45		45	
Suggested technique	5		5		5		5, 4		5, 4	
<b>Face C<sup>B</sup>:</b>										
Recommended angle, deg	straight, 70		straight (70 or 45)		straight, 45		straight, 45		straight, 45	
Suggested technique	6, 7		6, 7		6, 7		6, 7		6, 7	
<b>Corner:</b>										
<b>Face A<sup>C</sup>:</b>										
Recommended angle, deg	70		70 or 60		70, 60, or 45		60 or 45		45	
Suggested technique	8		8		8		8		8	
<b>Face B<sup>C</sup>:</b>										
Recommended angle, deg	70		70 or 60		70, 60, or 45		60 or 45		45	
Suggested technique	8		8		8		8		8	
<b>Face C<sup>C</sup>:</b>										
Recommended angle, deg	straight		straight		straight		straight		straight	
Suggested technique	9		9		9		9		9	
<b>Double Fillet Corner Weld:</b>										
<b>Face A<sup>D</sup>:</b>										
Recommended angle, deg	45		45		45		45		45	
Suggested technique	10, 11		10, 11		10, 11		10, 11		10, 11	
<b>Face B<sup>D</sup>:</b>										
Recommended angle, deg	45		45		45		45		45	
Suggested technique	10, 11		10, 11		10, 11		10, 11		10, 11	

**TABLE 2 Procedures Recommended for Common Weld Configurations**

Weld Type	Weld Throat Thickness									
	Less than ½ in. (12 mm)		½ to 1½ in. (12 to 38 mm)		1½ to 2½ in. (38 to 63 mm)		2½ to 5 in. (63 to 127 mm)		5 to 8 in. (127 to 200 mm)	
	Primary	Top ¼	Primary	Top ¼	Primary	Top ¼	Primary	Top ¼	Primary	Top ¼
<b>Butt:</b>										
Recommended angle, deg	70	70	70 or 60	45 or 60	70, 60, or 45	45 or 60	60 or 45	45 or 60	60 or 45	45
Suggested technique <sup>A</sup>	1, (2 or 3)	1	1, (2 or 3)	1	1, (2 or 3)	1	1, (2 or 3), 4	1	1, (2 or 3), 4	1
<b>Tee:</b>										
<b>Face A<sup>B</sup>:</b>										
Recommended angle, deg	70		70 or 60		70, 60, or 45		60 or 45		45	
Suggested technique	5		5		5		5, 4		5, 4	
<b>Face B<sup>B</sup>:</b>										
Recommended angle, deg	70		70 or 60		70, 60, or 45		60 or 45		45	
Suggested technique	5		5		5		5, 4		5, 4	
<b>Face C<sup>B</sup>:</b>										
Recommended angle, deg	straight, 70		straight (70 or 45)		straight, 45		straight, 45		straight, 45	
Suggested technique	6, 7		6, 7		6, 7		6, 7		6, 7	
<b>Corner:</b>										
<b>Face A<sup>C</sup>:</b>										
Recommended angle, deg	70		70 or 60		70, 60, or 45		60 or 45		45	
Suggested technique	8		8		8		8		8	
<b>Face B<sup>C</sup>:</b>										
Recommended angle, deg	70		70 or 60		70, 60, or 45		60 or 45		45	
Suggested technique	8		8		8		8		8	
<b>Face C<sup>C</sup>:</b>										
Recommended angle, deg	straight		straight		straight		straight		straight	
Suggested technique	9		9		9		9		9	
<b>Double Fillet Corner Weld:</b>										
<b>Face A<sup>D</sup>:</b>										
Recommended angle, deg	45		45		45		45		45	
Suggested technique	10, 11		10, 11		10, 11		10, 11		10, 11	
<b>Face B<sup>D</sup>:</b>										
Recommended angle, deg	45		45		45		45		45	
Suggested technique	10, 11		10, 11		10, 11		10, 11		10, 11	

<sup>A</sup> See Figs. Figs. 2-11 for illustration of the techniques listed below.

<sup>B</sup> Faces A, B, and C for tee welds are shown in Fig. 6.

<sup>C</sup> Faces A, B, and C for corner welds are shown in Fig. 9.

<sup>D</sup> Faces A and B for double fillet corner welds are shown in Fig. 11.

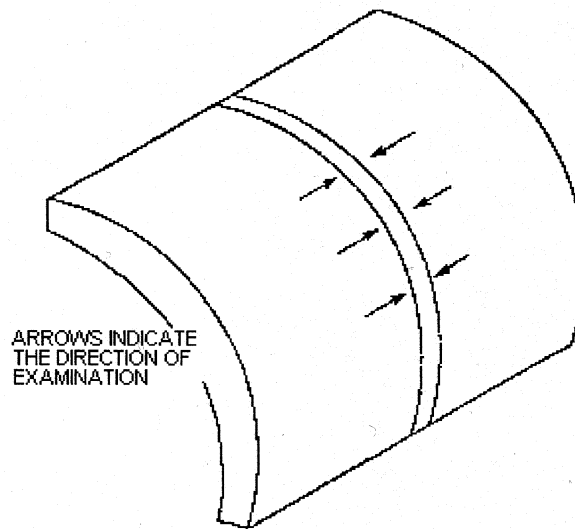

NOTE 1—Search-unit shoes are machined to match the curvature of the work piece when diameter is less than 20 in. (500 mm).

**FIG. 12 Technique 12, for Examining Circumferential Welds**

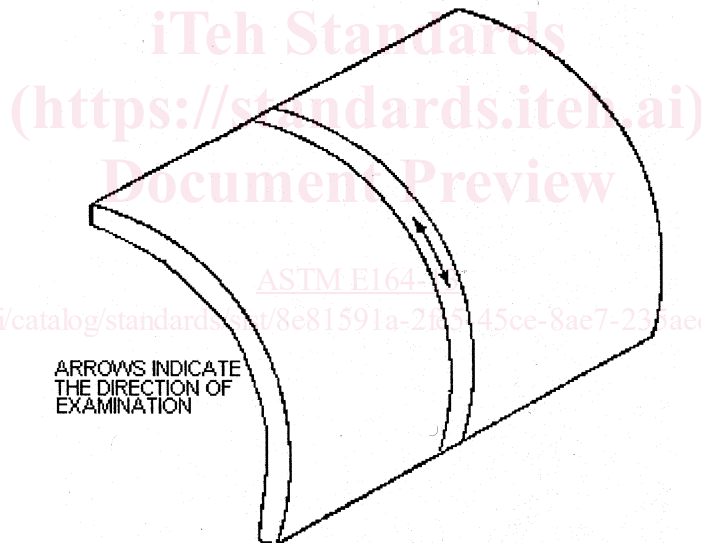

NOTE 1—Search-unit shoes are machined to match the curvature of the work piece when diameter is less than 20 in. (500 mm).

**FIG. 13 Supplementary Technique 13, for Examining Circumferential Welds, for Welds Ground Flush**

- 12.1.9 Method used.
- 12.1.10 Technique used.
- 12.1.11 Description of the standardization method and method of correlating indications with flaws.
- 12.1.12 Scanning parameters such as raster pitch and direction of beam.
- 12.1.13 Mode of transmission including longitudinal or shear, pulse-echo, tandem or through transmission.
- 12.1.14 Type and size of transducer.
- 12.1.15 Examination frequency.
- 12.1.16 Instrument identification information.
- 12.1.17 Flaw description (depth, location, length, height, amplitude, and character).
- 12.1.18 Name of operator.
- 12.1.19 Date of examination.

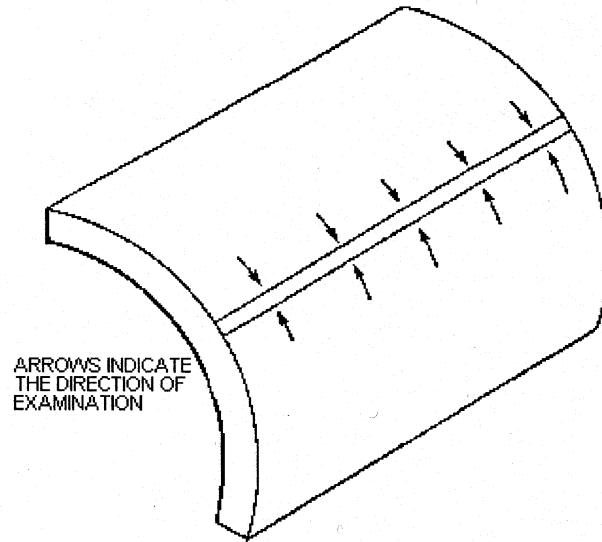

NOTE 1—Search-unit shoes are machined to match the curvature of the work piece when diameter is less than 20 in. (500 mm).

**FIG. 14 Technique 14, for Examining Longitudinal Welds**

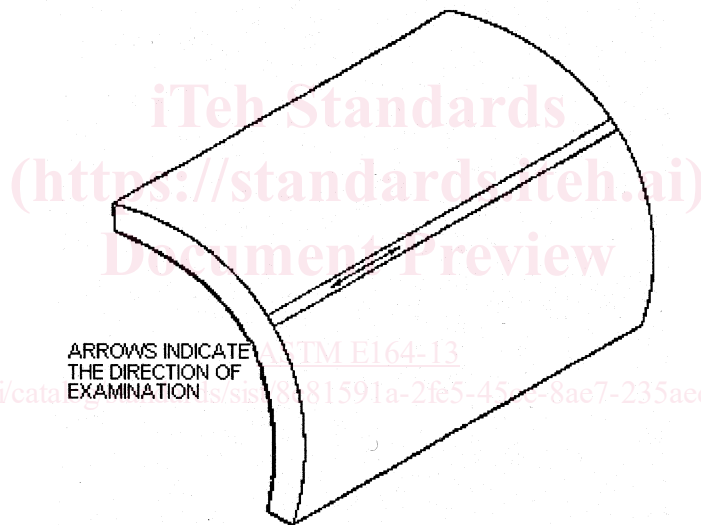

NOTE 1—Search-unit shoes are machined to match the curvature of the work piece when diameter is less than 20 in. (500 mm).

**FIG. 15 Supplementary Technique 15, for Examining Longitudinal Welds, for Welds Ground Flush**

### 13. Keywords

13.1 NDT of weldments; nondestructive testing; ultrasonic contact examination; ultrasonic NDT of weldments; weldments