



Designation: **B953—07 B953 – 13**

Standard Practice for Sampling Magnesium and Magnesium Alloys for Spectrochemical Analysis¹

This standard is issued under the fixed designation B953; the number immediately following the designation indicates the year of original adoption or, in the case of revision, the year of last revision. A number in parentheses indicates the year of last reapproval. A superscript epsilon (ϵ) indicates an editorial change since the last revision or reapproval.

1. Scope—Scope*

1.1 This practice describes the sampling of magnesium and magnesium-base alloys to obtain a chill-cast sample suitable for quantitative atomic emission spectrochemical analysis. The disk in the region to be excited is representative of the melt and gives a repeatability of results that approach that of the reference materials used.

1.2 This practice describes the procedure for representative sampling of molten metal.

1.3 The values stated in SI units are to be regarded as the standard. The values given in parentheses are for information only.

1.4 *This standard does not purport to address all of the safety concerns, if any, associated with its use. It is the responsibility of the user of this standard to establish appropriate safety and health practices and determine the applicability of regulatory limitations prior to use.* Specific precautionary statements are given in 5.1.

2. Referenced Documents

2.1 *ASTM Standards:*²

~~E401~~[B954 Practice for Bonding Thin Spectrochemical Samples and Standards to a Greater Mass of Material Test Method for Analysis of Magnesium and Magnesium Alloys by Atomic Emission Spectrometry \(Withdrawn 1995\)](#)

[B881 Terminology Relating to Aluminum- and Magnesium-Alloy Products](#)

[E135 Terminology Relating to Analytical Chemistry for Metals, Ores, and Related Materials](#)

[E1257 Guide for Evaluating Grinding Materials Used for Surface Preparation in Spectrochemical Analysis](#)

~~B954 Test Method for Analysis of Magnesium and Magnesium Alloys by Atomic Emission Spectrometry~~

3. Summary of Practice

3.1 Molten metal representative of the furnace melt is poured directly into a specified mold (described in 5.2.1) to produce a chill-cast disk. The disk is machined to a specific depth that represents the average melt composition and produces an acceptable surface for excitation.

3.2 Fabricated, cast, or wrought products may be excited directly without remelting; however, accuracy of results may suffer in highly alloyed samples due to the potential for elemental segregation.

4. Significance and Use

4.1 This practice, used in conjunction with the following quantitative atomic emission spectrochemical test method, [B954](#), is suitable for use in manufacturing control, material or product acceptance, certification, and research and development.

5. Apparatus

5.1 *Ladle*, capable of holding a minimum of 400 g (7.7 oz) of molten metal, with a handle of sufficient length to reach into a furnace, trough, or crucible sufficiently deep to obtain a sample representative of the melt being cast. The ladle may be lightly coated with a tightly adhering ladle wash that will not contaminate the sample. Boron nitride can be applied at elevated

¹ These practices are under the jurisdiction of ASTM Committee B07 on Light Metals and Alloys and are the direct responsibility of Subcommittee B07.04 on Magnesium Alloy Cast and Wrought Products.

Current edition approved June 1, 2007 May 1, 2013. Published July 2007 June 2013. Originally approved in 2007. Last previous edition approved in 2007 as B953 – 07. DOI: ~~10.1520/B0953-07~~10.1520/B0953-13.

² For referenced ASTM standards, visit the ASTM website, www.astm.org, or contact ASTM Customer Service at service@astm.org. For *Annual Book of ASTM Standards* volume information, refer to the standard's Document Summary page on the ASTM website.

*A Summary of Changes section appears at the end of this standard

temperatures to form a tenacious coating. **Warning**—Trace moisture in the coating or on the tool may cause dangerous spattering. Preheat all sampling tools and molds prior to use.

5.2 *Sample Molds*, capable of producing homogeneous chill-cast disks having smooth surfaces, free of surface pockets and porosity. These castings should have a spectrochemical response similar to the reference materials used in preparing the analytical curves and must have a repeatability from excitation-to-excitation of no more than 2% relative on major alloying elements. They must be representative of the melt in the region excited. Several types of molds have been found acceptable:

5.2.1 *Type A, open cavity mold*, is shown in Fig. 1. The advantage of this mold is its simple design and ability to produce a sample disk that can be excited around the entire annular area. Mold dimensions can be modified to produce a disk size ranging from approximately 44 to 64 mm (1.75 to 2.5 in.) in diameter by 10 to 15 mm (0.4 to 0.6 in.) in thickness. A circular central recess 10 to 20 mm (0.4 to 0.8 in.) in diameter on one side of the disk (analytical side) facilitates machining of that side in preparation for excitation. It also promotes a more uniform freezing of the raised peripheral area. The mold material should be mild steel and should weigh approximately 2 to 3 kg (4.5 to 6.5 lb).

5.2.2 *Type B, center pour mold*, is shown in Fig. 2. The advantage of this mold is that the sample obtained may be excited around the entire annular area. This mold produces a horizontally cast disk with the sprue over the center on the backside. The mold dimensions are such as to produce a disk approximately 64 mm (2.5 in.) in diameter by 13 mm (0.5 in.) in thickness. A circular central recess 10 to 13 mm (0.4 to 0.5 in.) in diameter on one side of the disk (analytical side) facilitates machining of that side in preparation for excitation. It also promotes more uniform freezing of the raised peripheral area, but the corresponding raised portion of the mold must not be so large as to restrict the throat for the sprue. A slight taper, 1 to 2°, on the hinged portion of the mold facilitates opening when a disk has been cast. The mold material should be mild steel and should weigh approximately 3.5 to 4.5 kg (8 to 10 lb).

5.2.3 *Type U, U-Block mold*, is shown in Fig. 3. This side gated block mold produces a cylindrical block sample of approximately 40 mm (1.6 in.) in diameter by 60 mm (2.4 in.) high. The mold is placed on top of a massive 150 mm (5.9 in.) diameter by 50 mm (2.0 in.) thick copper chill plate with a knurled working surface. The mold material is mild steel. The downsprue directionally choked side gate promotes a controlled fill. The strong directional solidification provided by the chill plate produces a spectrochemically homogenous sample for at least the first third and usually up to two thirds of the length of the U-block sample from chill the cast face (Note 1).

NOTE 1—To improve the performance and durability of the molds described above, prepare the surface of the mold cavity to minimize the formation of gas pockets on the surface of the castings and to resist rusting of the mold cavity surface. To do this, blast the inner surface with a sharp grit that cuts rather than peens. The resulting finely roughened face is essential for obtaining a smooth and uniform surface on the cast disk. Next, degrease the mold, place in a cold furnace, and raise the temperature to 400°C (752°F). At this temperature and throughout the remainder of the heating cycle, introduce steam into the furnace. Raise the temperature to 540°C (1004°F) and maintain for 4 h. The resulting black oxide coating is tenacious and of a dull black appearance.

5.2.4 *Other Types of Molds*—Other molds of different types, materials, and dimensions may be substituted provided that the uniformity of the samples so obtained is comparable to the uniformity of samples obtained from the Type A, B, or U molds, and furthermore that such samples have a spectrochemical response similar to the reference materials used for preparing the analytical curve.

5.3 *Lathe*, capable of machining a smooth, flat surface on the reference materials and samples. A milling machine may also be used.

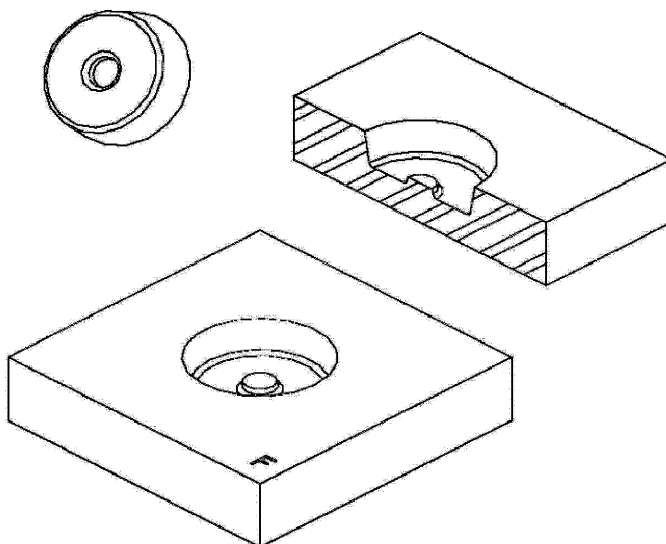

FIG. 1 Type A Mold – Open Cavity Mold and Sample