



Designation: G6 – 07 (Reapproved 2013)

Standard Test Method for Abrasion Resistance of Pipeline Coatings¹

This standard is issued under the fixed designation G6; the number immediately following the designation indicates the year of original adoption or, in the case of revision, the year of last revision. A number in parentheses indicates the year of last reapproval. A superscript epsilon (ϵ) indicates an editorial change since the last revision or reapproval.

1. Scope

1.1 This test method of accelerated test is a procedure for determining the relative resistance of steel pipeline coatings to abrasion by a slurry of coarse abrasive and water. The method is intended to apply to the testing of all types of electrical insulating pipeline coatings and tapes, including thermoplastics, thermoset, and bituminous materials.

1.2 Pipeline coatings are not normally subjected to the type of abrasion herein specified.

1.3 Metallic protective coatings such as zinc may be compared visually, but do not meet the electrical requirements of this test method.

1.4 The values stated in SI units to three significant decimals are to be regarded as the standard. The values given in parentheses are for information only.

1.5 *This standard does not purport to address all of the safety concerns, if any, associated with its use. It is the responsibility of the user of this standard to establish appropriate safety and health practices and determine the applicability of regulatory limitations prior to use.*

2. Referenced Documents

2.1 *ASTM Standards:*²

G12 Test Method for Nondestructive Measurement of Film Thickness of Pipeline Coatings on Steel (Withdrawn 2013)³

G62 Test Methods for Holiday Detection in Pipeline Coatings

3. Terminology

3.1 *Definitions:*

¹ This test method is under the jurisdiction of ASTM Committee D01 on Paint and Related Coatings, Materials, and Applications and is the direct responsibility of Subcommittee D01.48 on Durability of Pipeline Coating and Linings.

Current edition approved June 1, 2013. Published June 2013. Originally approved in 1969. Last previous edition approved in 2007 as G6–07. DOI: 10.1520/G0006-07R13.

² For referenced ASTM standards, visit the ASTM website, www.astm.org, or contact ASTM Customer Service at service@astm.org. For *Annual Book of ASTM Standards* volume information, refer to the standard's Document Summary page on the ASTM website.

³ The last approved version of this historical standard is referenced on www.astm.org.

3.1.1 *holidays, n*—small faults or pinholes which permit current drainage through protective coatings on steel pipe.

4. Summary of Test Method

4.1 Apparatus and materials are described whereby coatings on steel pipe are worn away by an abrasive slurry contained in a horizontally revolving drum. Specimens extend through both ends of the drum and are electrically insulated from contact with the test apparatus.

4.2 Periodic measurement of the electrical resistance between the specimen and the drum indicates the degree of abrasion resistance of the coating.

5. Significance and Use

5.1 This procedure defines a test method for comparing the relative resistance of pipeline coatings to abrasion.

5.2 Abrasion resistance may be used to specify optimum coating thickness of candidate materials both in development and research work to study new coating systems or methods and in quality control.

6. Apparatus

6.1 *Drum*—A cylindrical steel container suitable for testing nine specimens simultaneously. **Figs. 1-3** show construction details which may be altered at the cap assembly if desired. A valve shall be provided to release any pressure built up during test.

6.2 *Apparatus for Revolving the Drum*—Any suitable apparatus used to revolve the drum at 30.48 m (100 linear ft)/min. A modified jar rolling mill⁴ has been found satisfactory for revolving the drum.

6.3 *Thickness Gage*, to be used in accordance with Test Method **G12**.

6.4 *Holiday Detectors*, low-voltage wet-sponge type for thin film coatings (coatings thinner than 20 mils), and high-voltage type for thick film coatings (coatings thicker than 20 mils).

⁴ The sole source of supply known to the committee at this time, to provide a means for revolving the drum is Figure 801-V Jar Mill available from U.S. Stoneware, Inc., Akron, OH. If you are aware of alternative suppliers, please provide this information to ASTM Headquarters. Your comments will receive careful consideration at a meeting of the responsible technical committee, ¹ which you may attend.

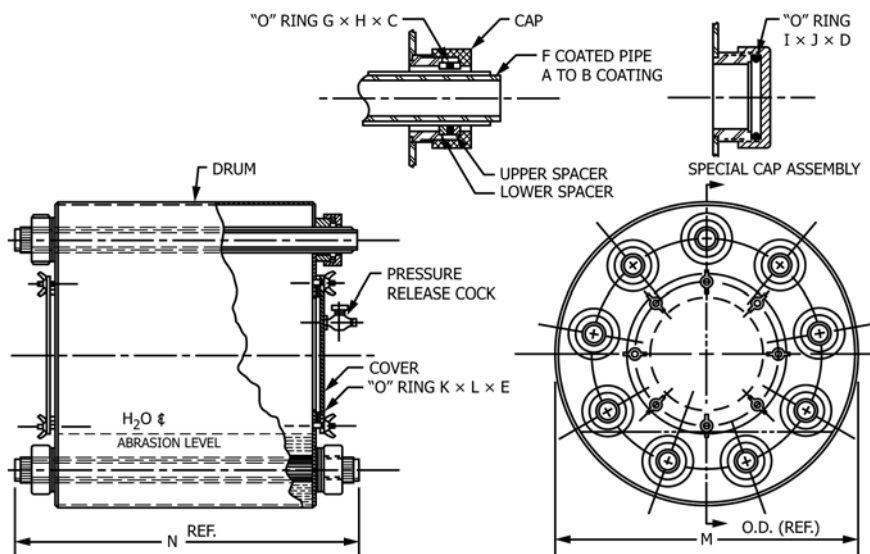

Dimensions for Fig. 1:

Symbol	mm	in.
A	0.15	0.006
B	2.28	0.090
C	3.17	0.125
D	4.76	0.188
E	6.35	0.250
F	19.05	0.750
G	25.40	1.000
H	31.75	1.125
I	38.10	1.500
J	47.63	1.875
K	136.53	5.375
L	149.23	5.875
M	355.6	14.0
N	406.4	16.0

NOTE 1—Estimated weight includes water and abrasive 39.5 kg (87 lb).

FIG. 1 Abrasion-Tester Assembly

NOTE 1—Low voltage detectors are used to locate pinholes, voids, or thin spots in pipeline coatings. The potential used with wet-sponge detectors can be up to 100 V DC. Procedures for using these detectors are found in Method A of G62. For use of high voltage detectors operating in the 900 to 20 000 Vdc range, see Method B of G62.

6.5 Volt-ohm-meter—Any electrical test instrument for measuring electrical resistance of the circuit.

7. Reagents and Materials

7.1 The test slurry shall consist of the following:

7.1.1 Aluminum Oxide Grit, ⁵ 13.6 kg (30 lb).

7.1.2 Tap Water; 5.68 L (1½ gal).

8. Test Specimen

8.1 A 19.1 mm test specimen 406 mm (16 in.) long shall be prepared with its surface preparation and coating procedures equivalent to that of production coated pipe. Only holiday-free specimens, in duplicate, shall be used in this test.

⁵ The sole source of supply of aluminum oxide abrasive, No. 3 mesh, Type TA, untumbled, known to the committee at this time is Exolon Co., Tonawanda, NY 14150. If you are aware of alternative suppliers, please provide this information to ASTM Headquarters. Your comments will receive careful consideration at a meeting of the responsible technical committee,¹ which you may attend.

8.2 Control specimens shall be included in each test, the selection of which is optional with the user.

9. Conditioning

9.1 The specimen shall be exposed to a room temperature of 21 to 25°C (70 to 77°F) for a period of 24 h before beginning the test.

10. Procedure

10.1 Perform the test at a room temperature of 21 to 25°C (70 to 77°F).

10.2 Measure and record the coating thickness of each specimen in accordance with Test Method G12.

10.3 Check all specimens or holidays using an appropriate detector.

10.4 Position the specimens in the drum taking care not to damage the coating.

10.5 Load the apparatus with 13.6 kg (30 lb) of unused abrasive and 5.68 L (1½ gal) of water.

10.6 Test each specimen for electrical resistance after sealing the drum by using the volt-ohm-meter. Immerse the