



Standard Test Method for Burst Testing of Flexible Package Seals Using Internal Air Pressurization Within Restraining Plates¹

This standard is issued under the fixed designation **F2054/F2054M**; the number immediately following the designation indicates the year of original adoption or, in the case of revision, the year of last revision. A number in parentheses indicates the year of last reapproval. A superscript epsilon (ϵ) indicates an editorial change since the last revision or reapproval.

1. Scope

1.1 These test methods cover the procedure for determining the minimum burst strength of a seal placed around the perimeter of a flexible package as it is internally pressurized and enclosed within restraining plates.

1.2 The test methods described herein are functionally similar to Test Methods **F1140** with the exception of the use of restraining plates. Test Methods **F1140** describes methods of burst testing that do not include the use of restraining plates and are suitable to determine a packages general ability to withstand pressurization stresses. Under Test Methods **F1140** the stresses are not distributed uniformly to all areas of the package seal. Under unrestrained conditions the stress on the package is highest at the middle of the pouch where it inflates to the packages maximum diameter; therefore, Test Methods **F1140** may not reliably detect the weakest area of the seal.

1.3 The burst test internally and increasingly pressurizes a package until an area of the package seal around the perimeter “bursts” open in response to pressurization. By placing the package within restraining plates during pressurization, the dimensional stability of the package is maintained in a manner that results in stresses applied more uniformly along the perimeter of the package, where seals are normally placed. This allows the test to have a higher probability of detecting the weakest area of the seal and provide a measurement of the pressure required to “burst” open the package.

1.4 This test only applies to flexible packages with seals placed around the perimeter of a flexible package (often referred to as a pouch). In particular it is intended as applicable to packages with seals that have a peelable seal feature (peeled open by end user to remove contents of package).

1.4.1 Porous barrier materials’ failure to reach adequate pressure to burst the package seals may be due to insufficient volume flow. See **Appendix X4** for information.

1.5 The values stated in either SI units or inch-pound units are to be regarded separately as standard. The values stated in each system may not be exact equivalents; therefore, each system shall be used independently of the other. Combining values from the two systems may result in non-conformance with the standard.

1.6 *This standard does not purport to address all of the safety concerns, if any, associated with its use. It is the responsibility of the user of this standard to establish appropriate safety and health practices and determine the applicability of regulatory limitations prior to use.* Particular caution is advised where users of this procedure may be required to design and fabricate restraining plate fixtures. Reference **Appendix X3** for further information regarding calculation of stress factors and structural design considerations.

2. Referenced Documents

2.1 ASTM Standards:²

- ~~D1898E171 Practice for Sampling of Plastics Conditioning and Testing Flexible Barrier Packaging (Withdrawn 1998)~~
- ~~D4332 Practice for Conditioning Containers, Packages, or Packaging Components for Testing~~
- E691 Practice for Conducting an Interlaboratory Study to Determine the Precision of a Test Method
- F17 Terminology Relating to Flexible Barrier Packaging
- F88 Test Method for Seal Strength of Flexible Barrier Materials

¹ This test method is under the jurisdiction of ASTM Committee **F02** on Flexible Barrier Packaging and is the direct responsibility of Subcommittee **F02.20** on Physical Properties.

Current edition approved Nov. 1, 2012/April 1, 2013. Published November 2012/June 2013. Originally approved in 2000. Last previous edition approved in 2007/2012 as **F2054 – 07/F2054 – 07 (2012)**. DOI: ~~10.1520/F2054-07R12~~10.1520/F2054_F2054M-13.

² For referenced ASTM standards, visit the ASTM website, www.astm.org, or contact ASTM Customer Service at service@astm.org. For *Annual Book of ASTM Standards* volume information, refer to the standard’s Document Summary page on the ASTM website.

F1140 Test Methods for Internal Pressurization Failure Resistance of Unrestrained Packages
 F1327 Terminology Relating to Barrier Materials for Medical Packaging (Withdrawn 2007)³

3. Terminology

3.1 *Definitions*—For definitions and terms used in this test method, see refer to Terminology F1327F17; for standardized terminology for flexible barrier packaging.

3.2 *Definitions of Terms Specific to This Standard:*

3.2.1 *flexible package or pouch, n*—refers to a package in which at least one of the sealed materials is of a flexible structure (that is, paper, polyethylene, and so forth):

3.2.1 *restraining plates, n*—refers to plates that are rigid in nature and configured to contact and limit the packages expandable surface area as the package is pressurized.

4. Summary of Test Method

4.1 Packages are tested in an apparatus that internally pressurizes the package until an area of the package ruptures (burst). For most applications the rupture (burst) will occur at one or more areas of the seal. The pneumatic supply and pressurization equipment need the capability to maintain an increasing pressure until the seal area fails. (For porous barrier material, see Appendix X4.) During pressurization, the package shall be enclosed between two rigid and parallel plates (restraining plates) that limit the expansion and dimensional distortion of the package but allow the seal perimeter area to be unrestricted. A sensor inside the package detects the internal pressure at the point at which the package ruptures (burst). Dependent on the application, two configurations of restraining plates are indicated for use with this test method. Generally, these are described as follows:

4.1.1 *Open Package Configuration* —An open package configuration is used where there is a seal placed around three sides of the package perimeter and the fourth side is open. This configuration is generally used in the original package manufacture. See Fig. 1 for an illustration of the configuration used.

4.1.2 *Closed Package Configuration* —A closed package configuration is used where there is a seal placed around all four sides of the package. This configuration generally is used in operations where the purpose is to test the seal in it's finished, fully-sealed state. See Fig. 2 for an illustration of the configuration used.

5. Significance and Use

5.1 This test provides a rapid means of evaluating tendencies for package seal failure when the package is exposed to a pressure differential. Pressure differentials may occur during such processes as sterilization and transportation. This test method provides an indicator of the burst strength of a package, where the burst will normally occur in one or more areas of the seal. An indicator of the minimum burst strength may be of importance to the package manufacturer and end user in ensuring adequate package integrity. This test method cannot provide a measure of package seal uniformity. This test method also cannot provide an evaluation of overall package integrity or the burst strength of areas of the package that contact the surface of the restraining plates used. This test method should be combined with other methods of evaluating overall package integrity, uniformity of the package seal, or opening functionality, if so required.

5.2 This test frequently is used to quickly evaluate package seal strength during the manufacturing process and at various stages of the package's life cycle.

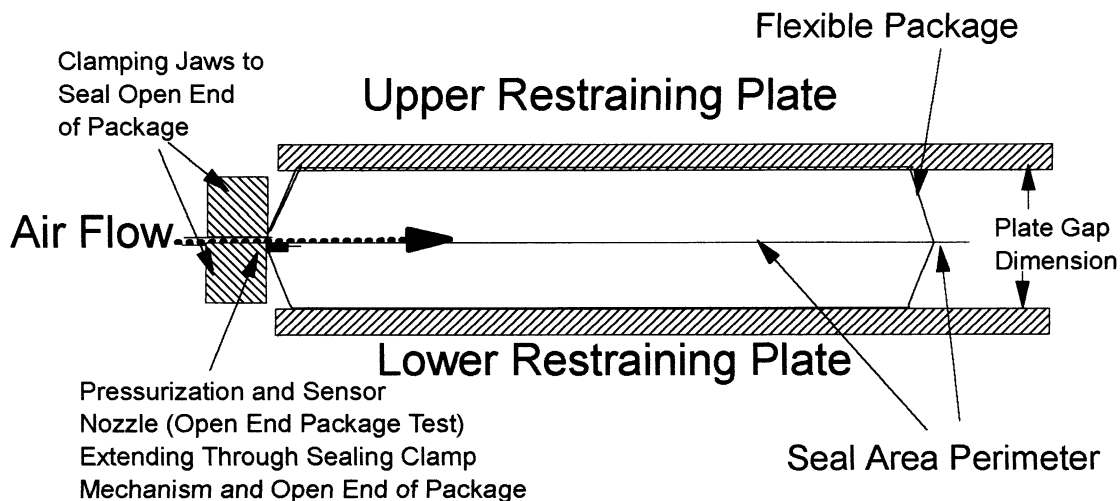

FIG. 1 Restraining Plates, Open Package Configuration

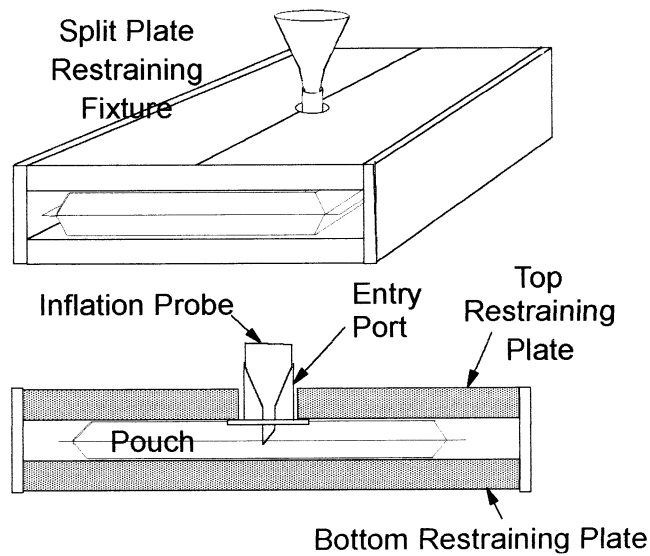

FIG. 2 Restraining Plates, Closed Package Configuration

5.3 If correlations between pieces of test equipment are to be made it is important that all parameters of the test be equivalent. Typical parameters can include, but are not limited to the package size, material, type and configuration of seal, rate of air flow into the package, pressure detection sensing mechanism and sensitivity (machine response to pressure drop), position of test article, rigidity of restraining plates, and distance between restraining plates. See [Appendix X2](#) for further information.

5.4 This test may not necessarily provide correlation with package seal strength as typically measured using Test Methods [F1140](#) or [F88](#) (or equivalents).

6. Apparatus

6.1 Packages are tested under conditions described as follows:

6.1.1 *Open-Package Tester*—Open-package test fixtures are used to test flexible packages with one of the four sides of the package open (nonsealed). The package is pressurized with an inflation nozzle and pressure sensing mechanism inserted into the open end of the package. The open end then is sealed by a clamping mechanism for the duration of the test (see [Fig. 1](#)).

6.1.2 *Closed-Package Tester*—Closed-package test fixtures are used to test packages with all four sides of the package sealed. The closed package tester internally pressurizes the package utilizing a pressure nozzle and sensing mechanism that is connected through a puncture in the package (see [Fig. 2](#)).

6.2 The test apparatus for both open and closed package testing shall include the following:

6.2.1 An air supply and pressure regulating mechanism that can produce sufficient air flow to pressurize the package to the point of package failure (burst); for porous barrier materials, see [Appendix X4](#);

6.2.2 A means of detecting a rapid pressure drop inside the package that signals that an area of the package is stressed to failure (burst);

6.2.3 A means of measuring the internal pressure at the point in which a rapid pressure drop occurs as the result of seal or other package failure (burst);

6.2.4 Two restraining plates that are configured similar to as shown in [Fig. 1](#) or [Fig. 2](#), is rigid to movement and flex, and contact the expandable surface area of the package for the duration of the test.

6.2.5 The following depending on type of test conducted.

6.2.5.1 Open-package test fixtures shall have a pressurization nozzle and sensor that is inserted into the open end of the package, and a clamping mechanism that seals the open end of the package, as well as creates an air tight seal around the pressurization nozzle and sensor; and

6.2.5.2 Closed-package test fixtures shall have a pressurization nozzle and sensor that inserts into a puncture of the body of the sealed package while maintaining an air tight seal around those mechanisms.

7. Sampling

7.1 *Sampling*—Choose the number of test specimens to permit an adequate determination of representative performance. Practice [D1898](#) provides guidance to test specimen selection.



8. Conditioning

8.1 *Standard Test Conditions*—Condition and test package under standard laboratory atmosphere of $73.4^{\circ} \pm 2^{\circ}\text{F}$ ($23^{\circ} \pm 1^{\circ}\text{C}$) and $50 \pm 2\%$ relative humidity. Condition the packages for a minimum of 72 h before performing testing test. Reference Practice Specification D4332E171 for further information on standard conditioning.

8.2 Effects of environmental conditions other than the above standards have not been determined as they relate to the results of this test method and may depend on packaging materials used. Where comparisons or correlation's of test results may be a requirement, and the test is conducted in other than standard test conditions, record the conditioning factors and the temperature and relative humidity at the time of test.

9. Procedure

9.1 *Package Preparation*—The package may be tested with, if the package can fit within the restraining plates, or without product enclosed inside the package. Record the package test preparation, if applicable.

9.2 *Open-Package Test:*

9.2.1 Insert the package in a manner in which the body of the package is enclosed between the restraining plates. Place the package between the restraining plates in a manner which minimizes the unrestrained areas of the package during the test. It is advised to use some type of markings or fixturing that ensures consistent placement for all packages tested. Ensure plate gap dimension is set to appropriate gap setting. See [Appendix X1](#) for recommendations on determining appropriate plate gap dimension settings.

9.2.2 Insert or otherwise place the pressurization and sensor nozzle inside the open end of the package.

9.2.3 Close the clamping mechanism to produce an air tight seal around the open end of the package including the area around the pressurization and sensor nozzle.

9.3 *Closed-Package Test:*

9.3.1 Insert the body of the package within the restraining plates and close the plates, if applicable, to the required plate gap dimension. See [Appendix X1](#) for recommendations on determining appropriate plate gap dimension settings.

9.3.2 Carefully insert the pressurization and sensor nozzle entry device, and affix to the package so as to create an air tight seal. The center of the package is the preferred point of entry and may be fixtured as an attachment to the restraining plates (see [Fig. 2](#)).

9.4 Set the rate of pressurization and sensor sensitivity, if user selectable. Set the pressure failure sensor readout, if user selectable, to the desired units of measure, usually set to readout in pascal (Pa), kilopascal kPa), or inches of water units of measure for most package test resolutions required.

9.5 Begin test by initiating inflation process. Continue pressurization until a failure occurs. A failure in this context is when an area of the package ruptures (bursts) as the result of pressurization. The rupture (burst) is detected by the sensing mechanism as a rapid decrease in pressure within the body of the package, and the pressure reading device reports the pressure at the point in time just prior to the pressure drop.

9.6 Visually examine the tested package and note the position and type of failure, as well as the pressure at which the failure occurred. If the failure occurred in an area other than the seal the test may be voided depending on the purpose of the investigation.

10. Report

10.1 The report should include or have traceability to the following:

10.1.1 Test performed (open or closed package), apparatus used, test device machine settings chosen if operator adjustable (rate of pressurization and sensitivity of pressure drop detection sensor), gap distance between restraining plates, and blocking agent used (see [Appendix X4](#)).

10.1.2 Packaging material types and other characteristics of package tested, that is, whether with or without package contents inside the package, seal type and configuration, etc., package lot number and source's name.

10.2 Include the date, time, location, and identification of the individual performing the test. The number of packages tested, the individual test values, and the units of measure that the sensing device is set to return as response values. Documentation also may include notations of failure mode, area of seal package failure, unusual test conditions and results.

10.3 The conditioning parameters and environmental conditions used at the time of test, if applicable.

10.4 A summary including comments or conclusions, the sample mean and standard deviation, should also be reported where appropriate.

11. Precision and Bias

11.1 A research report³ describes a round robin conducted in 1999 in accordance with Practice E691, involving ten laboratories testing four package sets for each of two material types. Materials tested are listed in Table 1⁴ and statistical results are listed in Table 2 and Table 3. All samples were prepared at one source and then distributed to each of the laboratories participating in the study. Each laboratory performed ten replicate tests for each package set. All testing was conducted using restraining plates set to a gap height of 25.4 mm. Only the open package test configuration (see Figs. 1 and 2) was used for the round robin, precision is assumed to be similar for both open and closed package test configurations.

11.2 *Limitations and Considerations* —The test methods described herein are destructive in nature and do not allow repeat measurements on any given test specimen; therefore, by definition repeatability and reproducibility cannot be assessed as independent of the variability of the materials tested. Any estimate of test method precision in terms of repeatability or reproducibility will include some level of variability attributable to the materials used. In addition, the selection of test parameters (flow rate, plate gap height, pressure drop sensor sensitivity, etc.) for any given package configuration (package size, materials used, bonding agents, seal area configuration, skirt area, etc.) will impact test results in terms of observed measurement values. Caution is advised where comparing test results conducted for different materials or test parameters.

11.3 Repeatability and reproducibility statistics in Table 2 include estimates of variance (standard deviations) and coefficients of variation (COV). Table 3 lists a summary of results which are average COVs for all package sets. Measurement units are in kilopascal (kPa). COVs are included based on the observation that the variability generally increases in proportion to the mean for any given set of test values. This relationship may or may not apply to other materials or materials tested at test parameters other than used for this study. Also included are estimates based on the standard deviations of the laboratory to laboratory (between laboratory) averages. This is included for the user to consider as an alternative estimate of test method reproducibility from laboratory to laboratory.

11.4 *Bias*—There are no recognized standards by which to estimate the bias of this test method.

12. Keywords

12.1 burst; closed-package; flexible packaging; inflation; medical packaging; open package; restraining plate method

iTech Standards
(<https://standards.itih.ai>)
Document Preview

[ASTM F2054/F2054M-13](https://standards.itih.ai/catalog/standards/sist/63790b2f-b17e-4b51-812b-ed2af1f772e9/astm-f2054-f2054m-13)

<https://standards.itih.ai/catalog/standards/sist/63790b2f-b17e-4b51-812b-ed2af1f772e9/astm-f2054-f2054m-13>

³ Supporting data have been filed at ASTM International Headquarters and may be obtained by requesting Research Report RR:F02-1014.

⁴ Tyvek is a registered trademark of DuPont.

TABLE 1 Descriptions of Package Sets Tested in Round-Robin Study

Package Set	Package ID	Dimensions and Material Configurations ^A	Number of Samples	
			Tested per Lab	Number of Labs
A	158.8 mm × 295.3 mm	Spunbonded Olefin: PET/PE	10	10
B	139.7 mm × 231.8 mm	Spunbonded Olefin: PET/PE	10	10
C	183.9 mm × 276.2 mm	Spunbonded Olefin: PET/PE	10	10
D	133.4 mm × 224.8 mm	Spunbonded Olefin: PET/PE	10	10
E	171.5 mm × 301.6 mm	Paper: PET/PE	10	10
F	171.5 mm × 301.6 mm	Paper: PET/PE	10	10
G	114.3 mm × 222.3 mm	Paper: PET/PE	10	10
H	235.0 mm × 350.9 mm	Paper: PET/PE	10	10

^AAll dimensions provided are nominal dimensions of width× length in millimeters, measured as internal dimensions from seal to seal within the packages tested. All packages tested are medical grade peelable seal pouches with 15 degree chevron style seal configuration. Materials listed are spunbonded olefin (1073B grade Tyvek) or medical grade paper sealed to PET/PE (polyester/polyethylene) or PET/PP (polyester/polypropylene) laminated structures.³

**TABLE 2 Summary of Interlaboratory Test Results by Package Set**

Package Set	Average kPa	Standard Deviation of Lab to Lab Averages,		Within Lab Repeatability Standard Deviation,		Between Lab Reproducibility Standard Deviation,	
		kPa	COV%	kPa	COV%	kPa	COV%
A	14.78	0.7221	4.89 %	1.3931	9.43 %	1.5060	10.19 %
B	18.58	1.5550	8.37 %	1.8825	10.13 %	2.3660	12.73 %
C	17.73	1.1346	6.40 %	1.5945	8.99 %	1.8910	10.66 %
D	15.73	0.8591	5.46 %	2.7499	17.48 %	2.7499	17.48 %
E	10.54	0.6198	5.88 %	0.8477	8.04 %	1.0153	9.63 %
F	9.06	0.8294	9.16 %	0.5974	6.60 %	1.0045	11.09 %
G	12.17	1.2560	10.32 %	1.5828	13.01 %	1.9576	16.09 %
H	8.84	0.4847	5.48 %	0.4197	4.75 %	0.6273	7.10 %

TABLE 3 Summary of Interlaboratory Test Results, Average COV for all Materials

Coefficient of Variation Basis	Average Value, %
Lab to lab averages	6.99
Within lab repeatability	9.80
Between lab reproducibility	11.87

APPENDIXES

(Nonmandatory Information)

X1. RECOMMENDATIONS FOR DETERMINING PLATE GAP DIMENSION

X1.1 **Table X1.1** lists recommended maximum plate gap dimensions for varying package sizes as based on the rationale described in **X1.3**. Other plate gap dimensions may be used depending on the application and suitable rationale for their usage. Experimentation with plate gap settings should be conducted for any specific application to determine suitability for use. Selection of a gap dimension may be dependent on materials tested, or bonding mechanism, or both, as well as geometry of the seal. A pilot test of pouches at two or three gap dimensions, which can be correlated to seal strength tests (see Test Method **F88**) to locate the weakest area of the pouch seal perimeter can guide user to select that gap, which provides the most consistency of indicating the weakest seal area. The rationale and recommendations described in the following sections are to be considered a guideline to use as a starting point for plate gap selection.

X1.2 As a precautionary warning regarding safety, it should be noted that reductions in plate gap dimensions will result in higher stresses acting upon the plates for any given package size and design. This should be factored into the structural design of any restraining plates. Reference **Appendix X3** for further information regarding calculation of stress factors and structural design considerations.

X1.3 The rationale for recommended plate gap dimensions as listed in **Table X1.1** is based on ensuring that a minimum of 60 % of the inflated package surface area fully contacts the plate surface. This is intended to ensure that the package is maintained in a state of restraint when fully inflated. Conceptually a very small gap dimension could be considered ideal for a given range of package sizes. Available data indicates that the plate gap should be minimized where possible. Ideally 90 % or more of the inflated

TABLE X1.1 Recommended Plate Gap Dimensions

X Package Seal to Seal Dimension (Minimum of Width or Length)	D Restraining Plate Maximum Gap Dimension	Z Minimum % of Inflated Package Surface in Contact with Restraining Plates
≥ 101.6 mm	25.5 mm	≥60.73 %
≥ 50.8 mm to < 101.6 mm	12.7 mm	≥60.73 %
≥25.4 mm to < 50.8 mm	6.5 mm	≥60.73 %