



Designation: **C652—12a C652 – 13**

Standard Specification for Hollow Brick (Hollow Masonry Units Made From Clay or Shale)¹

This standard is issued under the fixed designation C652; the number immediately following the designation indicates the year of original adoption or, in the case of revision, the year of last revision. A number in parentheses indicates the year of last reapproval. A superscript epsilon (ϵ) indicates an editorial change since the last revision or reapproval.

This standard has been approved for use by agencies of the Department of Defense.

1. Scope*

1.1 This specification covers hollow building brick and hollow facing brick made from clay, shale, fire clay, or mixtures thereof, and fired to incipient fusion. Four types of hollow brick in each of two grades and two classes are covered. In this specification, the term hollow brick shall be understood to mean hollow clay masonry units whose net cross-sectional area (solid area) in any plane parallel to the surface, containing the cores, cells, or deep frogs, is less than 75 % of its gross cross-sectional area measured in the same plane (see 4.3). This specification does not cover brick intended for use as paving brick (see Specification C902).

1.2 The property requirements of this specification apply at the time of purchase. The use of results from testing of brick extracted from masonry structures for determining conformance or nonconformance to the property requirements (Section 6) of this standard is beyond the scope of this specification.

1.3 Brick covered by this specification are ceramic products manufactured primarily from clay, shale, or similar naturally occurring substances and subjected to a heat treatment at elevated temperatures (firing). The heat treatment shall develop sufficient fired bond between the particulate constituents to provide the strength and durability requirements of this specification. Additives or recycled materials are permitted to be included at the option of the manufacturer. (See “firing” and “firing bond” in Terminology C1232.)

1.3.1 This specification and its individual requirements shall not be used to qualify or corroborate the performance of a masonry unit made from other materials, or made with other forming methods, or other means of binding the materials.

1.4 Hollow brick differ from unglazed structural clay tile (Specifications C34 and C212) and solid brick (Specifications C62 and C216). Hollow brick require greater shell and web thicknesses and higher minimum compressive strength than structural clay tile, but permit greater void area and lesser distance from exposed edge to core hole than solid brick. Therefore, environmental and structural performance may be different in elements constructed of hollow brick from those constructed of structural clay tile or solid brick.

1.5 The text of this specification references notes and footnotes which provide explanatory material. These notes and footnotes (excluding those in tables and figures) shall not be considered as requirements of the specification.

1.6 The values stated in inch-pound units are to be regarded as standard. The values given in parentheses are mathematical conversions to SI units that are provided for information only and are not considered standard.

2. Referenced Documents

2.1 ASTM Standards:²

- C34 Specification for Structural Clay Load-Bearing Wall Tile
- C62 Specification for Building Brick (Solid Masonry Units Made From Clay or Shale)
- C67 Test Methods for Sampling and Testing Brick and Structural Clay Tile
- C212 Specification for Structural Clay Facing Tile
- C216 Specification for Facing Brick (Solid Masonry Units Made from Clay or Shale)
- C902 Specification for Pedestrian and Light Traffic Paving Brick

¹ This specification is under the jurisdiction of ASTM Committee C15 on Manufactured Masonry Units and is the direct responsibility of Subcommittee C15.02 on Brick and Structural Clay Tile.

Current edition approved Dec. 1, 2012; June 1, 2013. Published January 2013; June 2013. Originally approved in 1970. Last previous edition approved in 2012 as C652—12; C652 – 12a. DOI: 10.1520/C0652-12A; 10.1520/C0652-13.

² For referenced ASTM standards, visit the ASTM website, www.astm.org, or contact ASTM Customer Service at service@astm.org. For Annual Book of ASTM Standards volume information, refer to the standard's Document Summary page on the ASTM website.

*A Summary of Changes section appears at the end of this standard

3. Terminology

3.1 *Definitions*—For definitions relating to masonry and hollow brick, refer to Terminology C1232.

4. Classification

4.1 *Grades*—Two grades of hollow brick are covered:

4.1.1 *Grade SW*—Hollow brick intended for use where a high and uniform degree of resistance to frost action and disintegration by weathering is desired and the exposure is such that the hollow brick may be frozen when permeated with water.

4.1.2 *Grade MW*—Hollow brick intended for use where a moderate and somewhat nonuniform degree of resistance to frost action is permissible or where they are unlikely to be permeated with water when exposed to temperatures below freezing.

4.2 *Types*—Four types of hollow brick are covered:

4.2.1 *Type HBS*—Hollow brick for general use in masonry.

4.2.2 *Type HBX*—Hollow brick for general use in masonry where a higher degree of precision and lower permissible variation in size than permitted for Type HBS is required.

4.2.3 *Type HBA*—Hollow brick for general use in masonry selected to produce characteristic architectural effects resulting from nonuniformity in size and texture of the individual units.

4.2.4 *Type HBB*—Hollow brick for general use in masonry where a particular color, texture, finish, uniformity, or limits on cracks, warpage, or other imperfections detracting from the appearance are not a consideration.

4.2.5 When the type is not specified, the requirements for Type HBS shall govern.

4.3 *Class*—Two classes of hollow brick are covered:

4.3.1 *Class H40V*—Hollow brick intended for use where void areas or spaces greater than 25 %, but not greater than 40 %, of the gross cross-sectional area of the unit measured in any plane parallel to the surface containing the cores, cells, or deep frogs are desired. The void spaces, the web thicknesses, and the shell thicknesses shall comply with the requirements of Section 10 on Coring and Frogging.

4.3.2 *Class H60V*—Hollow brick intended for use where larger void areas are desired. The sum of these void areas shall be greater than 40 %, but not greater than 60 %, of the gross cross-sectional area of the unit measured in any plane parallel to the surface containing the cores, cells or deep frogs. The void spaces, the web thicknesses, and the shell thicknesses shall comply with the requirements of Section 10 on Coring and Frogging and to the minimum requirements contained in Table 1 (see Fig. 1).

4.3.3 When the class is not specified, the requirements of Class H40V shall govern.

5. Materials and Manufacture

5.1 The body of all hollow brick shall be of clay, shale, fire clay, or mixtures of these materials, with or without admixtures, burned to meet the requirements of this specification. Any coloring or other materials added to the clay shall be suitable ceramic materials and shall be well distributed throughout the body.

5.2 Colors and textures produced by application of inorganic coatings to the faces of the brick shall be permitted with the consent of the purchaser, provided that evidence is furnished of the durability of the coatings. Brick that are colored by flashing or textured by sanding, where the sand does not form a continuous coating, shall not be considered as surface-colored brick for the purpose of this specification.

NOTE 1—When surface colored brick, other than sanded or flashed, are specified for *exterior* use, the purchaser should require that data be submitted showing that after 50 cycles of freezing thawing there is no observable difference in the applied finish when viewed from a distance of 10 ft (3.0 m) under an illumination of not less than 50 ft-candles (538 lx) by an observer with normal vision.

Service records of the performance of the particular coated brick in exterior locations may be accepted in place of the freezing and thawing test, upon consent of the purchaser.

³ The last approved version of this historical standard is referenced on www.astm.org.

TABLE 1 Class H60V—Hollow Brick Minimum Thickness of Face Shells and Webs, in. (mm)

Nominal Width of Units	Face Shell Thicknesses		End Shells or End Webs
	Solid	Cored or Double Shell	
3 and 4 (76 and 101)	¾ (19.05)	...	¾ (19.05)
6 (152)	1 (25.4)	1½ (38)	1 (25.4)
8 (203)	1¼ (32)	1½ (38)	1 (25.4)
10 (254)	1⅝ (35)	1⅝ (41)	1⅝ (29.5)
12 (306)	1½ (38)	2 (50)	1⅝ (29.5)

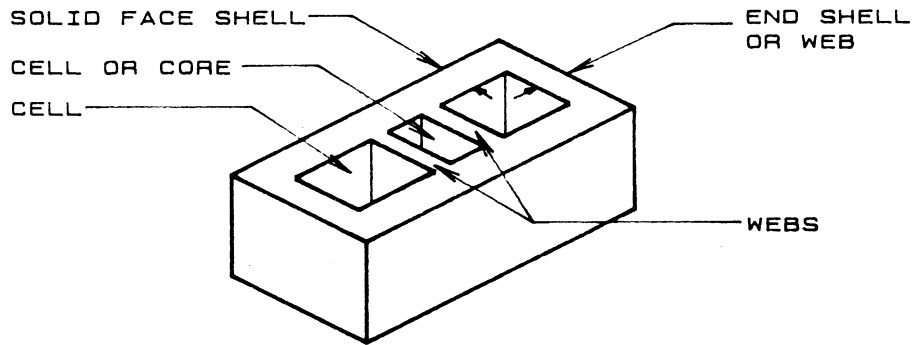

SOLID SHELL HOLLOW BRICK UNITS

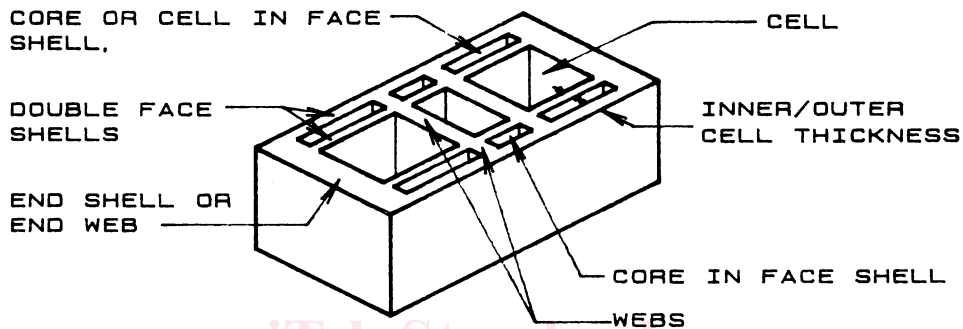

DOUBLE SHELL HOLLOW BRICK UNITS

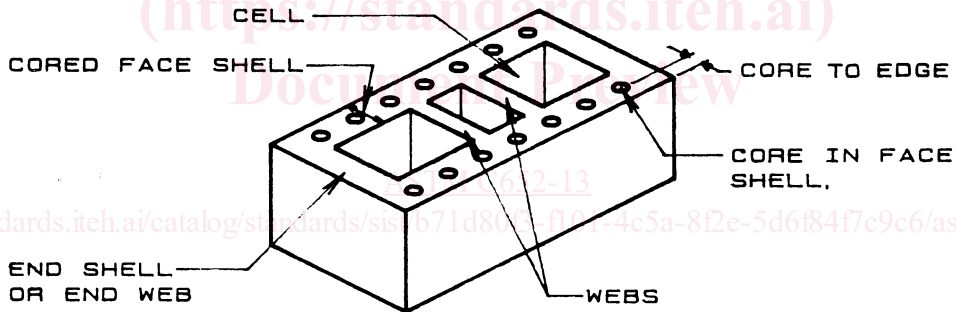

CORED SHELL HOLLOW BRICK UNITS

FOR MINIMUM DIMENSIONS SEE SECTION 10 AND TABLE 1

FIG. 1 Hollow Brick Units

5.3 The brick shall be free of defects, deficiencies, and surface treatments, including coatings, that would interfere with the proper laying of the brick or significantly impair the strength or performance of the construction.

5.4 If any post-firing coatings or surface treatments are applied by the manufacturer, the manufacturer shall report the type and extent of these coatings or surface treatments in all certificates of compliance with this specification.

6. Physical Properties

6.1 *Durability*—When grade is not specified, the requirements for Grade SW shall govern.

6.1.1 *Physical Property Requirements*—The brick shall conform to the physical requirements for the grade specified as prescribed in **Table 2**. For the compressive strength requirements in **Table 2**, test the unit with the compressive force perpendicular to the bed surface of the unit, with the unit in the stretcher position.

6.1.2 *Absorption Alternate*—The saturation coefficient requirement does not apply, provided that the 24-h cold water absorption of each of the five units tested does not exceed 8.0 %.

6.1.3 *Freezing and Thawing Alternative*—The requirements for 5-h boiling water absorption and saturation coefficient do not apply, provided a sample of five brick, meeting the strength requirements of **Table 2**, passes the freezing and thawing test as described in the Rating Section of the Freezing and Thawing test procedures of Test Methods **C67**.

TABLE 2 Physical Requirements

Designation	Compressive Strength gross area, min, psi (MPa)		Water Absorption by 5-h Boiling, max, %		Saturation Coefficient, max	
	Average of 5 brick	Individual	Average of 5 brick	Individual	Average of 5 brick	Individual
	Grade SW	3000 (20.7)	2500 (17.2)	17.0	20.0	0.78
Grade MW	2500 (17.2)	2200 (15.2)	22.0	25.0	0.88	0.90

NOTE 2—The 50-cycle freezing and thawing test is used as an alternative only when the brick do not conform to either Table 2 requirements for maximum water absorption and saturation coefficient, or to the requirements of the Absorption Alternate in 6.1.2.

6.1.3.1 Grade SW: Breakage and Weight Loss Requirement—No individual unit separates or disintegrates resulting in a weight loss greater than 0.5 % of its original dry weight.

6.1.3.2 Grade SW: Cracking Requirement—No individual unit develops a crack that exceeds, in length, the unit’s least dimension.

6.1.4 Low Weathering Index Alternative:

6.1.4.1 If the brick are intended for use exposed to weather where the weathering index is less than 50 (see Fig. 2), and unless otherwise specified, the requirements given in Table 2 for 5-h boiling water absorption and for saturation coefficient shall not apply, but the minimum average compressive strength requirement of 2500 psi (17.2 MPa) shall apply.

NOTE 3—The effect of weathering on brick is related to the weathering index, which for any locality is the product of the average annual number of

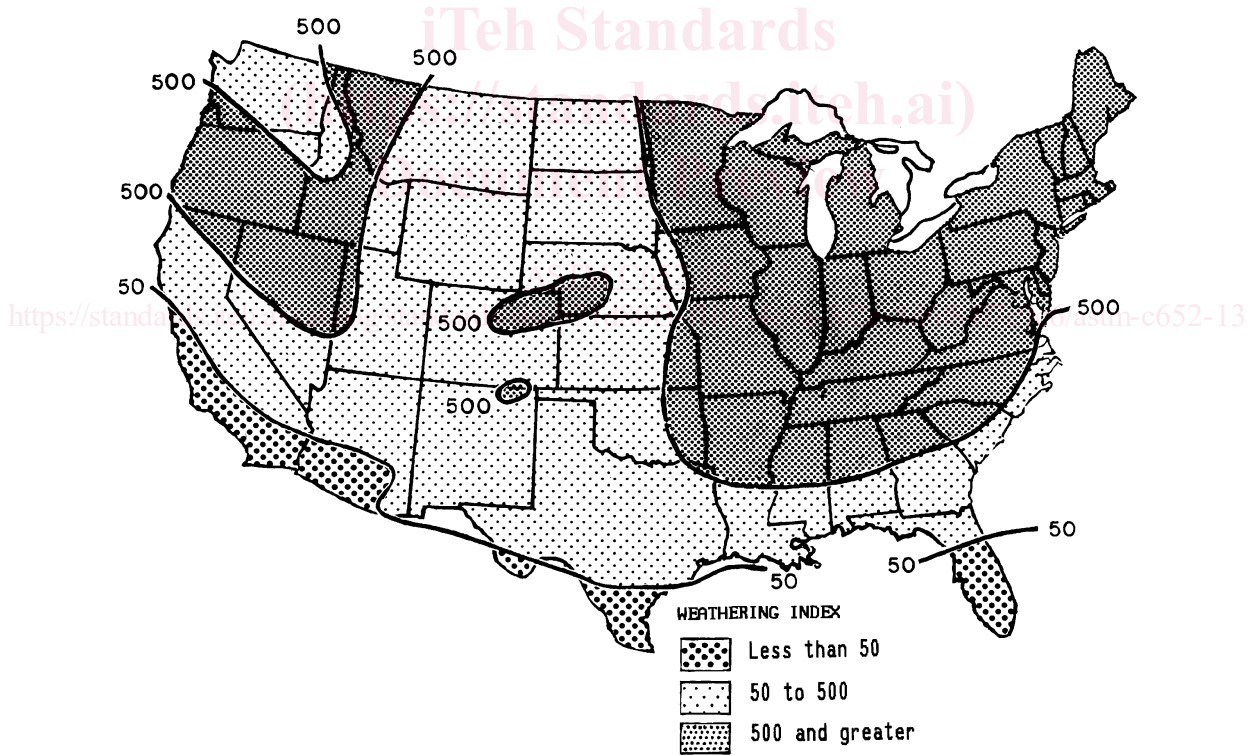

Grade Recommendations for Face Exposures

Exposure	Weathering Index (Note 3)	
	Less than 50	50 and greater
In vertical surfaces:		
In contact with earth	SW or MW	SW
Not in contact with earth	SW or MW	SW
In other than vertical surfaces:		
In contact with earth	SW	SW
Not in contact with earth	SW or MW	SW

FIG. 2 Weathering Indices in the United States