



Designation: D7568 – 13

# Standard Specification for Polyethylene-Based Structural-Grade Plastic Lumber for Outdoor Applications<sup>1</sup>

This standard is issued under the fixed designation D7568; the number immediately following the designation indicates the year of original adoption or, in the case of revision, the year of last revision. A number in parentheses indicates the year of last reapproval. A superscript epsilon ( $\epsilon$ ) indicates an editorial change since the last revision or reapproval.

## 1. Scope

1.1 This specification covers a type of plastic lumber product, defined as polyethylene-based structural-grade plastic lumber (SGPL), for use as main framing members, including joists, stringers, beams, columns; and secondary framing members, including planking, posts and bracing; in outdoor structures such as decks, boardwalks, docks, and platforms.

1.2 This specification is applicable to solid, rectangular SGPL products where polyethylene resin (non cross-linked) is the continuous phase and is at least 50 % of the product (by weight).

1.3 This specification is not applicable to plastic lumber products containing cellulosic materials as additives, fillers or fiber reinforcements.

1.4 SGPL products covered by this specification shall not be used as tensile members.

1.5 SGPL products are produced using several different manufacturing processes. These processes utilize a number of polyethylene resin material systems that include varying proportions of fillers, fiber reinforcements, and other chemical additives.

1.6 Due to thermodynamic effects that result in outer-surface densification during manufacture, SGPL products are typically non-homogeneous in the cross-section. This standard does not address materials that have been modified from their original cross-section.

1.6.1 The cross-section non-homogeneity is addressed in the material property assessments in this document only for applications in which the product cross-section is not modified by cutting, notching, or drilling. For products modified in this manner, additional engineering considerations are required and they are beyond the scope of this document.

1.7 For purposes of this standard, an SGPL product is a specific combination of polyethylene resin, together with

fillers, reinforcements, and additives. Each formulation is to be identified as a distinct and different product, to be tested and evaluated separately.

1.8 Diverse and multiple combinations of both virgin and recycled polyethylene material systems are permitted in the manufacture of SGPL products.

1.9 Fiber reinforcements used in SGPL include manufactured materials such as fiberglass (chopped or continuous), carbon, aramid and other polymeric materials.

1.10 A wide variety of chemical additives are typically added to SGPL formulations. Examples include colorants, chemical foaming agents, ultraviolet stabilizers, fire retardants, lubricants, anti-static products, heat stabilizers, and coupling agents.

1.11 Diverse types and combinations of filler systems are permitted in the manufacturing of SGPL products. Fillers that cause the product to fail the requirements of 6.13 are not permitted in the manufacturing of SGPL products.

1.12 In order for a product to be classified as SGPL, it must meet the minimum stress and modulus criteria consistent with the specific product as marked, and additionally the properties specified in Section 6 of this specification.

1.13 This specification pertains to SGPL where any reinforcement is uniformly distributed within the product. When reinforcement is not uniformly distributed, the engineering issues become substantially more complex. For this reason, such products are not covered in this document.

1.14 Products that fail at strains of less than 0.02 (2 %) when tested in flexure in accordance with 6.6 are not compatible with the underlying assumptions of Annex A1 and are beyond the scope of this standard (see Note 1).

NOTE 1—Calculation of time-dependent properties in Annex A1 is based on the assumption that the product does not fail in a brittle manner. The 2 % strain limit was selected based on the judgment of the task group members that created Annex A1.

1.15 This specification addresses issues relevant to a buyer's requirements for SGPL products and has therefore been developed in the format of a procurement specification.

1.16 Criteria for design are included as part of this specification for SGPL products.

<sup>1</sup> This specification is under the jurisdiction of ASTM Committee D20 on Plastics and is the direct responsibility of Subcommittee D20.20 on Plastic Lumber.

Current edition approved June 1, 2013. Published June 2013. Originally approved in 2012. Last previous edition approved in 2012 as D7568 – 12. DOI:10.1520/D7568-13.

1.17 Use of SGPL members in application will typically require the design of structural connections. Connection design between SGPL members falls outside the scope of this standard.

1.18 The values are stated in inch-pound units, as these are currently the most common units used by the US construction industry. Equivalent SI units are indicated in parentheses.

1.19 *This standard does not purport to address all of the safety concerns, if any, associated with its use. It is the responsibility of the user of this standard to establish appropriate safety and health practices and determine the applicability of regulatory limitations prior to use.*

NOTE 2—There is no known ISO equivalent to this Standard.

## 2. Referenced Documents

2.1 The following documents of the issue in effect on the date of product purchase form a part of this specification to the extent referenced herein:

### 2.2 ASTM Standards:<sup>2</sup>

**D883 Terminology Relating to Plastics**

**D2344/D2344M Test Method for Short-Beam Strength of Polymer Matrix Composite Materials and Their Laminates**

**D2915 Practice for Sampling and Data-Analysis for Structural Wood and Wood-Based Products**

**D6108 Test Method for Compressive Properties of Plastic Lumber and Shapes**

**D6109 Test Methods for Flexural Properties of Unreinforced and Reinforced Plastic Lumber and Related Products**

**D6112 Test Methods for Compressive and Flexural Creep and Creep-Rupture of Plastic Lumber and Shapes**

**D6341 Test Method for Determination of the Linear Coefficient of Thermal Expansion of Plastic Lumber and Plastic Lumber Shapes Between –30 and 140°F (–34.4 and 60°C)**

**D6662 Specification for Polyolefin-Based Plastic Lumber Decking Boards**

**D7032 Specification for Establishing Performance Ratings for Wood-Plastic Composite Deck Boards and Guardrail Systems (Guards or Handrails)**

**E84 Test Method for Surface Burning Characteristics of Building Materials**

### 2.3 Other Documents:

**ASCE 7 Minimum Design Loads for Buildings and Other Structures<sup>3</sup>**

## 3. Terminology

3.1 *Definitions of Terms*—For definitions of terms used in this specification associated with plastics issues refer to the terminology contained in Terminology **D883**.

### 3.2 Definitions:

3.2.1 *plastic lumber, n*—a manufactured product made primarily from plastic materials (filled or unfilled), typically used as a building material for purposes similar to those of traditional lumber, which is usually rectangular in cross-section. (Terminology **D883**)

3.2.1.1 *Discussion*—Plastic lumber is typically supplied in sizes similar to those of traditional lumber board, timber and dimension lumber; however the tolerances for plastic lumber and for traditional lumber are not necessarily the same. (Terminology **D883**)

3.2.2 *resin, n*—a solid or pseudo solid organic material often of high molecular weight, which exhibits a tendency to flow when subjected to stress, usually has a softening or melting range, and usually fractures conchoidally (Terminology **D883**).

3.2.2.1 *Discussion*—In a broad sense, the term is used to designate any polymer that is a basic material for plastics.

### 3.3 Definitions of Terms Specific to This Standard:

3.3.1 *bulge, n*—convex distortion (away from the center of the cross-section) of the face of the product from a straight line drawn from edge to edge across the width.

3.3.2 *crook, n*—distortion of the product in which there is a deviation in a direction perpendicular to the edge from a straight line from end to end along the length.

3.3.3 *cup, n*—concave distortion (towards the center of the cross-section) of the face of the product from a straight line drawn from edge to edge across the width.

3.3.4 *edge, n*—the side of a rectangular-shaped product corresponding to the thickness.

3.3.5 *face, n*—the side of a product corresponding to the width.

3.3.6 *reinforcement, n*—a material added to the thermoplastic resin to improve its mechanical properties.

3.3.7 *self-supporting specimen, n*—a specimen that remains in place by its own structural characteristics both before and during a fire test.

3.3.8 *structural grade plastic lumber, n*—a solid, rectangular reinforced thermoplastic composite lumber product manufactured for load-bearing applications such as joists, beams, or columns in outdoor structures.

3.3.9 *test set, n*—a full complement of test specimens required for a specific assessment.

3.3.9.1 *Discussion*—As an example, a test set for flexural properties (see **6.6.3**) requires 28 test specimens.

3.3.10 *thickness, n*—the lesser dimension of the cross-sectional profile of a rectangular-shaped product.

3.3.11 *width, n*—the greater dimension of the cross-sectional profile of a rectangular-shaped product, or the dimension of the cross-sectional profile of a square product.

## 4. Ordering Information

4.1 The information contained in this specification is intended to be helpful to producers, distributors, regulatory agencies and users including designers, architects, and engineers. The information will also promote understanding between purchasers and sellers. The purchaser shall state whether

<sup>2</sup> For referenced ASTM standards, visit the ASTM website, [www.astm.org](http://www.astm.org), or contact ASTM Customer Service at [service@astm.org](mailto:service@astm.org). For *Annual Book of ASTM Standards* volume information, refer to the standard's Document Summary page on the ASTM website.

<sup>3</sup> Available from American Society of Civil Engineers (ASCE), 1801 Alexander Bell Dr., Reston, VA 20191, <http://www.asce.org>.

this specification is to be used, select the preferred options permitted herein, and include the allowable design information in the invitation to bid and purchase order from the following:

- 4.1.1 Title, number and date of this specification,
- 4.1.2 Minimum allowable bending stress and apparent bending stiffness,
- 4.1.3 Percent recycled content (if requested),
- 4.1.4 Flame spread index,
- 4.1.5 Color,
- 4.1.6 Quantity in lineal feet,
- 4.1.7 Cut length,
- 4.1.8 Cross-sectional dimensions,
- 4.1.9 Packing requirements,
- 4.1.10 Palletization, if required,
- 4.1.11 Marking, if other than specified.

**5. Dimensions and Permissible Variations**

5.1 It is permissible to produce SGPL either in sizes that are similar to the standard dimensions of the wood industry, or to other dimensions designated by manufacturers or buyers. This specification does not limit the dimensional range of production.

5.2 Use of a licensed Professional Engineer is recommended for designing and selecting SGPL products in accordance with this specification.

5.3 *Thickness*—Unless otherwise specified in 4.1.8, product thickness tolerance shall be:

For members less than 2 in. in nominal thickness the tolerance on thickness shall be  $+3/16$  /  $-1/16$ .

Nominal (in.)	Actual (in.)	Tolerance (in.)
2	1½	+3/16 / -1/16
3	2½	+3/16 / -1/16
4	3½	+3/16 / -3/32
5	4½	+3/16 / -3/32
6	5½	+ 3/16 / -1/8

For members greater than 6 in. in nominal thickness the tolerance on thickness shall be  $+3/16$  /  $-1/8$  inch.

5.4 *Width*—Unless otherwise specified in 4.1.8, product width shall be:

For members less than 3 in. in nominal width the tolerance on width shall be  $+3/16$  /  $-1/16$  inch.

Nominal (in.)	Actual (in.)	Tolerance(in.)
3	2½	+3/16 / -1/16
4	3½	+3/16 / -3/32
6	5½	+3/16 / -3/32
8	7¼	+3/16 / -1/8
10	9¼	+ 3/16 / -1/8
12	11¼	+1/4 / -5/32

For members greater than 12 in. in nominal width the tolerance on width shall be  $+1/4$  /  $-5/32$  inch.

5.5 *Length*—Unless otherwise specified in 4.1.7, products up to 20 ft shall have tolerances of  $\pm 1/2$  inch. Over 20 feet the tolerances shall be  $\pm 1/2$ -in. per 20-ft of length or fraction thereof. Measurement of lengths shall be made at  $23 \pm 2^\circ\text{C}$  ( $73.4 \pm 4^\circ\text{F}$ ) and relative humidity of  $50 \pm 5\%$ .

5.6 *Flatness Tolerance*—Products shall be flat with a maximum cup or bulge in the face limited to the tolerances in Table 1 and Table 2. Linear interpolation of the values is acceptable for dimensions other than listed.

**TABLE 1 Cup or Bulge Tolerances Relative to Nominal Width (2x)**

Face Width, in.	≤4 in.	6 in.	8 in.	10 in.	12 in.
Tolerance (±)	1/16 in.	3/32 in.	1/8 in.	3/16 in.	1/4 in.

**TABLE 2 Cup or Bulge Tolerances Relative to Nominal Size (square)**

Size, in.	≤4 in.	6 in.	8 in.	10 in.	>12 in.
Tolerance (±)	3/32 in.	1/8 in.	3/16 in.	1/4 in.	1/4 in.

5.7 *Squareness*—Unless a specially shaped member is specified, the cross-section of all structural-grade plastic lumber products shall be perpendicular (that is, 90 degree angle from face to edge of a square or rectangular shape and suited for the intended purpose).

5.8 *Crook*—Crook shall conform to the tolerances in Table 3. Linear interpolation of the values is acceptable for dimensions other than listed.

**6. Performance Requirements**

6.1 *Load Combinations*: Plastic members subject to multiple load types shall be checked for all applicable load combinations. Load factors and load reductions shall be determined in accordance with the applicable code or ASCE 7. All applicable load combinations shall be evaluated to determine the critical load combination to be used in design.

NOTE 3—Application of load duration factors to load combinations in which each load has a different associated duration is a complex process and varies depending on whether the design engineer is using allowable stress design (ASD) or load and resistance factor design (LRFD) methodology. A conservative design approach applies the load duration factor equal to the longest duration in the applicable load combination. More refined approaches for specific applications can be found in the technical literature.

6.2 *Design Properties*:

6.2.1 All members shall be designed such that for all load combinations:

$$f_a \leq F_n' \times C_D \tag{1}$$

where:

- $f_a$  = total applied stress in each combination (psi)
- $F_n'$  = allowable stress as calculated in 6.6.3.2, 6.7.2, 6.8.2.1, 6.8.3.1, or 6.9.3.2 (psi)
- $C_D$  = Load Duration Factor for the material and considered load duration. Derivation of  $C_D$  is explained in Annex A2.

6.3 *Interpolation of Properties*:

6.3.1 Interpolation of mechanical properties of a SGPL product from test data from the same product at other width dimensions is permitted if the test results verify a logical progression of properties and the following conditions are met:

6.3.1.1 All specimens have the same thickness and material composition.

**TABLE 3 Crook Tolerances Relative to Nominal Length and Width**

Length in Feet	≤4 in.	6 in.	8 in.	10 in.	12 in.
	Width	Width	Width	Width	Width
4-6	3/8 in.	1/4 in.	3/16 in.	3/16 in.	3/16 in.
8	1/2 in.	1/2 in.	3/8 in.	3/8 in.	3/8 in.
10	3/4 in.	5/8 in.	1/2 in.	1/2 in.	1/2 in.
12	1 in.	7/8 in.	13/16 in.	13/16 in.	13/16 in.
14	1-1/4 in.	1-1/8 in.	1 in.	1 in.	1 in.
16	1-1/2 in.	1-3/8 in.	1-1/8 in.	1-1/8 in.	1-1/8 in.

6.3.1.2 Three or more test sets are performed on specimens with varying width.

6.3.1.3 At least one test set is performed on specimens with a width greater than that of the product whose properties are being interpolated.

6.3.1.4 At least one test set is performed on specimens with a width less than that of the product whose properties are being interpolated.

#### 6.4 Creep Rupture:

6.4.1 Creep Rupture tests shall be performed for the intended use (that is, flexural test for a flexural member, compression test for a compression member) in accordance with the procedures outlined in Test Methods **D6112**.

6.4.2  $F_{cr}$  shall be the stress required to cause creep rupture in ten years determined from the creep rupture curve calculated in Test Methods **D6112**.

6.4.3  $E_{cr}$  shall be the effective ten-year modulus determined from the creep rupture curve calculated in Test Methods **D6112**.

6.4.4 The combined effect of time (that is, creep rupture) and temperature determined by Test Methods **D6112** shall be compared against the product of  $C_{TF}$  and  $\beta$ . The more conservative result shall form the basis of design.

#### 6.5 Serviceability:

6.5.1 Deflection shall be calculated using the apparent modulus of elasticity determined in **6.6.3.3**. Calculated deflection shall not exceed applicable code or project specific deflection limits.

6.5.2 The maximum ten-year strain in any member shall not exceed 0.03 (3 %).

NOTE 4—It is possible that some applicable codes or project specific requirements will require deflection limits that result in a maximum strain of less than 0.03.

#### 6.6 Flexural Members:

6.6.1 The test procedure shall be in accordance with Test Methods **D6109** with the following modifications:

6.6.1.1 The specimens for flexural members shall be tested in the joist configuration (Method B in Test Methods **D6109**) unless it is shown that the minimum properties in the plank configuration also hold for the joists and that there is no size effect for the product.

6.6.2 *SGPL Requirements*—SGPL shall meet or exceed the following criteria:

6.6.2.1 The mean value of the secant flexural modulus minus one standard deviation of the value at 1 % outer fiber strain shall equal or exceed 200,000 psi at  $23 \pm 2^\circ\text{C}$  ( $73.4 \pm 4^\circ\text{F}$ ) and  $50 \pm 10\%$  RH.

6.6.2.2 The mean, minus two standard deviations, value of the flexural stress  $F_{bt}$  at 3 % outer fiber strain shall equal or exceed 2,000 psi at  $23 \pm 2^\circ\text{C}$  ( $73.4 \pm 4^\circ\text{F}$ ). If any SGPL product fails prior to reaching 3 % strain, then the mean, minus two standard deviations, of the flexural stress at failure for that product shall equal or exceed 2,000 psi.

NOTE 5—The typical mode of failure for SGPL members results from flexure by excessive strain rather than by rupture. Thus, the requirement in the standard flexural test is to define the failure stress as the stress at 3 % strain, if rupture has not occurred before that point.

#### 6.6.3 Allowable Flexural Properties:

6.6.3.1 *Specimens Tested*—A minimum of 28 specimens shall be tested at  $23 \pm 2^\circ\text{C}$  ( $73.4 \pm 4^\circ\text{F}$ ). Specimens selected for testing shall be representative of typical production and shall be selected to include sources of potential variability.

6.6.3.2 *Allowable Flexural Stress*—The allowable flexural stress,  $F_b'$ , of a product is given as follows (see temperature tolerances in **6.6.3.1**):

$$F_b' = (F_b/FS) * C_{TF} * C_L \quad (2)$$

where:

$F_b$  = the base flexural stress value at  $23^\circ\text{C}$  ( $73.4^\circ\text{F}$ ) for normal duration loading (10 yr. duration), (psi), which is defined as follows:

$$F_b = F_{bt} * \beta \leq F_{cr} \quad (3)$$

where:

$F_{bt}$  = the non-parametric 5 % lower tolerance limit at 75 % confidence of the flexural stress at 3 % outer fiber strain (or failure if 3 % strain cannot be reached) determined from flexure tests conducted in accordance with Section **6.6.1** (psi). Statistical calculations shall be in accordance with Practice **D2915**.  $F_{bt}$  shall meet the requirements of **6.6.2**

$F_{cr}$  = ultimate creep rupture stress for flexure calculated in accordance with **6.4**, (psi)

$\beta$  = Stress-time factor to convert the test value,  $F_{bt}$ , to a ten-year normal duration value. This value shall be determined in accordance with **Annex A1**.

$FS$  = factor of safety = 2.5,

$C_{TF}$  = temperature factor for flexure determined in accordance with **Annex A3**

$C_L$  = beam stability factor determined using principles of engineering mechanics.

NOTE 6—Discussion of beam stability is provided in **X1.2**.

6.6.3.3 *Apparent Modulus of Elasticity and Adjustment for Creep*—The apparent modulus of elasticity,  $E'$ , shall be determined as follows:

$$E' = E * C_{TE} / \alpha \leq E_{cr} \quad (4)$$

where:

$E$  = modulus as determined from Test Methods **D6109**, except that it represents the chord modulus values between 0.1  $F_{bt}$  and 0.4  $F_{bt}$ , (psi)

$E_{cr}$  = the effective ten-year stiffness determined in accordance with **6.4**, (psi)

$C_{TE}$  = temperature factor for modulus determined in accordance with **Annex A3**

$\alpha$  = creep adjustment factor determined in accordance with **Annex A1**.

NOTE 7—An example problem for the case of uniform loading on a single span joist is described in **Appendix X4**.

6.6.3.4 For uniform loading at an average ambient temperature of  $90^\circ\text{F}$  the maximum total deflection of the structural-grade plastic lumber product including the effect of creep shall not exceed  $L/180$  or as otherwise specified by the applicable code.

#### 6.7 Shear Properties:



6.7.1 *Test Procedure*—Test Method **D2344/D2344M** incorporating the following criteria and modifications:

6.7.1.1 *Specimen Size for Testing*—Specimens for test shall not be machined to reduce the cross-sectional thickness—only full-size cross sections shall be used. Also, in accordance with subsection 5.3 of Test Method **D2344/D2344M**, span length-to-specimen thickness ratio of 4 shall be used for the specimen size.

6.7.1.2 *Specimens Tested*—A minimum of 28 specimens shall be tested. Specimens selected for testing shall be representative of typical production and shall be selected to include sources of potential variability.

6.7.1.3 An extension indicator shall be affixed to the specimen to record the displacement (strain) of the specimen below the upper loading nose as a function of applied stress. The recorded stress-strain data shall also be reported.

6.7.1.4 Use the short beam stress,  $F_{sbs}$ , as calculated in Equation (1) of Test Method **D2344/D2344M** as the shear stress value  $F_v$  in Equation (9) below.

6.7.2 *Allowable Shear Stress*—The allowable shear stress of a product is given as follows:

$$F_v' = (F_v/FS) * C_{TF} \quad (5)$$

where:

$F_v$  = the base shear stress value at 23°C (73.4°F) for normal duration loading (10-year duration), (psi) defined below,

$FS$  = factor of safety = 2.5,

$C_{TF}$  = temperature factor for flexure, determined in accordance with Annex A3

$F_v$ , the base shear stress value for the product is determined as follows:

$$F_v = F_{vt} * \beta \leq F_{cr} \quad (6)$$

where:

$F_{vt}$  = the non-parametric 5 % lower tolerance limit at 75 % confidence of the shear stress at 3 % fiber strain (or failure if 3 % strain cannot be reached) determined from shear tests conducted in accordance with 6.7.1 (psi). Statistical calculations shall be in accordance with Practice **D2915**.

$F_{cr}$  = ultimate creep rupture stress for shear calculated in accordance with 6.4, (psi)

$\beta$  = stress-time factor to convert the test value,  $F_v$ , to a ten year normal duration value. This value shall be determined in accordance with Annex A1.

6.8 *Bearing*:

6.8.1 Tests shall be performed in accordance with Test Method **D6108** with the following modifications:

6.8.1.1 *Specimens Tested*—A minimum of 28 specimens shall be tested at  $23 \pm 2^\circ\text{C}$  ( $73.4 \pm 4^\circ\text{F}$ ). Specimens selected for testing shall be representative of typical production and shall be selected to include sources of potential variability.

6.8.1.2 *Bearing Perpendicular to the Direction of Extrusion*:

(1) *Test Method D6108, Subsection 6.2*: The standard test specimen shall take the form of the actual manufactured product cross-section with a length equal to half its width.

(2) *Test Method D6108, Subsection 10.2*: Place the test specimen between the surfaces of the compression platens, taking care to align the center line of the surface perpendicular to the extrusion with the center line of the platens to ensure that the ends of the specimen are parallel with the surface of the platens. The proper positioning of a member with dimensions  $b \times d$  is shown in Fig. 1. Adjust the crosshead of the testing machine until it just contacts the top of the compression platen.

6.8.1.3 *Bearing Parallel to the Direction of Extrusion*:

(1) *Test Method D6108, Subsection 6.2*: The standard test specimen shall take the form of the actual manufactured product cross-section with a width equal to twice its length.

(2) *Test Method D6108, Subsection 10.2*: Place the test specimen between the surfaces of the compression platens, taking care to align the center line of the surface parallel to the extrusion with the center line of the platens to ensure that the ends of the specimen are parallel with the surface of the platens. The proper positioning of a member with dimensions  $b \times d$  is shown in Fig. 2. Adjust the crosshead of the testing machine until it just contacts the top of the compression platen.

6.8.2 *Bearing Perpendicular to Extrusion*:

6.8.2.1 *Allowable Bearing Stress*—The allowable bearing stress,  $F_{C\perp}'$ , of a product loaded in compression perpendicular to the extrusion direction is given as follows (see temperature tolerances in 6.8.1.1):

$$F_{C\perp}' = (F_{C\perp}/FS) * C_{TC} \quad (7)$$

$F_{C\perp}$  = the base bearing stress value at 23°C (73.4°F), (psi) defined below,

$FS$  = factor of safety = 2.5,

$C_{TC}$  = temperature factor for compression, determined in accordance with Annex A3,

$F_{C\perp}$ , the base bearing stress value for the product is determined as follows:

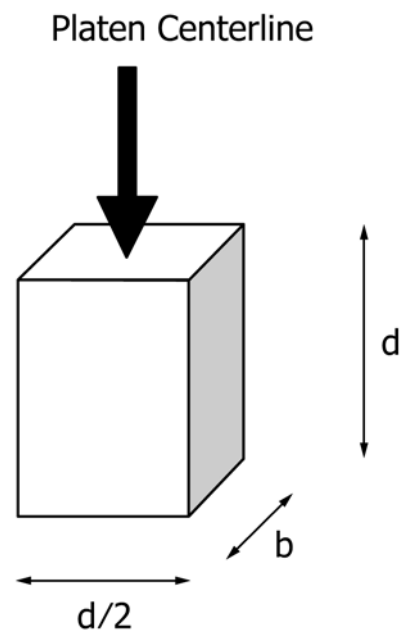

FIG. 1 Bearing Perpendicular to the Direction of Extrusion Platen Centerline

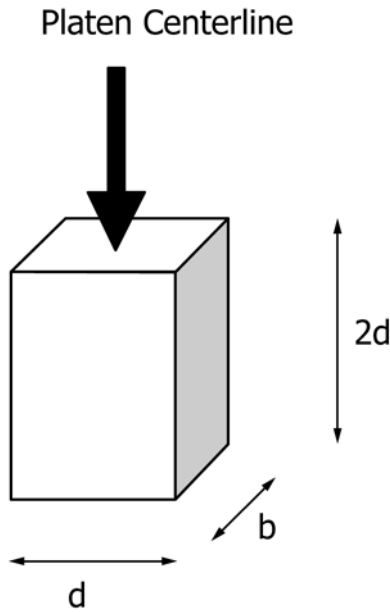

FIG. 2 Bearing Parallel to the Direction of Extrusion Platen Centerline

$$F_{C\perp} = F_{C\perp, 5\%} \beta \leq F_{cr} \quad (8)$$

where:

$F_{C\perp, 5\%}$  = the non-parametric 5 % lower tolerance limit at 75 % confidence of the bearing stress perpendicular to the extrusion direction at 3 % fiber strain (or failure if 3 % strain cannot be reached) determined from bearing tests conducted in accordance with 6.8.1 (psi). Statistical calculations shall be in accordance with Practice D2915.

$F_{cr}$  = the ultimate creep rupture stress for bearing perpendicular to the direction of extrusion calculated in accordance with 6.4, (psi)

$\beta$  = stress-time factor to convert the test value,  $F_{C\perp, 5\%}$ , to a ten year normal duration value. This value shall be determined in accordance with Annex A1.

### 6.8.3 Bearing Parallel to Extrusion:

6.8.3.1 Allowable Bearing Stress—The allowable bearing stress,  $F_{C\parallel}$ , of a product loaded in compression parallel to the extrusion direction is given as follows:

$$F_{C\parallel} = (F_{C\parallel} / FS) * C_{TC} \quad (9)$$

where:

$F_{C\parallel}$  = the base bearing stress value at 23°C (73.4°F), (psi) defined below

FS = factor of safety = 2.5,

$C_{TC}$  = temperature factor for compression, determined in accordance with Annex A3,

$F_{C\parallel}$ , the base bearing stress value for the product is determined as follows:

$$F_{C\parallel} = F_{C\parallel, 5\%} \beta \leq F_{cr} \quad (10)$$

where:

$F_{C\parallel, 5\%}$  = the nonparametric 5 % lower tolerance limit at 75 % confidence of the bearing stress parallel to the extrusion direction at 3 % fiber strain (or failure if 3 % strain cannot be reached) determined from bearing tests conducted in accordance with 6.8.1 (psi). Statistical calculations shall be in accordance with Practice D2915.

$F_{cr}$  = ultimate creep rupture stress for compression parallel to the direction of extrusion calculated in accordance with 6.4, (psi)

$\beta$  = stress-time factor to convert the test value,  $F_{C\parallel, 5\%}$ , to a ten year normal duration value. This value shall be determined in accordance with Annex A1.

### 6.9 Compression Members:

#### 6.9.1 Test Procedure—Test Method D6108.

6.9.1.1 Specimens Tested—A minimum of 28 specimens shall be tested at 23 ± 2°C (73.4 ± 4°F). Specimens selected for testing shall be representative of typical production and shall be selected to include sources of potential variability.

6.9.2 SGPL Requirements—SGPL shall meet or exceed the following criteria:

6.9.2.1 The mean minus one standard deviation value of the secant compression modulus at 1 % strain shall equal or exceed 120,000 psi at 23 ± 2°C (73.4 ± 4°F) and 50 ± 10 % RH.

6.9.2.2 The mean, minus two standard deviations, value of the compressive stress  $F_{ct}$  at 3 % strain shall equal or exceed 1,500 psi at 23 ± 2°C (73.4 ± 4°F) and 50 ± 10 % RH. If any SGPL product fails prior to reaching 3 % strain, then the mean, minus two standard deviations, of the stress at failure for that product shall equal or exceed 1,500 psi.

NOTE 8—Often the compression modulus and stress values of SGPL are significantly lower than the flexural modulus and stress values.

#### 6.9.3 Design of Compression Members:

6.9.3.1 SGPL compression members shall meet the following slenderness ratio limitation:

$$S_r = K L_u / r < 28 \quad (11)$$

where:

$S_r$  = slenderness ratio,

$K$  = buckling length coefficient (greater than or equal to 1.0) that depends on the end constraint for the column.

$L_u$  = unbraced length of the member, (in.)

$r$  = radius of gyration (in.)

The above slenderness ratio shall be checked for both principle bending axes of the member.

NOTE 9—This slenderness ratio limitation has been used by SGPL manufacturers in the past. Due to the broad range of products covered by this standard, designers are cautioned to check all compression members for potential buckling using the properties of the product being used. Discussion of column stability is provided in Appendix X1.2. Specific discussion of column slenderness ratio is provided in X1.2.7.4

6.9.3.2 The allowable compressive stress,  $F_c'$ , of a product is given as follows:

$$F_c' = (F_c/FS) * C_{TC} * C_p \quad (12)$$

where:

$F_c$  = the base compressive stress value at 23°C (73.4°F) for normal duration loading (10 yr. duration), (psi) as defined below,

$$F_c = \beta * F_{ct} \leq F_{cr} \quad (13)$$

where:

$F_{ct}$  = the non-parametric 5 % lower tolerance limit at 75 % confidence of the compressive stress at 3 % fiber strain determined from compression tests conducted in accordance with 6.9.1 (psi). Statistical calculations shall be in accordance with Practice D2915.  $F_{bc}$  shall meet the requirements of 6.9.2.

$F_{cr}$  = ultimate creep rupture stress for compression calculated in accordance with 6.4, (psi)

$\beta$  = stress-time factor to convert the test value,  $F_{ct}$ , to a ten year normal duration value. This value shall be determined in accordance with Annex A1,

$FS$  = factor of safety = 2.5,

$C_{TC}$  = temperature factor for compression, determined in accordance with Annex A3,

$C_p$  = column stability factor determined using principles of engineering mechanics

NOTE 10—Discussion of column stability is provided in X1.2.

#### 6.10 Combined Stresses:

6.10.1 *Bending and Compression*—Plastic members subject to both axial compression and flexure shall be proportioned using principles of engineering mechanics.

NOTE 11—Discussion of combined stresses is provided in X1.2.

6.10.2 Structures expected to experience significant side sway shall not be used unless appropriate engineering procedures or tests are employed in the design of such members to ensure that all applied loads will be safely carried by the members.

#### 6.11 Dimensional Stability—Thermal Expansion:

6.11.1 The value of the coefficient of thermal expansion shall be calculated in accordance with the test procedure outlined in Test Method D6341 with the following modifications:

6.11.1.1 *Specimens Tested*—A minimum of 15 specimens shall be tested to establish an average value. Report the measured coefficient of thermal expansion in the longitudinal or the transverse direction to two significant figures for use in design calculations.

6.11.2 Thermal expansion shall be considered for the design of expansion slots or any other case where movement due to thermal effects will cause structural or serviceability concerns. Specimens selected for testing shall be representative of typical production and shall be selected to include sources of potential variability.

#### 6.12 Weatherability:

6.12.1 SGPL products that are exposed to solar radiation shall meet the requirements of subsection 6.3.2 of Specification D6662.

NOTE 12—The testing requirements of subsection 6.3 of Specification

D6662 can only identify products with the potential to deteriorate in less than two years under outdoor conditions. However, the results from testing of plastic lumber decking boards after eleven years of outdoor exposure have shown that the boards had discolored and faded, but that both strength and stiffness were basically unchanged. Similar results are expected with SGPL. Further details of this testing and results are given in Appendix X3 in Specification D6662

#### 6.13 Hygrothermal Cycling:

6.13.1 *Test Procedure*—Specimens shall also be prepared as described in Test Methods D6109. Each specimen shall then be weighed to the nearest 0.00022 lb (0.1 g). Specimens shall then be totally submerged underwater (using weights to hold down, if necessary) for a period of 24 hours. After removal from water, each specimen shall then be dried with a dry cloth on the outside surfaces and weighed again within 20 minutes. The specimens shall then be frozen to  $-20 (\pm 5)^\circ\text{F}$  ( $-29 (\pm 2)^\circ\text{C}$ ) for 24 hours, then returned to room temperature. The above process completes one hygrothermal cycle.

6.13.2 The procedure in 6.13.1 shall be repeated two more times, for a total of three cycles of water submersion, moisture absorption equilibrium, and freezing. After completion of these steps, the specimens shall be returned to room temperature and tested as described in Test Methods D6109.

6.13.3 *Specimens Tested*—A minimum of 15 specimens shall be prepared in accordance with Test Methods D6109 and tested. Specimens selected for testing shall be representative of typical production and shall be selected to include sources of potential variability.

6.13.4 *Criteria*—Any obvious physical changes that occur as a result of the hygrothermal cycling shall be noted. The flexural modulus and the greater of the stress level at 3% strain or the stress at fracture as defined in Test Methods D6109 shall retain 90 % of the mean value when tested without hygrothermal cycling in accordance with 6.6.3.2.

#### 6.14 Flame Spread Index:

6.14.1 The flame spread index of SGPL products shall be determined by testing in accordance with Test Method E84.

6.14.2 A minimum of five test specimens shall be tested.

6.14.3 The test specimens shall either be self-supporting by their own structural characteristics or held in place by added supports along the test specimen surface. The test specimen shall remain in place throughout the test duration, without such severe sagging that it interferes with the effect of the gas flame on the test specimen. Test results are invalid if the bulk of the test specimen melts or drops to the furnace floor.

6.14.4 Appendix X1 of Test Method E84 provides guidance on mounting methods.

6.14.5 Products shall have a flame spread index no greater than 200 when tested in accordance with Test Method E84.

NOTE 13—For combustible construction, codes often require fire performance at least equivalent to that of wood. A maximum flame spread index of 200 when tested in accordance with Test Method E84 is considered to be equivalent to that of wood. For outdoor applications, there is no requirement specified for smoke developed index.

NOTE 14—Fire retardants are available to increase the resistance to ignitability and flame spread of SGPL and shall be incorporated as needed.

## 7. Specimen Conditioning

7.1 *Conditioning of Specimens for Tests*—Unless specifically stated otherwise, all specimens shall be conditioned and tested in accordance with the appropriate test method.

## 8. Workmanship

8.1 The structural-grade plastic lumber products furnished in accordance with this specification shall be an acceptable match to approved samples in pattern, color, and surface appearance. The products shall be free of defects that adversely affect performance or appearance. Such defects include blemishes, spots, indentations, cracks, blisters, and breaks in corners or edges.

## 9. Product Technical Data Sheet

9.1 The manufacturer shall provide the following information for each product:

- 9.1.1 Flexural properties as determined in 6.6.
- 9.1.2 Shear properties as determined in 6.7.
- 9.1.3 Bearing properties as determined in 6.8.
- 9.1.4 Compression properties as determined in 6.9.
- 9.1.5 Temperature adjustment factors for flexural stress and modulus in accordance with Annex A3.

9.1.6 Temperature adjustment factor for compression in accordance with Annex A3.

9.1.7 Stress-time adjustment factor,  $\beta$ , for flexure in accordance with Annex A1.

9.1.8 Creep adjustment factor,  $\alpha$ , for flexure in accordance with Annex A1.

9.1.9 Ten-year modulus in accordance with 6.4.3.

9.1.10 Load duration factors for range of time periods in accordance with Annex A2.

9.1.11 Creep rupture value for stress,  $F_{cr}$  in accordance with 6.4.2.

## 10. Quality Assurance

10.1 A quality assurance program shall be employed to verify compliance with specific portions of this specification.

## 11. Packaging and Packing

11.1 The products shall be packaged in accordance with normal commercial practice and packed to assure acceptance by common carrier and to provide protection against damage during normal shipping, handling, and storage.

## 12. Keywords

12.1 plastic lumber; polyethylene; recycled plastics; reinforced; structural grade composite lumber

iTech Standards  
(<https://standards.iteh.ai>)  
ANNEXES  
(Mandatory Information)  
Document Preview

### A1. DERIVATION OF ALPHA AND BETA FACTORS AND CREEP CURVES

A1.1 The procedures in this annex were developed based on testing of a specific formulation of structural grade plastic lumber. They provide one method for determination of adjustment factors for time-dependent properties. These procedures have been used successfully to support designs of several demonstration bridges and railroad tie applications. However, during development of this standard, committee members expressed the need to expand the experimental backup data to include a wider range of formulations. This process is currently underway.

A1.2 The following method shall be used to calculate  $\alpha$ ,  $\beta$ , and development of creep curves based on short-term experimental data. This procedure is based on a Rutgers University thesis titled “Time Dependence of the Mechanical Properties of an Immiscible Polymer Blend” by Jennifer Lynch dated October 2002. For use in design, these values shall be compared against the creep-rupture factors determined in accordance with Test Methods D6112 and the more conservative shall apply.

A1.2.1 Perform five constant strain rate tests at  $\dot{\epsilon} = 3 \text{ \%}/\text{min}$  in accordance Test Methods D6109. Continue the test until 5 % strain or until rupture. Record all data at the same time interval for all tests. Determine the average values of load, deflection, stress, strain, and strain energy density (SED =  $\sigma\epsilon$ ) for each

time interval recorded. If the coefficient of variation at any time interval is greater than 8 % increase the number of specimens in accordance with subsection 3.4.2 of Practice D2915 until the coefficient of variation is less than 8 %. Fit fifth order polynomial regression curves for stress versus time and SED versus strain.

$$\sigma_3 \%(t) = A_5 t^5 + A_4 t^4 + A_3 t^3 + A_2 t^2 + A_1 t \quad (\text{A1.1})$$

$$SED_3 \%( \epsilon ) = B_5 \epsilon^5 + B_4 \epsilon^4 + B_3 \epsilon^3 + B_2 \epsilon^2 + B_1 \epsilon \quad (\text{A1.2})$$

where:

$A_x$  and  $B_x$  = regression constants for each curve.

A1.2.2 Repeat the procedure outlined in A1.2.1 for a strain rate of  $\dot{\epsilon}' = 0.03 \text{ \%}/\text{min}$ . Provide all test data and regression curves required by A1.2.1.

*Discussion*—It is permitted to use strain rates other than those recommended in A1.2.1 and A1.2.2 provided that the strain rate of A1.2.1 is approximately 100 times the strain rate of A1.2.2. For the remainder of this procedure  $\epsilon_3 \text{ \%}$  and  $\epsilon_{0.03\%}$  are left as variables to allow the use of alternate strain rates.

A1.2.3 Procedure for determining the rate relation exponent function  $m$  ( $\sigma_{\epsilon_{0.03\%}}$ ):

A1.2.3.1 Select 30 SED values such that the interval between values is equal and the largest value is equal to the



largest SED from the 0.03 %/min strain rate test. Each SED value shall be calculated using the following equation:

$$SED_i = (SED_{max,0.03\%}) * i/30 \quad (A1.3)$$

where:

$i = 1$  through 30.

A1.2.3.2 For both the 0.03 %/min test and the 3 %/min test determine the strain for each SED value calculated in A1.2.3.1 using Eq A1.3. Calculate stress ( $\sigma = SED/\epsilon$ ) and time ( $t = \epsilon/\dot{\epsilon}$ ) for each SED value.

A1.2.3.3 For each SED value, determine a value of  $m$ , as given by the following equation:

$$m = \frac{\log\left(\frac{\epsilon_{0.035\%}}{\epsilon_{3\%}}\right)}{\log\left(\frac{\epsilon_{3\%}}{\epsilon_{0.035\%}}\right)} \quad (A1.4)$$

A1.2.3.4 From the 30 calculated  $m$  values, fit a fifth order polynomial regression curve:

$$m(\sigma\epsilon_{0.03\%}) = C_{5\epsilon_{0.03\%}} \epsilon_{0.03\%}^5 + C_{4\epsilon_{0.03\%}} \epsilon_{0.03\%}^4 + C_{3\epsilon_{0.03\%}} \epsilon_{0.03\%}^3 + C_{2\epsilon_{0.03\%}} \epsilon_{0.03\%}^2 + C_{1\epsilon_{0.03\%}} \epsilon_{0.03\%} \quad (A1.5)$$

A1.2.4 Procedure for determining ten-year failure stress and for predicting creep - The steps outlined in A1.2.4.2 through A1.2.4.4 for determining stress, together with the steps outlined in A1.2.4.5 through A1.2.4.9 for predicting creep are iterative processes. These steps shall be performed using mathematical computer software capable of performing numerical iterations.

A1.2.4.1 Procedure for determining ten-year failure stress

A1.2.4.2 For each of the 30 SED values calculated in A1.2.3.1 calculate the predicted stress at ten years with the equation:

$$\sigma_{10} = \sigma_{0.03\%/min} * (\epsilon_{10}/\epsilon_{0.03\%})^{m(\sigma\epsilon)} \quad (A1.6)$$

where:

$\sigma_{0.03\%/min}$  = stress from 0.03 %/min test for a particular SED value.

$\epsilon_{10}$  =  $\epsilon_f/(5,256,000 \text{ min})$

$m(\sigma\epsilon)$  =  $m$  as a function of SED calculated in A1.2.3.4, and

$\epsilon_f$  = the lesser of 0.03 or the strain corresponding to the creep rupture strain,  $F_{cr}$  calculated in 6.4.

A1.2.4.3 For the 30 predicted stress values fit a fifth order polynomial regression curve for stress versus strain:

$$\sigma_{10}(\epsilon) = D_5 \epsilon^5 + D_4 \epsilon^4 + D_3 \epsilon^3 + D_2 \epsilon^2 + D_1 \epsilon \quad (A1.7)$$

where:

$D_x$  = regression constants, and

$\epsilon$  =  $SED/\sigma_{10}$

A1.2.4.4 Calculate the failure stress at ten years by substituting  $\epsilon_f$  into Eq A1.7:

$$\sigma_{f,10} = \sigma_{10}(\epsilon_f) \quad (A1.8)$$

where:

$\epsilon_f$  = the initial failure strain estimate,

$\epsilon_{fi}$  = defined below for the first iteration, and

$\epsilon_{f,c}$  = defined in A1.2.4.9 for all subsequent iterations.

$$\epsilon_{fi} = (\epsilon_f/2) * (1 + n_c) \quad (A1.9)$$

where:

$\epsilon_f$  = the lesser of 0.03 or the strain corresponding to the creep rupture strain,  $F_{cr}$ , calculated in 6.4,

$n_c$  = an initial estimate of the creep exponent = 0.05

A1.2.4.5 Procedure for predicting creep:

A1.2.4.6 Equate the average stress of the 3%/min test with  $\sigma_{f,10}$  calculated in A1.2.4.4 and solve for  $t_{r1}$  as follows:

$$\sigma_{3\%}(t_{r1})_{ave} = \frac{\int_0^{t_{r1}} \sigma_{3\%}(t) dt}{\int_0^{t_{r1}} dt} = \sigma_{f,10} \quad (A1.10)$$

where:

$\sigma_{3\%}(t)$  is as calculated in A1.2.1.

A1.2.4.7 Equate the average stress of the 0.03%/min test with  $\sigma_{f,10}$  calculated in A1.2.4.4 and solve for  $t_{r2}$  as follows:

$$\sigma_{0.03\%}(t_{r2})_{ave} = \frac{\int_0^{t_{r2}} \sigma_{0.03\%}(t) dt}{\int_0^{t_{r2}} dt} = \sigma_{f,10} \quad (A1.11)$$

where:

$\sigma_{0.03\%}(t)$  is as calculated in A1.2.2.

A1.2.4.8 Solve for the creep exponent  $n_c$  as follows:

$$n_c = \frac{\log\left(\frac{\epsilon_{0.03\%}}{\epsilon_{3\%}}\right)}{\log\left(\frac{t_{r1}}{t_{r2}}\right)} \quad (A1.12)$$

where:

$\epsilon_{3\%} = \epsilon_{3\%} * t_{r1}$

$\epsilon_{0.03\%} = \epsilon_{0.03\%} * t_{r2}$

A1.2.4.9 Recalculate  $\gamma_f$  to incorporate creep:

$$\epsilon_{f,c} = (\epsilon_f/2) * (1 + n_c) \quad (A1.13)$$

A1.2.4.10 Repeat A1.2.4.2 through A1.2.4.4 and A1.2.4.5 through A1.2.4.9 using  $\epsilon_{f,c}$  for  $\epsilon_f$  until there is less than 1 % variation in  $\epsilon_{f,10}$  between iterations.

A1.2.5 Perform five creep tests in accordance with Test Methods D6112, at a constant stress equal to the final iterated value of  $\sigma_{f,10}$  calculated above. Record all data at the same time interval for all creep tests. If the coefficient of variation at any time interval is greater than 8 %, increase the number of specimens in accordance subsection 3.4.2 of Practice D2915 until the coefficient of variation is less than 8 %. Plot average strain versus time and perform a power regression to determine  $n_c$ :

$$\epsilon(t) = Kt^{n_c} \quad (A1.14)$$

where:

$n_{c,test}$  shall be within 5 % of  $n_{c,predicted}$  calculated in A1.2.4.8. If the difference is greater than 5 %, recalculate  $\epsilon_{f,c}$  in A1.2.4.9 using  $n_{c,test}$  and  $\sigma_{f,10}$  in A1.2.4 with the recalculated  $\epsilon_{f,c}$ . Repeat the creep test at a constant stress equal to the recalculated  $\sigma_{f,10}$ . This shall be repeated until  $n_{c,test}$  is within 5 % of  $n_{c,predicted}$ .

A1.2.6 Calculate  $\beta$ :

$$\beta = \sigma_{f,10}/F_{bt} \quad (\text{A1.15})$$

$$E_{10} = \sigma_{f,10}/\varepsilon_{f,c} \quad (\text{A1.17})$$

where:

$F_{bt}$  = experimental flexural stress as described in 6.6.3.2, (psi)

$\sigma_{f,10}$  = the failure stress determined after sufficient iterations performed in accordance with A1.2.5.

A1.2.7 Calculate  $\alpha$ :

$$\alpha = E/E_{10} \quad (\text{A1.16})$$

where:

$E$  = the modulus of elasticity as described in 6.6.3.3 (psi)

$E_{10}$  = the failure modulus calculated as follows:

where:

$\sigma_{f,10}$  = the failure stress determined after sufficient iterations performed in accordance with A1.2.5

$\varepsilon_{f,c}$  = the final iterated ten-year failure strain as determined in A1.2.5.

NOTE A1.1—Commercial software is available for the conversion of laboratory data to the  $\alpha$  and  $\beta$  factors.

A1.2.8 In addition to calculation of  $\alpha$  and  $\beta$ , these procedures shall be used to generate creep curves (strain versus time) to assist design engineers to determine expected deformations for various design conditions.

## A2. DETERMINATION OF LOAD DURATION FACTOR $C_D$

A2.1 The following procedure shall be used to determine the load duration factor  $C_D$ . This procedure is only valid for load durations greater than or equal to three times the duration (from start to failure or 3 % strain) of the slow test described in A1.1. This procedure does not apply when creep does not have a significant impact on the failure of the member, which is the case in rapid loading. For durations less than 3 times the duration of the slow test, the value of  $C_D$  corresponding to the load duration of three times the slow test duration shall be used.

NOTE A2.1—The following procedure is an extension of the procedure presented in Annex A1. Completion of the Annex A1 procedure is required to determine  $C_D$  using the procedure presented below.

A2.1.1 Determine the duration of loading, recommended durations for typical load types are presented in Table X5.1.

A2.1.2 Determine the strain rate for the duration of loading:

$$\varepsilon_t = \varepsilon_{f,c}/t \quad (\text{A2.1})$$

where:

$\varepsilon_{f,c}$  = final iterated ten-year failure strain determined in A1.2.5,

$t$  = duration of loading.

A2.1.3 Procedure for determining t-year failure stress:

A2.1.3.1 For each of the 30 SED values calculated in A1.2.3.1 calculate the predicted stress at t years with the equation:

$$\sigma_t = \sigma_{0.03\%/min} * (\varepsilon_t/\varepsilon_{0.03\%})^{m(\sigma\varepsilon)} \quad (\text{A2.2})$$

where:

$\sigma_{0.03\%/min}$  = stress from 0.03%/min test for a particular SED value,

$\varepsilon_t$  =  $\varepsilon_{f,c}/(t \text{ min})$ ,

$m(\sigma\varepsilon)$  = m as a function of SED calculated in A1.2.3.4, and

$\varepsilon_f$  = final iterated ten-year failure strain determined in A1.2.4.9

A2.1.3.2 For the 30 predicted stress values, fit a fifth order polynomial regression curve for stress versus strain:

$$\sigma_t(\gamma) = D_5 \varepsilon^5 + D_4 \varepsilon^4 + D_3 \varepsilon^3 + D_2 \varepsilon^2 + D_1 \varepsilon \quad (\text{A2.3})$$

where:

$D_x$  = regression constants, and

$\varepsilon$  = SED/ $\sigma_t$

A2.1.3.3 Calculate the failure stress at t years by substituting  $\varepsilon_{f,c}$  into Eq A2.3:

$$\sigma_{f,t} = \sigma_t(\varepsilon_{f,c}) \quad (\text{A2.4})$$

where:

$\varepsilon_{f,c}$  is as defined in A2.1.3.1.

A2.1.4 Determine  $C_D$  for the load duration t:

$$C_D = \sigma_{f,t}/\sigma_{f,10} \quad (\text{A2.5})$$

where:

$\sigma_{f,10}$  is the final iterated value determined in A1.2.7.