



Designation: **D5456 – 12 D5456 – 13**

Standard Specification for Evaluation of Structural Composite Lumber Products¹

This standard is issued under the fixed designation D5456; the number immediately following the designation indicates the year of original adoption or, in the case of revision, the year of last revision. A number in parentheses indicates the year of last reapproval. A superscript epsilon (ϵ) indicates an editorial change since the last revision or reapproval.

INTRODUCTION

Structural composite lumber is intended for use as an engineering material for a variety of end-use applications. The composition of the lumber varies by wood species, adhesive composition, wood element size, shape, and arrangement. To provide the intended performance, composite lumber products require: (1) an evaluation of the mechanical and physical properties and their response to end-use environments, and (2) establishment of and conformance to standard performance specifications for quality.

Procedures contained in this specification are also to be used for establishing the design properties and for checking the effectiveness of property assignment and quality assurance procedures.

The quality assurance sections in this specification are intended to serve as a basis for designing quality-control programs specific to each product. The objective is to ensure that design values established in the qualification process are maintained.

This specification is arranged as follows:

	Section
Qualification	6
Determination of Allowable Design Stresses	7
Independent Inspection	8
Quality Assurance	10

1. Scope

1.1 This specification recognizes the complexity of structural glued products. Consequently, this specification covers both specific procedures and statements of intent that sampling and analysis must relate to the specific product.

1.2 This specification was developed in the light of currently manufactured products as defined in 3.2. Materials that do not conform to the definitions are beyond the scope of this specification. A brief discussion is found in Appendix X1.

1.3 Details of manufacturing procedures are beyond the scope of this specification.

NOTE 1—There is some potential for manufacturing variables to affect the properties of members that are loaded for sustained periods of time. Users of this specification are advised to consider the commentary on this topic in Appendix X1.

1.4 This specification primarily considers end use in dry service conditions, such as with most protected framing members, where the average equilibrium moisture content for solid-sawn lumber is less than 16 %. The conditioning environment of 6.3 is considered representative of such uses.

1.5 The performance of structural composite lumber is affected by wood species, wood element size and shape, and adhesive and production parameters. Therefore, products produced by each individual manufacturer shall be evaluated to determine their product properties, regardless of the similarity in characteristics to products produced by other manufacturers. Where a manufacturer produces product in more than one facility, each production facility shall be evaluated independently. For additional production facilities, any revisions to the full qualification program in accordance with this specification shall be approved by the independent qualifying agency.

¹ This specification is under the jurisdiction of ASTM Committee D07 on Wood and is the direct responsibility of Subcommittee D07.02 on Lumber and Engineered Wood Products.

Current edition approved Oct. 15, 2012; May 1, 2013. Published November 2012; July 2013. Originally approved in 1993. Last previous edition approved in 2011 as D5456 – 11; D5456 – 12. A. DOI: 10.1520/D5456-12.10.1520/D5456-13.

1.6 This specification is intended to provide manufacturers, regulatory agencies, and end users with a means to evaluate a composite lumber product intended for use as a structural material.

1.7 This specification covers initial qualification sampling, mechanical and physical tests, analysis, and design value assignments. Requirements for a quality-control program and cumulative evaluations are included to ensure maintenance of allowable design values for the product.

1.8 This specification, or parts thereof, shall be applicable to structural composite lumber portions of manufactured structural components.

1.9 The values stated in inch-pound units are to be regarded as standard. The values given in parentheses are mathematical conversions to SI units that are provided for information only and are not considered standard.

1.10 *This standard does not purport to address all of the safety concerns, if any, associated with its use. It is the responsibility of the user of this standard to establish appropriate safety and health practices and determine the applicability of regulatory limitations prior to use.*

2. Referenced Documents

2.1 ASTM Standards:²

- [C177 Test Method for Steady-State Heat Flux Measurements and Thermal Transmission Properties by Means of the Guarded-Hot-Plate Apparatus](#)
- [C384 Test Method for Impedance and Absorption of Acoustical Materials by Impedance Tube Method](#)
- [C423 Test Method for Sound Absorption and Sound Absorption Coefficients by the Reverberation Room Method](#)
- [D9 Terminology Relating to Wood and Wood-Based Products](#)
- [D143 Test Methods for Small Clear Specimens of Timber](#)
- [D150 Test Methods for AC Loss Characteristics and Permittivity \(Dielectric Constant\) of Solid Electrical Insulation](#)
- [D198 Test Methods of Static Tests of Lumber in Structural Sizes](#)
- [D245 Practice for Establishing Structural Grades and Related Allowable Properties for Visually Graded Lumber](#)
- [D669 Test Method for Dissipation Factor and Permittivity Parallel with Laminations of Laminated Sheet and Plate Materials \(Withdrawn 2012\)³](#)
- [D1037 Test Methods for Evaluating Properties of Wood-Base Fiber and Particle Panel Materials](#)
- [D1583 Test Method for Hydrogen Ion Concentration of Dry Adhesive Films](#)
- [D1666 Test Methods for Conducting Machining Tests of Wood and Wood-Base Panel Materials](#)
- [D1761 Test Methods for Mechanical Fasteners in Wood](#)
- [D2132 Test Method for Dust-and-Fog Tracking and Erosion Resistance of Electrical Insulating Materials](#)
- [D2394 Test Methods for Simulated Service Testing of Wood and Wood-Base Finish Flooring](#)
- [D2395 Test Methods for Specific Gravity of Wood and Wood-Based Materials](#)
- [D2559 Specification for Adhesives for Bonded Structural Wood Products for Use Under Exterior Exposure Conditions](#)
- [D2718 Test Methods for Structural Panels in Planar Shear \(Rolling Shear\)](#)
- [D2915 Practice for Sampling and Data-Analysis for Structural Wood and Wood-Based Products](#)
- [D3201 Test Method for Hygroscopic Properties of Fire-Retardant Wood and Wood-Based Products](#)
- [D3755 Test Method for Dielectric Breakdown Voltage and Dielectric Strength of Solid Electrical Insulating Materials Under Direct-Voltage Stress \(Withdrawn 2013\)³](#)
- [D4300 Test Methods for Ability of Adhesive Films to Support or Resist the Growth of Fungi](#)
- [D4442 Test Methods for Direct Moisture Content Measurement of Wood and Wood-Base Materials](#)
- [D4761 Test Methods for Mechanical Properties of Lumber and Wood-Base Structural Material](#)
- [D4933 Guide for Moisture Conditioning of Wood and Wood-Based Materials](#)
- [D5055 Specification for Establishing and Monitoring Structural Capacities of Prefabricated Wood I-Joists](#)
- [D5457 Specification for Computing Reference Resistance of Wood-Based Materials and Structural Connections for Load and Resistance Factor Design](#)
- [D5764 Test Method for Evaluating Dowel-Bearing Strength of Wood and Wood-Based Products](#)
- [D6815 Specification for Evaluation of Duration of Load and Creep Effects of Wood and Wood-Based Products](#)
- [D7247 Test Method for Evaluating the Shear Strength of Adhesive Bonds in Laminated Wood Products at Elevated Temperatures](#)
- [D7480 Guide for Evaluating the Attributes of a Forest Management Plan](#)
- [E84 Test Method for Surface Burning Characteristics of Building Materials](#)
- [E96/E96M Test Methods for Water Vapor Transmission of Materials](#)

² For referenced ASTM standards, visit the ASTM website, www.astm.org, or contact ASTM Customer Service at service@astm.org. For *Annual Book of ASTM Standards* volume information, refer to the standard's Document Summary page on the ASTM website.

³ The last approved version of this historical standard is referenced on www.astm.org.

E119 Test Methods for Fire Tests of Building Construction and Materials

2.2 CSA Standards:⁴

CSA Standards for Wood Adhesives O112-M Series

CSA O325 Construction Sheathing

2.3 Other Standard Standards:

ISO/IEC 17020 General Criteria for the Operation of Various Types of Bodies Performing Inspection⁵

US Product Standard PS 2 Performance Standard for Wood-Based Structural-Use Panels

3. Terminology

3.1 Definitions—Standard definitions of wood terms are given in Terminology D9.

3.2 Definitions of Terms Specific to This Standard:

3.2.1 Exposure 1 durability—a bond classification for wood-based products that are not permanently exposed to the weather.

⁴ Available from Canadian Standards Association (CSA), 5060 Spectrum Way, Mississauga, ON L4W 5N6, Canada, <http://www.csa.ca>.

⁵ Available from International Organization for Standardization (ISO), 1, ch. de la Voie-Creuse, CP 56, CH-1211 Geneva 20, Switzerland, <http://www.iso.org>.

3.2.1.1 Discussion—

Wood-based products classified as Exposure 1 are intended to resist the effects of moisture on structural performance due to construction delays or other conditions of similar severity.

3.2.2 structural composite lumber (SCL)—in this specification, structural composite lumber (SCL) is any of laminated veneer lumber (LVL), parallel strand lumber (PSL), laminated strand lumber (LSL), oriented strand lumber (OSL), or laminated veneer bamboo (LVB), which are intended for structural use and bonded with an exterior adhesive.

3.2.2.1 laminated strand lumber (LSL)—a composite of wood strand elements with wood fibers primarily oriented along the longitudinal axis of the member, where the least dimension of the wood strand elements is 0.10 in. (2.54 mm) or less and their average lengths are a minimum of 150 times the least dimension of the wood strand elements.

3.2.2.2 laminated veneer bamboo (LVB)—a composite of bamboo strand elements, edge-bonded to form veneer sheets which are then face-bonded to form finished products, with bamboo fibers primarily oriented along the longitudinal axis of the member where the least dimension of strand elements is 0.25 in. (6.4 mm) or less and their average strand lengths are a minimum of 300 times the least dimension of the bamboo strand elements (see X1.2).

3.2.2.3 laminated veneer lumber (LVL)—a composite of wood veneer sheet elements with wood fibers primarily oriented along the longitudinal axis of the member, where the veneer element thicknesses are 0.25 in. (6.4 mm) or less.

3.2.2.4 oriented strand lumber (OSL)—a composite of wood strand elements with wood fibers primarily oriented along the longitudinal axis of the member, where the least dimension of the wood strand elements is 0.10 in. (2.54 mm) or less and their average lengths are a minimum of 75 times the least dimension of the wood strand elements.

3.2.2.5 parallel strand lumber (PSL)—a composite of wood veneer strand elements with wood fibers primarily oriented along the longitudinal axis of the member, where the least dimension of wood veneer strand elements is 0.25 in. (6.4 mm) or less and their average lengths are a minimum of 300 times the least dimension of the wood veneer strand elements.

3.2.3 Discussion—SCL has three mutually perpendicular directions of orientation (see Fig. 1):

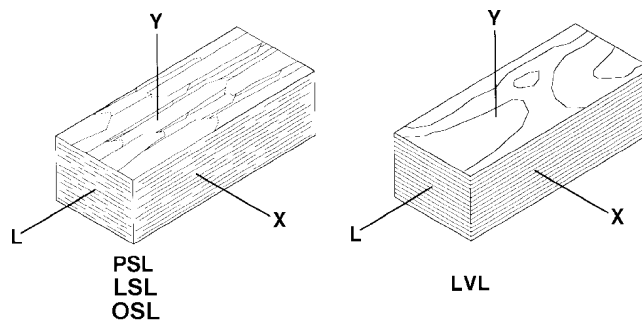

FIG. 1 Orientations for Structural Composite Lumber

L Direction—Parallel to the longitudinal direction of the member.

X Direction—Parallel to a surface of the member and normal to the L direction.

Y Direction—Normal to both L and X direction.

In this specification, longitudinal shear means shear stress in the *L-X* and *L-Y* planes. Planar shear is stress in the *X-Y* plane.

3.2.4 SCL adhesive, *n*—a material used for adhesion in the manufacturing of SCL products, which could be an SCL binder or non-binder adhesive.

3.2.5 SCL binder adhesive, *n*—an adhesive that bonds wood elements, such as flakes, strands, particles, or fibers, of SCL products and usually does not form a continuous bondline.

3.2.5.1 Discussion—

Current examples of SCL binders include those systems used in the production of LSL and OSL.

3.2.6 SCL non-binder adhesive, *n*—an adhesive that bonds wood elements, such as veneers and veneer strand elements, of SCL products that is intended to completely cover all of the gluing surfaces.

3.2.6.1 Discussion—

Current examples of SCL non-binder adhesives include those systems used in the production of LVL, PSL and LVB.

4. Materials

4.1 *General*—Structural composite lumber materials conforming to this specification meet the definition of a bio-based product in accordance with 3.3.1 of Guide **D7480**.

4.2 *Wood Elements*—Wood elements used in the fabrication of SCL products shall conform to **3.2**.

4.3 *Adhesives*—~~Adhesives~~ Adhesives used in the fabrication of SCL products shall conform to the requirements in Specification **D2559**. ~~Alternatively, the durability of high temperature curing adhesives can be evaluated with the procedures specified in Annex A4.2 (see Note 2). For this procedure, the average strength retention shall be at least 50 %. In Canada, adhesives shall conform to the appropriate section of CSA Standards for Wood Adhesives, O112-M Series, except that the LVB adhesives shall be based on the criteria for hardwood species. In addition, adhesives used for LVL and PSL shall be qualified for heat durability performance in accordance with 4.3.1. X1.2.4 provides additional information.~~

4.3.1 Non-Binder Adhesives—Non-binder adhesives used in the fabrication of SCL products shall conform to the requirements in Specification **D2559**. In Canada, non-binder adhesives shall conform to the appropriate section of CSA Standards for Wood Adhesives, O112-M Series, except that the LVB adhesives shall be based on the criteria for hardwood species.

NOTE 2—Adhesives evaluated by Annex **A4.2** are only qualified for Exposure 1 conditions; other conditions are beyond the scope of this specification. See the commentary and the section on Design and Mechanical Property Concerns in **Appendix X1** for further information.

4.3.2 Binder Adhesive—Binder adhesives, when used, shall be evaluated to meet the requirements specified in **Annex A5** (see **Note 2**). <https://standards.iteh.ai/catalog/standards/sist/62572be4-95ff-44ea-9510-ef777afbb2eb/astm-d5456-13>

NOTE 2—**Annex A5** requirements meet or exceed the requirements for Exposure 1; other conditions are beyond the scope of this specification. See the commentary and the section on Design and Mechanical Property Concerns in **Appendix X1** for further information.

NOTE 3—Heat durable performance implies that the bond between wood elements (veneers in LVL and strands in PSL) will exhibit similar material resistance to solid wood in an elevated temperature environment where the wood material surrounding the bond does not provide thermal protection.

4.3.3 Non-Binder and Binder Adhesives—All adhesives used for SCL shall be qualified for heat durability performance in accordance with **4.3.4**. **X1.2.4** provides additional information.

NOTE 3—Heat durable performance implies that the bond between wood elements will permit the SCL to exhibit similar performance characteristics as solid wood in an elevated temperature environment.

4.3.4 Adhesive Heat Durability:

4.3.4.1 Adhesives used for LVL and PSL shall be qualified for heat durability performance through testing in accordance with Test Method **D7247**. The test temperature and heat exposure duration for specimens tested at elevated temperature (Section 7.2 of Test Method **D7247**) shall meet the requirements of Items (1),(2),(3), and (4) below.

(1) The solid wood control specimens and bonded specimens shall be prepared from the same wood species of either Douglas Fir, Southern Pine, or the predominate species used in the LVL or PSL product, provided the same adhesive formulation is used for these wood species.

(2) For the bonded specimens, the minimum target bondline temperature shall be 428°F (220°C). For the matched solid wood control specimens, the minimum target temperature at the shear plane shall be 428°F (220°C).

(3) The minimum target temperatures of Item (1) shall be maintained for a minimum of 10 min or until achieving a residual strength ratio for the solid wood control specimens of $30 \pm 10 \%$, whichever is longer.

(4) Block shear testing shall be conducted immediately after removal from the oven such that the specimen bondline or shear plane temperature does not drop more than 9°F (5°C) after leaving the oven and prior to failure. This provision is satisfied when the time interval from the removal of the specimen from the oven to the failure of the block shear specimen does not exceed 60 s for each specimen tested and the room temperature of the test laboratory at the time of testing is not less than 60°F (15.5°C).

4.3.4.2 The adhesive used for LSL and OSL shall be qualified for heat durability performance through testing in accordance with Test Method **D7247** except that homogeneous pieces of LSL or OSL product shall be used in lieu of solid sawn face bonded specimens. The solid wood control species, LSL or OSL grade, test orientation of LSL and OSL, test temperature and heat exposure duration for specimens tested at elevated temperature (Section 7.2 of Test Method **D7247**) shall meet the requirements of Items (1), (2), (3), (4), (5), and (6) below.

(1) The solid wood control specimens shall be: Douglas Fir, Southern Pine, or the predominate species used in the LSL or OSL product. Each piece of solid wood used as part of this test method shall have a specific gravity equal to or exceeding the value specified in the National Design Specification.

(2) The highest grade of the LSL or OSL products shall be tested.

(3) The LSL and OSL specimen shear tests shall be conducted in the L-X plane and shall be loaded parallel to the wood grain or strands.

(4) For the LSL and OSL specimens, the minimum target bondline or shear plane temperature shall be 428°F (220°C). For the solid wood control specimens, the minimum target temperature at the shear plane shall be 428°F (220°C).

(5) The minimum target temperatures of Item (4) shall be maintained for a minimum of 10 min or until achieving a residual strength ratio for the solid wood control specimens of $30 \pm 10\%$, whichever is longer.

(6) Block shear testing shall be conducted immediately after removal from the oven such that the specimen bondline or shear plane temperature does not drop more than 9°F (5°C) after leaving the oven and prior to failure. This provision is satisfied when the time interval from the removal of the specimen from the oven to the failure of the block shear specimen does not exceed 60 s for each specimen tested and the room temperature of the test laboratory at the time of testing is not less than 60°F (15.5°C).

4.3.4.3 For adhesives tested in accordance with **4.3.1-14.3.4.1** and **4.3.1-24.3.4.2**, the residual shear strength ratio for the bonded specimens, as calculated in accordance with Test Method **D7247**, shall be equal to or higher than the lower 95 % confidence interval on the mean residual shear strength ratio for the solid wood control specimens.

NOTE 4—The ability of the acceptance criteria to detect a heat-sensitive binder system may depend on the strand thickness or strand alignment, or both. Additional consideration may be warranted for products with large strand thickness or strands that are substantially not aligned with the test specimen shear plane, or both.

5. Mechanical Properties

5.1 The characteristic value for SCL is a statistic derived from test data as specified in **7.1**. For bending and tension parallel to grain, the characteristic value is obtained at the unit volume as specified in **6.5.1** and **6.5.2**.

5.2 The design stress related to SCL is derived from the characteristic value through application of the adjustments listed in **Table 1** of this specification.

TABLE 1 Adjustment Factors

NOTE 1—Apparent modulus of elasticity is computed from a deformation, and compression strength perpendicular to grain is established at a deformation limit. Neither is subject to load duration adjustments. All other factors are the product of 1.62, that adjusts data to normal duration as defined in 7.3.1 of Practice **D245**, and an additional factor for uncertainty (see **Appendix X3** for an explanation of the shear block test adjustment factor).

Property	Adjustment Factor
Apparent modulus of elasticity	1.00
Bending strength	2.10
Tensile strength parallel to grain	2.10
Compressive strength parallel to grain	1.90
Longitudinal shear strength	
Shear block test	3.15
Structural-size shear test	2.10
Compressive strength perpendicular to grain	1.67

5.3 The allowable design stress published for engineering use shall be derived from the design stress modified by factors given in **7.3**.

6. Qualification

6.1 Samples for qualification testing shall be representative of the population being evaluated. When an intentional modification to the process results in a reduction in mechanical properties as indicated by the quality-control program, then new qualification is required.

6.1.1 Qualification tests shall be conducted or witnessed by a qualified agency in accordance with **8.1**. All test results are to be certified by the qualified agency.

6.2 Sampling of the test material shall be done in accordance with applicable portions of the section on Statistical Methodology of Practice **D2915**.

6.2.1 Design stress, except for compression perpendicular to grain and apparent modulus of elasticity, shall be based on the 5th percentile tolerance limit.

6.2.2 The confidence level for calculating tolerance limits and confidence intervals shall be 75 %.

6.2.3 Minimum sample size for calculating tolerance limits on 5th percentiles shall be 53. When volume effect tests are made at multiple sizes for bending and tension, the minimum sample shall be 78 specimens at the unit volume specimen size.

6.2.3.1 The calculated 5th percentile parametric tolerance limits (PTL) shall have a standard error no greater than 5 % of the PTL, when evaluated in accordance with 3.4.3.2 of Practice **D2915**. When necessary, the sample shall be increased beyond the minimum of 53, to meet this requirement.

6.2.4 Minimum unit sample sizes for compression perpendicular to grain (see **6.5.4**) shall provide estimation of mean values within 5 % in accordance with 3.4.2 of Practice **D2915**. Minimum sample size shall not be less than 30.

6.3 Composite lumber used in qualification testing shall be brought to moisture equilibrium in a conditioned environment of 68 ± 11°F (20 ± 6°C) and 65 % (±5 %) relative humidity. Methods for determination of completion of conditioning are given in Guide **D4933**.

6.4 Moisture content and specific gravity shall be measured and reported for each specimen tested in the qualification program. Measurement for moisture content shall be in accordance with Test Methods **D4442** and measurement of specific gravity shall be in accordance with Test Methods **D2395**.

6.5 *Mechanical Properties*—The properties that shall be evaluated by qualification testing shall include, but are not limited to: bending strength and stiffness, tensile strength parallel to the grain, compressive strength parallel to the grain, compressive strength perpendicular to the grain, and longitudinal shear strength.

6.5.1 *Bending*—Modulus of rupture and apparent modulus of elasticity shall be determined for both flatwise and edgewise bending in accordance with principles of Test Methods **D198** or **D4761**. Specimen cross section shall not be less than the minimum anticipated structural size. Selection of specimen dimensions establishes the unit volume for the analysis of **7.4.1**. Loading at third points and a span-to-depth ratio in the range from 17 to 21 shall be used for flatwise and edgewise bending.

NOTE 5—A span-to-depth ratio of 18 is a frequent international standard.

6.5.1.1 When either or both the size and moisture content of the qualification specimens will differ from specimens to be tested in quality control, the bending tests of **6.5.1** shall also be conducted on specimens of the size and the moisture content that will prevail at the time of routine quality-control testing. The specimens representing the quality-control conditions shall be matched with those to be conditioned (see **6.3**). The ratio of the means of both strength and stiffness shall be used to adjust quality-control test results to the qualification level, for use in the confirmation required in **10.6.1**.

6.5.1.2 Moisture content is recognized as different when the discrepancy between the average of the two test sets is one percentage point of moisture content or more. Sample size shall be the same for both test sets and not less than 78.

6.5.1.3 If testing is required in accordance with **6.5.1.1**, the coefficient of variation of the bending strength from those tests shall be the basis for comparison required in **10.6.3**. Otherwise, the coefficient of variation of the bending strength from the tests in **6.5.1** shall be the basis.

6.5.2 *Tension Parallel to Grain*—Tension strength parallel to grain shall be tested in accordance with principles of Test Methods **D198** or **D4761**. Specimen cross section shall not be less than the minimum anticipated structural size. Specimen length shall provide for a minimum length of 36 in. (915 mm) between grips. Selection of specimen dimensions establishes the unit volume for the analysis of **7.4.1**.

6.5.2.1 When either or both the size and moisture content of the qualification specimens will differ from specimens to be tested in quality control, the tension tests of **6.5.2** shall also be conducted on specimens of the size and the moisture content that will prevail at the time of routine quality-control testing. The specimens representing the quality-control conditions shall be matched with those to be conditioned (see **6.3**). The ratio of the means of strength shall be used to adjust quality-control test results to the qualification level, for use in the confirmation required in **10.6.1**. Moisture content is recognized as different when the discrepancy between the average of the two test sets is one percentage point of moisture content or more. Sample size shall be the same for both test sets and not less than 78.

6.5.2.2 If testing is required in accordance with **6.5.2.1**, the coefficient of variation of the tensile strength from those tests shall be the basis for comparison required in **10.6.3**. Otherwise, the coefficient of variation of the tensile strength from the tests in **6.5.2** shall be the basis.

6.5.3 *Compression Parallel to Grain*—Short-column compression strength parallel to grain shall be determined in accordance with principles of Test Methods **D198** or **D4761**. Minimum cross section shall be 1.5 by 1.5 in. (38 by 38 mm). Length of the specimen shall be such that L/r is less than 17 and greater than 15, where L is the effective unsupported length and r is the least radius of gyration.

6.5.4 *Compression Perpendicular to Grain*—Compressive strength perpendicular to grain shall be determined in accordance with principles of Test Methods **D143** except that references to placement of growth rings are not applicable and minimum

cross-section dimension is 1.5 in. (38 mm). Stress at both 0.02 and 0.04-in. (0.5 and 1.0-mm) deformation shall be reported. Testing shall be done with stresses applied normal to the *L-X* plane in one test series and to the *L-Y* plane in another series.

6.5.5 *Longitudinal Shear*—Longitudinal shear strength in the *L-Y* plane shall be determined by conducting ASTM block shear tests or structural-size horizontal shear tests. Longitudinal shear strength in the *L-X* plane shall be determined by conducting ASTM block shear tests. When evaluating the effect of systematic manufacturing characteristics that might affect horizontal shear strength, the structural size horizontal shear test method shall be used (see [Annex A3](#)).

6.5.5.1 ASTM block shear tests shall be conducted in accordance with principles of Test Methods [D143](#) except that a minimum dimension of 1.5 in. (38 mm) at the shear area is acceptable provided that the total shear area is 4 in.² (2580 mm²).

6.5.5.2 Structural-size horizontal shear tests in the *L-Y* plane shall be conducted in accordance with the procedures specified in [Annex A3](#) of this specification.

6.5.5.3 If anticipated end use involves shear perpendicular to grain on a face of the material (planar shear), testing shall establish allowable shear stress in accordance with the principles of Test Method [D2718](#).

6.6 *Shear Modulus*—Shear modulus (*G*) for LVB shall be determined and reported in accordance with Test Methods [D198](#). The shear deformation shall be considered in the total deflection calculation.

6.7 *Bond Quality:*

6.7.1 *Internal Bond*—For bond quality evaluation of PSL, LSL, and OSL, internal bond shall be tested and reported in accordance with Test Methods [D1037](#) (see [Note 6](#)), except that the tests shall be done at a constant rate of displacement such that the average time-to-failure is not less than 1 min. The minimum sample size shall not be less than 50 test specimens taken from multiple cross-sections and locations.

6.7.2 For LVL, the glue bond quality shall be evaluated in accordance with [6.5.5](#) in the *L-X* plane except that the percentage of wood failure shall be evaluated and reported.

6.7.3 [A4.2](#) provides an optional adhesive durability test method that a manufacturer shall be permitted to use as a means to evaluate bond durability for quality assurance or product optimization. [A4.2](#) is not intended for adhesive qualification testing as required in [Annex A5](#).

6.7.4 For LVB, the glue bond quality shall be evaluated in accordance with [6.5.5](#) in the *L-X* and *L-Y* planes except that the percentage of fiber failure shall be evaluated and reported.

6.8 *Product Durability:*

6.8.1 *Edgewise Bending Durability*—For all SCL products, edgewise bending durability shall be conducted in accordance with [A4.3](#). The average strength retention shall be at least 75 %.

6.8.2 *Lateral Edge Nail Durability*—For PSL, LSL, OSL, and LVB, lateral edge (*X-L*) nail durability shall be evaluated in accordance with [A4.4](#). The average strength retention shall be at least 75 %.

6.9 *Physical Properties:*

6.9.1 *Thickness Swell*—For PSL, LSL, OSL, and LVB, thickness swell shall be tested and reported in accordance with Test Methods [D1037](#) (see [Note 6](#)). The minimum sample size shall not be less than 25 test specimens taken from multiple cross-sections and locations.

NOTE 6—Test Methods [D1037](#) specifies that the test thickness shall be that of the finished board. Some SCL products are manufactured in thicknesses greater than those intended for evaluation by the procedures in Test Methods [D1037](#). It may be necessary to limit the test thickness for PSL products that are manufactured in thicknesses greater than 3.5 in. (89 mm).

6.9.2 *Density Gradient Through the Thickness*—For LSL and OSL, density gradient through the thickness shall be tested and reported in accordance with [A4.5](#).

6.9.3 *Other Physical Properties*—Other physical properties shall be assessed when they affect end use. Information on other physical properties and related standards is given in [Appendix X1](#).

7. Determination of Allowable Design Stresses

7.1 Allowable design values developed in this section are consistent with engineering practice in building construction. Their applicability in other types of structures has not been evaluated and such applications require independent evaluation.

7.2 *Characteristic Value*—In the derivation of the characteristic value, the procedures in the sections on Statistical Methodology and Analysis and Presentation of Results of Practice [D2915](#) shall be followed, except that provisions of this specification govern where differences occur.

7.2.1 The 5th percentile tolerance limit (TL) with 75 % confidence from test results of [6.5](#) shall be the characteristic value for strengths in flexure, tension parallel to grain, compression parallel to grain, and longitudinal shear.

7.2.1.1 Parametric or nonparametric analysis shall be performed to obtain a 5th percentile tolerance limit.

7.2.1.2 For parametric analysis either the normal or lognormal distribution shall be used to establish a 5th percentile tolerance limit with 75 % confidence. The distribution selection shall be based on standard statistical goodness of fit tests. As a minimum, the fit selection shall include visual inspection of cumulative frequency plots of the fitted distributions with the data and the lesser of standard errors of the estimate from the two distributions fitted by the method of least squares.

NOTE 7—Experience has shown that data from SCL typically has coefficients of variation (COV) less than 20 % and are symmetrical to slightly right skewed and, therefore, are reasonably described by the normal and lognormal distributions. Goodness of fit references are given in Note 6 of Practice D2915. The minimum procedures of 7.2.1.2 are detailed in X4.7 of Specification D5055.

7.2.2 The average value for apparent modulus of elasticity from test results of 6.5.1 shall be the characteristic value for apparent modulus of elasticity.

7.2.3 The average value at 0.04-in. (1.0-mm) deformation for compression perpendicular to grain from test results of 6.5.4 shall be the characteristic value for compression perpendicular to grain.

7.3 *Design Stresses*—Design stresses shall be calculated from the characteristic value defined in 7.2 in accordance with the following formula:

$$S = \frac{B}{C_a} \quad (1)$$

where:

S = design stress,

B = characteristic value, and

C_a = adjustment factor from Table 1.

7.4 *Allowable Design Stress*—Design stresses shall be modified by factors that consider the end-use applications as follows:

$$F_a = C_e S \quad (2)$$

where:

F_a = allowable design stress,

C_e = product of end use (K) factors, and

S = design stress.

Factors common to all members are detailed in this section.

7.4.1 *Volume Factors*:

7.4.1.1 Strength properties are affected by the relative volume at a given stress. For purposes of this section, the members tested in edge bending or axial tension in Section 6 shall be taken as a unit volume. Sections other than solid rectangles, or solid rectangular sections not loaded axially or normal to one of its surfaces, require special investigation.

7.4.1.2 Volume factors shall either be determined from the prescribed theoretical relationships or by testing on a range of sizes, as detailed in Annex A1.

7.4.1.3 *Bending*—Bending design stress shall be adjusted for volume effect by multiplication with the factor as follows:

$$K_d = \left(\frac{d_1}{d}\right)^{2m} = \left(\frac{d_1}{d}\right)^{1n} \quad (3)$$

where:

K_d = factor applied to design stress of the member of unit volume,

d_1 = depth of unit volume members,

d = depth of an application member,

m = a parameter determined in accordance with Annex A1, and

n = $m/2$

NOTE 8—A derivation of Eq 3 is given in Ref (1)⁶ along with example data. In this case, volume considered is only two-dimensional since, at least within the limits given in Annex A1, increasing width of SCL bending members does not result in strength reduction. In some cases, tests show a strength increase with increasing width, possibly because of greater stability along the compression edge. Therefore the two-dimensional form of the equation is of the form $K_d = (d_1/d)^{1/m} (L_1/L)^{1/m}$ where L_1 and L are the length of the unit volume and application member, respectively. When a constant span/depth ratio is assumed, Eq 3 becomes $K_d = (d_1/d)^{2/m}$, which can be further simplified to $K_d = (d_1/d)^{1/n}$, where $n = m/2$.

7.4.1.4 *Axial Tension*—Tensile design stress shall be adjusted for volume by multiplication with factor as follows:

$$K_L = \left(\frac{L_1}{L}\right)^{1/m} \quad (4)$$

where:

K_L = adjustment factor,

L_1 = base length between grips tested in 6.5.2,

L = end-use length, and

m = parameter determined in accordance with Annex A1.

NOTE 9—Tension tests of SCL do not show strength reductions for increasing cross section so that volume is represented by length alone. Annex A1 states criteria for accepting this approach without limitations. Ref (1) gives example data.

⁶ The boldface numbers in parentheses refer to a list of references at the end of this standard.

7.4.1.5 When volume effect factors are based on single-size testing in accordance with **A1.2.3**, increased design stresses for members smaller than that tested are not permitted.

7.4.1.6 Other related conditions that influence the bending strength of a member include the loading diagram and support condition. Adjustments for common load cases are given in **Annex A1** and other information is found in Ref (2).

7.4.2 Duration of Load/Creep Effects:

7.4.2.1 Duration of load and creep effects shall be evaluated in accordance with Specification **D6815**. As a minimum, one representative grade per adhesive classification shall be evaluated. It is the responsibility of the manufacturer and the certified agency to determine which representative grade and what species or species combination shall be evaluated by considering the density and gluing characteristics of the species or species combination. Chapter 9 of the Wood Handbook (3) provides additional guidance.

NOTE 10—For products manufactured with one or more species, either separately or mixed, the greatest anticipated percentage(s) of the highest density species should be evaluated (see **Appendix X1**).

7.4.2.2 The allowable design stresses developed in this specification correspond to the condition of normal loading as defined in 7.3 of Practice **D245** provided the product demonstrates acceptable long-term load performance as determined in accordance with Specification **D6815**. These stresses shall be adjusted for other loading durations using the same factors applied to sawn lumber and other wood and wood-based structural members, as defined in Ref (4).

7.4.3 Allowable design stresses developed in this specification are for use in dry conditions as defined in 1.4. If use at other moisture conditions is intended, a documented test-based investigation leading to appropriate properties adjustment must be carried out.

7.4.4 *Other End-Use Adjustments*—In some cases, end use requires other adjustments. A brief discussion of such use conditions is given in **Appendix X1**.

7.5 To convert allowable design stresses to load and resistance factor design (LRFD) format, use the procedures of Specification **D5457**.

8. Independent Inspection

8.1 A qualified agency shall be employed by the manufacturer to audit the quality assurance program and inspect the production process of the plant without prior notification or with minimal prior notification. The audit and inspection shall include review and approval of the plant's quality assurance program and inspection of randomly selected products and QC data. When production is sporadic, the qualified agency shall communicate with the manufacturer to schedule inspections to coincide with production.

8.2 *Qualified Agency*—A qualified agency is defined to be one that:

8.2.1 Has been accredited by an International Accreditation Forum (IAF) member accreditor as meeting ISO/IEC 17020 requirements;

8.2.2 Has access to the facilities and trained technical personnel to verify that the grading, measuring, species, construction, bonding, workmanship, and other characteristics of the products as determined by inspection, sampling, and testing comply with all applicable requirements specified in this specification;

8.2.3 Has procedures to be followed by its personnel in performance of the inspection and testing;

8.2.4 Has no financial interest in, or is not financially dependent upon, any single company manufacturing the product being inspected or tested; and

8.2.5 Is not owned, operated, or controlled by any such company.

9. Manufacturing Standard

9.1 A manufacturing standard, subject to the approval of the qualified agency, shall be written and maintained by the manufacturer for each product and each production facility. This specification shall include provision for quality assurance.

10. Quality Assurance

10.1 *Quality Assurance in Manufacturing Standard*—This portion of the manufacturing standard shall include subject matter necessary to the quality-assurance program including the following:

10.1.1 Material specifications, including incoming material inspection and acceptance requirements, and

10.1.2 Quality assurance, inspection, testing, and acceptance procedures.

10.1.2.1 Sampling and inspection frequencies shall be devised to encompass all variables that affect the quality of the finished product. Increased frequencies shall be used in connection with new or revised facilities. A random sampling scheme shall generally be used for specimen selection.

NOTE 11—Increased sampling and test frequency is a useful procedure when investigating apparent data trends or adjustments in the process. It is desirable at times to deviate from a random sampling scheme while investigating effects of specific variables.

10.1.3 Procedures to be followed upon failure to meet specifications or upon out-of-control conditions shall be specified. Included shall be reexamination criteria for suspect material and material rejection criteria.

10.1.4 Finished product marking, handling, protection, and shipping requirements as they relate to the performance quality of the product shall be defined.

10.2 *Inspection Personnel*—All manufacturing personnel responsible for quality control shall demonstrate to the qualified agency that they have knowledge of the inspection and test procedures used to control the process of the operation and calibration of the recording and test equipment used and of the maintenance and interpretation of quality-control records.

10.2.1 Use of quality-control records beyond quality control, for monitoring and adjusting allowable design values, requires special recognition. The independent inspection agency and manufacturing quality-control personnel must maintain continuing awareness of this additional responsibility.

10.3 *Record Keeping*—All pertinent records shall be maintained on a current basis and be available for review by the qualified agency personnel. As a minimum, such records shall include:

10.3.1 All inspection reports and records of test equipment calibration, including identification of personnel carrying out the tests;

10.3.2 All test data, including retests and data associated with rejected production; and

10.3.3 Details of any corrective actions taken and the disposition of any rejected production resulting from tests or inspections.

10.4 *Quality Assurance Testing*:

10.4.1 *Testing Equipment*—Testing equipment is to be properly maintained, calibrated, and evaluated for accuracy and adequacy at a frequency satisfactory to the qualified agency.

10.4.2 *Required Tests*—The following shall be considered to be the scope of a minimum testing program:

10.4.2.1 The bending test described in 6.5.1 shall be used for quality assurance of bending strength and stiffness.

10.4.2.2 The tension test described in 6.5.2 shall be used for quality assurance of tensile strength parallel to grain.

10.4.2.3 Moisture content data shall be determined by the same process as in 6.4, at a frequency that provides a representative sample of production.

10.4.2.4 Bond quality, product durability, and physical property tests described in 6.7.1, 6.8.1, 6.9.1, and 6.9.2 shall be used for quality assurance when applicable.

10.4.2.5 When required, quality assurance data shall be adjusted by the factors of 6.5.1.1 and 6.5.2.1 prior to further analysis.

10.4.2.6 Test frequency for all tests shall be chosen to yield quality-assurance performance that is consistent with design stresses assigned to the product and its intended use.

10.5 *Process Control*:

10.5.1 Prior to shipping material represented by the Q.A. sample, data from the tests of 10.4 shall be evaluated to confirm that the material properties are in statistical control. The control level selected shall be consistent with current design values and intended use of the material. For PSL, LSL, and OSL, internal bond quality in accordance with 6.7.1 shall also be evaluated prior to shipping material.

NOTE 12—References (5-7) provide useful background material on quality control.

10.5.2 When the analysis of 10.5.1 indicates that the material properties are below the control level, the associated portion of production shall be subject to reexamination in accordance with acceptance procedures of 10.1.3.

10.6 *Cumulative Evaluation*:

10.6.1 *Design Stresses*—Periodically, characteristic values and associated allowable stress values shall be formally checked using data accumulated in 10.4. At least one such check shall be made in the first six months of operation involving new production or from any new product line. Thereafter, analysis shall be conducted at intervals not to exceed one year.

10.6.2 *Analysis*—The periodic analysis shall be conducted in accordance with 7.1-7.3. All data from the period associated with statistical process control shall be included in the analysis.

10.6.2.1 Design values must be affirmed by the analysis of 10.6.2 or be reduced accordingly.

10.6.2.2 When design values have been reduced in accordance with 10.6.2.1 or at the option of the producer because of excessive reject rates, a new statistical process control level in keeping with the new design value shall be established. The evaluation then includes all data from the period in statistical control based upon the new control level.

10.6.3 *Volume Effect*—If the coefficient of variation of bending strength, as computed directly from data analysis in 10.6.2, has increased by one and one-half percentage points or more over corresponding values determined in 6.5.1 or 6.5.2, the parameter (m) in Eq 3 and Eq 4 shall be recomputed using Eq A1.1.

11. Keywords

11.1 accelerated aging; allowable design stresses; binder; durability; mechanical properties; non-binder; quality assurance; structural composite lumber

A1. VOLUME EFFECT PARAMETER DETERMINATION
A1.1 Scope

A1.1.1 **Annex A1** covers procedures that shall be used to determine the exponent in **Eq 3** and **Eq 4**. Sections **A1.2** and **A1.3** define, for bending and tension respectively, the value of the exponent for single-size test data and the sampling procedures for multiple size testing. Section **A1.4** gives a uniform procedure for processing multiple-size test data to determine the exponent for both bending and tension, experimentally.

A1.1.2 Limits on extrapolation beyond test data are given in **A1.2.2** and apply to either single or multiple size specimen tests. Extrapolation beyond testing is not limited in tension, provided the requirements of **A1.3.2** are met.

A1.2 Flexure

A1.2.1 If test data for only one specimen size are available as specified in **6.5.1** as a minimum requirement, the value of (m), **Eq 3**, **7.4.1.3**, is given in **A1.2.3** by specific formulation.

A1.2.2 Thicknesses greater than three times the maximum tested in **6.5.1** or **A1.2.4** shall not be used in design without further tests incorporating greater thicknesses. Calculation of design stresses using the factor of **Eq 3** shall be restricted to members not exceeding four times the volume (computed as length times depth) of the largest member tested.

A1.2.3 For single-size testing, the value of (m) is determined as follows:

$$m = C^{-1.08} \quad (\text{A1.1})$$

where:

m = shape parameter of a two-parameter Weibull distribution, and

C = COV of the data with the restriction that if $C < 0.15$ then $m = 8$.

NOTE A1.1—At $C = 0.15$, $m \sim 8$ so that $2/m = 1/4$. Specification of a minimum threshold of 0.15 on C is a default level to encourage multiple-size testing. **Eq A1.1** is an approximation that simplifies and avoids the use of the gamma function. It gives estimates of (m) accurate to 2 % for COV's in the range from 0.05 to 0.30.

A1.2.4 Minimum sampling for multiple-size testing requires a minimum of four depths, including the base depth specified in **6.5.1**, with sample sizes as specified in **A1.2.5**. The test range of volume (computed as length times depth) shall have a ratio of not less than 20 from the smallest depth to the largest piece. Span-to-depth ratios in all test series shall be the same and as selected in **6.5.1**. From **Eq 3**:

$$K_d = \left(\frac{d_1}{d}\right)^{2/m} \quad (\text{A1.2})$$

A1.2.5 Sample sizes below the base depth shall be 30 for each depth. Above the base depth the sample size, N , shall be determined by the following formula but not less than $N = 5$. Sample size for the base depth is given in **6.2**:

$$N = 50 \left(\frac{d_1}{d}\right) \quad (\text{A1.3})$$

where:

d_1 = base depth tested in **6.5.1**, and

d = any depth larger than base.

NOTE A1.2—The sample size equation is simple and judgmental. Experience on structural composite lumber has shown that test results from larger members are less variable. The expectation of lower variability for larger specimens in a weak link analysis can also be supported theoretically using a