

FINAL  
DRAFT

INTERNATIONAL  
STANDARD

ISO/FDIS  
11898-2

ISO/TC 22/SC 31

Secretariat: DIN

Voting begins on:  
2023-11-29

Voting terminates on:  
2024-01-24

---

---

## Road vehicles — Controller area network (CAN) —

### Part 2: High-speed physical medium attachment (PMA) sublayer

iTeh Standards  
(<https://standards.iteh.ai>)  
Document Preview

[ISO/FDIS 11898-2](https://standards.iteh.ai/catalog/standards/sist/1517b356-0680-45f6-a27e-619f8e26ef6e/iso-fdis-11898-2)

<https://standards.iteh.ai/catalog/standards/sist/1517b356-0680-45f6-a27e-619f8e26ef6e/iso-fdis-11898-2>

RECIPIENTS OF THIS DRAFT ARE INVITED TO SUBMIT, WITH THEIR COMMENTS, NOTIFICATION OF ANY RELEVANT PATENT RIGHTS OF WHICH THEY ARE AWARE AND TO PROVIDE SUPPORTING DOCUMENTATION.

IN ADDITION TO THEIR EVALUATION AS BEING ACCEPTABLE FOR INDUSTRIAL, TECHNOLOGICAL, COMMERCIAL AND USER PURPOSES, DRAFT INTERNATIONAL STANDARDS MAY ON OCCASION HAVE TO BE CONSIDERED IN THE LIGHT OF THEIR POTENTIAL TO BECOME STANDARDS TO WHICH REFERENCE MAY BE MADE IN NATIONAL REGULATIONS.



Reference number  
ISO/FDIS 11898-2:2023(E)

© ISO 2023

iTeh Standards  
(<https://standards.iteh.ai>)  
Document Preview

[ISO/FDIS 11898-2](https://standards.iteh.ai/catalog/standards/sist/1517b356-0680-45f6-a27e-619f8e26ef6e/iso-fdis-11898-2)

<https://standards.iteh.ai/catalog/standards/sist/1517b356-0680-45f6-a27e-619f8e26ef6e/iso-fdis-11898-2>



**COPYRIGHT PROTECTED DOCUMENT**

© ISO 2023

All rights reserved. Unless otherwise specified, or required in the context of its implementation, no part of this publication may be reproduced or utilized otherwise in any form or by any means, electronic or mechanical, including photocopying, or posting on the internet or an intranet, without prior written permission. Permission can be requested from either ISO at the address below or ISO's member body in the country of the requester.

ISO copyright office  
CP 401 • Ch. de Blandonnet 8  
CH-1214 Vernier, Geneva  
Phone: +41 22 749 01 11  
Email: [copyright@iso.org](mailto:copyright@iso.org)  
Website: [www.iso.org](http://www.iso.org)

Published in Switzerland

# Contents

Page

<b>Foreword</b> .....	<b>iv</b>
<b>Introduction</b> .....	<b>v</b>
<b>1 Scope</b> .....	<b>1</b>
<b>2 Normative references</b> .....	<b>1</b>
<b>3 Terms and definitions</b> .....	<b>1</b>
<b>4 Abbreviated terms</b> .....	<b>4</b>
<b>5 HS-PMA function</b> .....	<b>4</b>
5.1 Base requirements.....	4
5.2 HS-PMA test circuit.....	5
5.3 Static parameter.....	5
5.3.1 Maximum ratings of $V_{CAN\_H}$ , $V_{CAN\_L}$ and $V_{Diff}$ .....	5
5.3.2 Recessive output characteristics, bus biasing active.....	6
5.3.3 Recessive output characteristics, bus biasing inactive.....	6
5.3.4 Dominant output characteristics.....	7
5.3.5 Maximum driver output current.....	8
5.3.6 PMA static receiver input characteristics, bus biasing active and inactive.....	9
5.3.7 Receiver input resistance.....	9
5.3.8 Maximum leakage currents of CAN_H and CAN_L.....	10
5.4 Dynamic parameter.....	11
5.4.1 Driver symmetry.....	11
5.4.2 Optional transmit dominant timeout.....	11
5.4.3 Transmitter and receiver timing behaviour.....	11
5.5 Wake-up from low-power mode.....	15
5.5.1 Wake-up procedures.....	15
5.5.2 General requirement.....	15
5.5.3 Basic wake-up.....	15
5.5.4 Via wake-up pattern.....	16
5.5.5 Selective wake-up.....	18
5.5.6 Bus biasing procedure.....	23
<b>6 Conformance</b> .....	<b>25</b>
<b>Annex A (normative) HS-PMA with SIC mode and FAST mode</b> .....	<b>26</b>
<b>Annex B (informative) ECU and network design</b> .....	<b>55</b>
<b>Annex C (informative) PN physical layer modes</b> .....	<b>63</b>
<b>Bibliography</b> .....	<b>64</b>

## Foreword

ISO (the International Organization for Standardization) is a worldwide federation of national standards bodies (ISO member bodies). The work of preparing International Standards is normally carried out through ISO technical committees. Each member body interested in a subject for which a technical committee has been established has the right to be represented on that committee. International organizations, governmental and non-governmental, in liaison with ISO, also take part in the work. ISO collaborates closely with the International Electrotechnical Commission (IEC) on all matters of electrotechnical standardization.

The procedures used to develop this document and those intended for its further maintenance are described in the ISO/IEC Directives, Part 1. In particular, the different approval criteria needed for the different types of ISO document should be noted. This document was drafted in accordance with the editorial rules of the ISO/IEC Directives, Part 2 (see [www.iso.org/directives](http://www.iso.org/directives)).

ISO draws attention to the possibility that the implementation of this document may involve the use of (a) patent(s). ISO takes no position concerning the evidence, validity or applicability of any claimed patent rights in respect thereof. As of the date of publication of this document, ISO had not received notice of (a) patent(s) which may be required to implement this document. However, implementers are cautioned that this may not represent the latest information, which may be obtained from the patent database available at [www.iso.org/patents](http://www.iso.org/patents). ISO shall not be held responsible for identifying any or all such patent rights.

Any trade name used in this document is information given for the convenience of users and does not constitute an endorsement.

For an explanation of the voluntary nature of standards, the meaning of ISO specific terms and expressions related to conformity assessment, as well as information about ISO's adherence to the World Trade Organization (WTO) principles in the Technical Barriers to Trade (TBT), see [www.iso.org/iso/foreword.html](http://www.iso.org/iso/foreword.html).

This document was prepared by Technical Committee ISO/TC 22, *Road vehicles* Subcommittee SC 31, *Data communication*.

This third edition cancels and replaces the second edition (ISO 11898-2:2016), which has been technically revised.

The main changes are as follows:

- [Clause 5](#) is restructured, the parameters are categorized by static parameter and dynamic parameter;
- Table 13 with bit rates above 1 Mbit/s and up to 2 Mbit/s is in this edition [Table 15](#) (parameter set A). Table 14 with bit rates above 2 Mbit/s and up to 5 Mbit/s is now [Table 16](#) (parameter set B). The parameter set C (see [Table 17](#) and [Table 18](#)) in this edition is newly introduced;
- [Annex A](#) in this edition is newly introduced; it specifies HS-PMAs with the SIC mode and the FAST mode. [Annex B](#) and [Annex C](#) in this edition are Annex A and Annex B in the previous edition. The content is unchanged.

A list of all parts in the ISO 11898 series can be found on the ISO website.

Any feedback or questions on this document should be directed to the user's national standards body. A complete listing of these bodies can be found at [www.iso.org/members.html](http://www.iso.org/members.html).

## Introduction

The ISO 11898 series provides requirement specifications for the CAN data link layer and physical layer. It is intended for chip implementers, e.g. ISO 11898-1 for CAN protocol controllers and this document for CAN transceivers. Related conformance test plans are given in the ISO 16845 series. The CAN data link layer models the open system interconnect (OSI) data link layer; it is internally subdivided into logic link control (LLC) and medium access control (MAC). ISO 11898-1 also specifies the CAN physical coding sublayer (PCS) by means of the attachment unit interface (AUI). Optionally, the PCS also provides the PWM encoding to be linked to a CAN SIC XL transceiver, which provides the PWM decoding.

The open system interconnect (OSI) layers above the data link layer (e.g. the network layer) are not specified in the ISO 11898 series.

Figure 1 shows the relation between the OSI layers and the CAN sublayers.

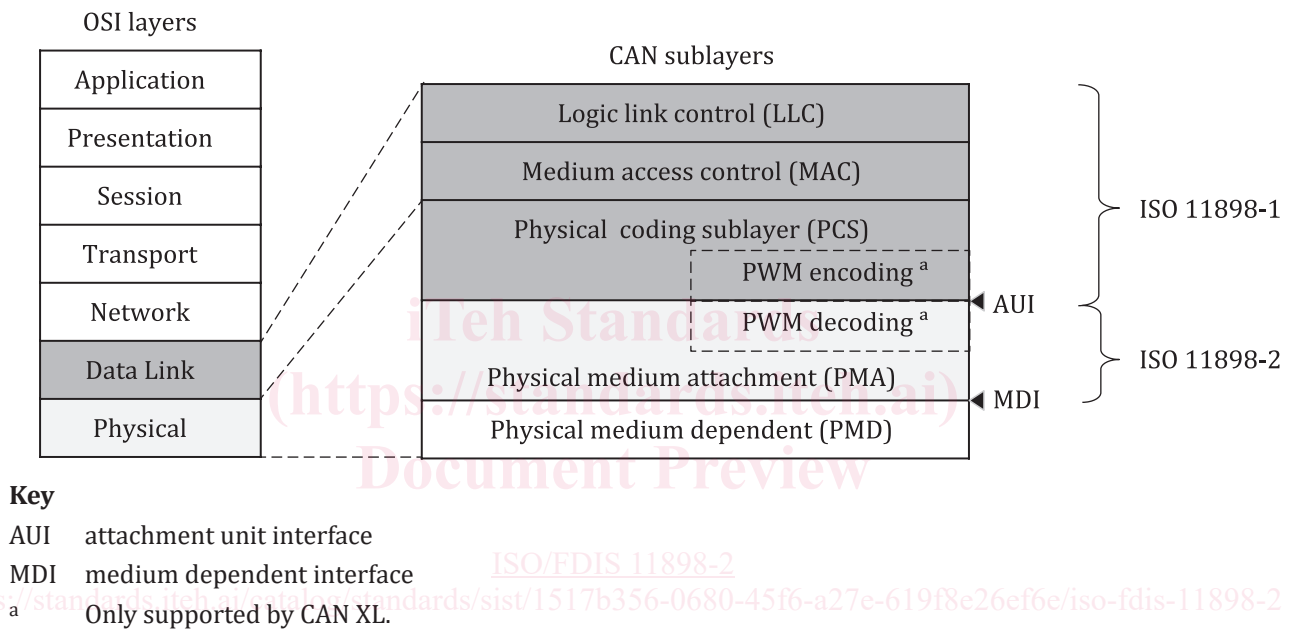

Figure 1 — CAN data link and physical sublayers relation to the OSI model



# Road vehicles — Controller area network (CAN) —

## Part 2:

# High-speed physical medium attachment (PMA) sublayer

## 1 Scope

This document specifies physical medium attachment (PMA) sublayers for the controller area network (CAN). This includes the high-speed (HS) PMA without and with low-power mode capability, without and with selective wake-up functionality. Additionally, this document specifies PMAs supporting the signal improvement capability (SIC) mode and the FAST mode in [Annex A](#). The physical medium dependent (PMD) sublayer is not in the scope of this document.

## 2 Normative references

The following documents are referred to in the text in such a way that some or all of their content constitutes requirements of this document. For dated references, only the edition cited applies. For undated references, the latest edition of the referenced document (including any amendments) applies.

ISO/IEC 7498-1, *Information technology — Open Systems Interconnection — Basic Reference Model: The Basic Model*

ISO 11898-1<sup>1)</sup>, *Road vehicles — Controller area network (CAN) — Part 1: Data link layer and physical signalling*

## 3 Terms and definitions

For the purposes of this document, the terms and definitions given in ISO/IEC 7498-1, ISO 11898-1 and the following apply.

ISO and IEC maintain terminology databases for use in standardization at the following addresses:

- ISO Online browsing platform: available at <https://www.iso.org/obp>
- IEC Electropedia: available at <https://www.electropedia.org/>

### 3.1

#### active recessive

intermediate high-speed physical medium attachment (HS-PMA) output drive with a dedicated lower than nominal impedance at transitions from dominant state or level\_0 state towards the *passive recessive* (3.14) state with a dedicated duration

### 3.2

#### attachment unit interface

##### AUI

interface between the *physical coding sublayer (PCS)* (3.15) and the *physical medium attachment (PMA)* (3.16) sublayer

### 3.3

#### bus

shared medium of any topology

1) Third edition under preparation. Stage at the time of publication: ISO/DIS 11898-1:2023.

### 3.4

#### **bus state**

state of the *medium dependent interface (MDI)* (3.11), which is dominant or recessive if the *physical medium attachment (PMA)* (3.16) sublayer is in arbitration mode, or is level\_0 or level\_1 otherwise

Note 1 to entry: The dominant state represents the logical 0 and the recessive state represents the logical 1. During simultaneous transmission of dominant and recessive bits, the resulting bus state is dominant. When no transmission is in progress, the *bus* (3.3) is idle. During idle time, it is in recessive state.

Note 2 to entry: The level\_0 state represents the logical 0, and the level\_1 state represents the logical 1.

### 3.5

#### **CAN\_H, CAN\_L**

pair of ports, where  $V_{CAN\_H} - V_{CAN\_L}$  is positive at dominant *bus state* (3.4)

### 3.6

#### **edge**

difference in *bus states* (3.4) between two consecutive time quanta

### 3.7

#### **FAST RX mode**

mode in which the *physical medium attachment (PMA)* (3.16) sublayer drives the *bus state* (3.4) recessive and the receive thresholds are adjusted to distinguish between the bus states level\_0 and level\_1

### 3.8

#### **FAST TX mode**

mode in which the *physical medium attachment (PMA)* (3.16) sublayer drives the *bus states* (3.4) level\_0 and level\_1, which are not able to overwrite each other

### 3.9

#### **legacy implementation**

HS-PMA implementation compliant with previous ISO 11898-2 editions

### 3.10

#### **low-power mode**

mode in which the transceiver is not capable of transmitting or receiving frames, except for the purposes of determining if a WUP or WUF is being received

### 3.11

#### **MDI**

medium dependent interface

electrical interface consisting of CAN\_H and CAN\_L, that defines the signal transfer between the *physical medium dependent (PMD)* sublayer and the *physical medium attachment (PMA)* (3.16) sublayer

### 3.12

#### **nominal bit time**

duration of one bit in the arbitration phase

### 3.13

#### **normal-power mode**

mode in which the transceiver is capable of transmitting and receiving

### 3.14

#### **passive recessive**

final high-speed physical medium attachment (HS-PMA) output drive with nominal impedance, also known as recessive



**3.15****physical coding sublayer**

PCS

sublayer of the open system interconnect (OSI) physical layer that performs bit encoding/decoding and synchronization

**3.16****physical medium attachment**

PMA

sublayer of the open system interconnect (OSI) physical layer that converts physical signals into logical signals and vice versa

**3.17****PWM decoding**

PWMD

*physical medium attachment (PMA)* (3.16) sublayer function decoding the pulse-width modulation (PWM) bit streams into the non-return-to-zero (NRZ) bit streams

**3.18****PWM encoding**

PWME

*physical coding sublayer (PCS)* (3.15) function encoding the non-return-to-zero (NRZ) bit streams into the pulse-width modulation (PWM) bit streams

**3.19****receiver**

node that, while the *bus* (3.3) is not idle, is neither a *transmitter* (3.23) nor is it integrating

**3.20****RXD**

port of the *attachment unit interface (AUI)* (3.2) used to transmit the actual state of the physical medium, in binary format, to the *physical coding sublayer (PCS)* (3.15)

**3.21****signal improvement capability**

SIC

capability to suppress the ringing

Note 1 to entry: It is as specified in the high-speed physical medium attachment (HS-PMA) implementation parameter set C in [Table 14](#) and [Table 17](#).

**3.22****SIC mode**

mode according to the high-speed physical medium attachment (HS-PMA) during the arbitration phase

Note 1 to entry: For PMA implementations, it is according to parameter set C or [Annex A](#).

**3.23****transmitter**

node sending CAN frames

**3.24****TXD**

port of the *attachment unit interface (AUI)* (3.2) driven by the *physical coding sublayer (PCS)* (3.15) to control how the *physical medium attachment (PMA)* (3.16) influences the actual state of the physical medium

## 4 Abbreviated terms

For the purposes of this document, the symbols and abbreviated terms given in ISO 11898-1 and the following apply. If the definition of the term in this document is different from the definition in ISO 11898-1, this definition applies.

CAN controller area network

DLC data length code

ECU electronic control unit

EMC electromagnetic compatibility

ESD electro static discharge

GND ground

HS-PMA high-speed PMA

NRZ non-return-to-zero

OSI open layer system

PMD physical medium dependent

PN partial networking

PWM pulse width modulation

RF radio frequency

WUF wake-up frame

WUP wake-up pattern

iTeh Standards  
(<https://standards.iteh.ai>)  
Document Preview

[ISO/FDIS 11898-2](https://standards.iteh.ai/catalog/standards/sist/1517b356-0680-45f6-a27e-619f8e26ef6e/iso-fdis-11898-2)

<https://standards.iteh.ai/catalog/standards/sist/1517b356-0680-45f6-a27e-619f8e26ef6e/iso-fdis-11898-2>

## 5 HS-PMA function

### 5.1 Base requirements

The HS-PMA comprises one transmitter and one receiving entity. It shall be able to bias the connected physical medium, an electric two-wire cable, relative to a common ground. The transmitter entity shall drive a differential voltage between the CAN\_H and CAN\_L signals to signal a logical 0 (dominant) or shall not drive a differential voltage to signal a logical 1 (recessive) to be received by other nodes connected to the very same medium. These two signals are the interface to the PMD sublayer.

The HS-PMA shall provide an AUI to the physical coding sublayer as specified in ISO 11898-1. It comprises the TXD and RXD signals as well as the GND signal. The TXD signal receives from the physical coding sublayer the bit stream to be transmitted on the MDI. The RXD signal transmits to the physical coding sublayer the bit stream received from the MDI.

Implementations that comprise one or more HS-PMAs shall at least support the normal-power mode of operation. A low-power mode may be implemented.

Some of the items specified in the following depend on the operation mode of the (part of the) implementation, in which the HS-PMA is included.

[Table 1](#) shows the possible combinations of HS-PMA operating modes and expected behaviour.

Table 1 — HS-PMA operating modes and expected behaviour

Operating mode	Bus-biasing behaviour	Transmitter behaviour
Normal-power mode	Bus biasing active	Dominant or recessive <sup>a</sup>
Low-power mode	Bus biasing active or inactive	Recessive
<sup>a</sup> Depends on input conditions as described in this document.		

Parameters given in [Clause 5](#) shall be fulfilled throughout the operating temperature range and supply voltage range (if not explicitly specified for unpowered) as specified individually for every HS-PMA implementation.

## 5.2 HS-PMA test circuit

The outputs of the HS-PMA implementation to the CAN signals are called CAN\_H and CAN\_L, TXD is the transmit data input and RXD is the receive data output. [Figure 2](#) shows the external circuit used to measure the specified voltage and current parameters.  $R_L$  represents the effective resistive load (bus load) for an HS-PMA implementation, when used in a network, and  $C_1$  represents an optional split-termination capacitor. The values of  $R_L$  and  $C_1$  vary for different parameters that the HS-PMA implementation needs to meet and are given as condition in the tables of related parameters.

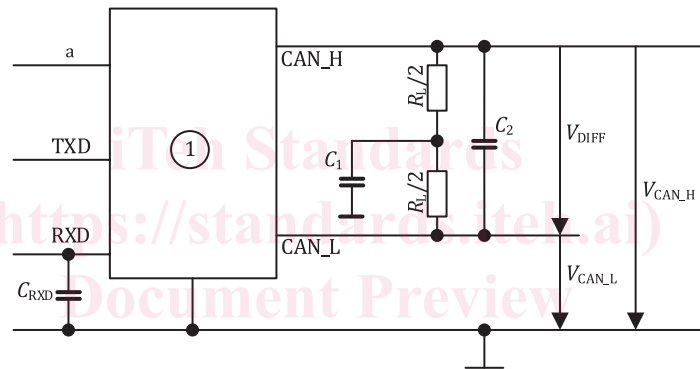

### Key

- 1 PMA implementation
- $V_{DIFF}$  differential voltage between CAN\_H and CAN\_L wires
- $V_{CAN\_H}$  single-ended voltage on CAN\_H wire
- $V_{CAN\_L}$  single-ended voltage on CAN\_L wire
- $C_{RXD}$  capacitive load on RXD
- $C_1$  optional split-termination capacitor
- $C_2$  differential capacitive load
- $R_L$  differential load resistance
- <sup>a</sup> Power supply for the PMA implementation.

Figure 2 — HS-PMA test circuit

## 5.3 Static parameter

### 5.3.1 Maximum ratings of $V_{CAN\_H}$ , $V_{CAN\_L}$ and $V_{DIFF}$

[Table 2](#) specifies upper and lower limit static voltages, which can be applied to CAN\_H and CAN\_L without causing damage, while  $V_{DIFF}$  stays within in its own maximum rating range.

**Table 2 — HS-PMA maximum ratings of  $V_{CAN\_H}$ ,  $V_{CAN\_L}$  and  $V_{Diff}$**

Parameter description	Notation	Value	
		Min. [V]	Max. [V]
Maximum rating	$V_{Diff}^a$	-5,0	+10,0
General maximum rating	$V_{CAN\_H}$ , $V_{CAN\_L}$	-27,0	+40,0
Optional: Extended maximum rating	$V_{CAN\_H}$ , $V_{CAN\_L}$	-58,0	+58,0
<p><sup>a</sup> This is required regardless whether general or extended maximum rating for <math>V_{CAN\_H}</math> and <math>V_{CAN\_L}</math> is fulfilled.</p> <p>Applies to HS-PMA implementation powered and unpowered conditions. Applies to transmit data input de-asserted and transmit data input (TXD) becomes asserted while CAN_H or/and CAN_L connected to a fixed voltage.</p> <p>The maximum rating for <math>V_{Diff}</math> excludes that all combinations of <math>V_{CAN\_H}</math> and <math>V_{CAN\_L}</math> are compliant to this document. <math>V_{Diff} = V_{CAN\_H} - V_{CAN\_L}</math>, see <a href="#">Figure 2</a>.</p>			

**5.3.2 Recessive output characteristics, bus biasing active**

[Table 3](#) specifies the recessive output characteristics when bus biasing is active.

**Table 3 — HS-PMA recessive output characteristics, bus biasing active**

Parameter	Notation	Value		
		Min. [V]	Nom. [V]	Max. [V]
Single-ended output voltage on CAN_H (based on supply reference voltage) <sup>a</sup>	$V_{CAN\_H}$	+2,0	+2,5	+3,0
Single-ended output voltage on CAN_H <sup>b</sup>	$V_{CAN\_H\_rec}$	+2,137	+2,5	+2,887
Single-ended output voltage on CAN_L (based on based on supply reference voltage) <sup>a</sup>	$V_{CAN\_L}$	+2,0	+2,5	+3,0
Single-ended output voltage on CAN_L <sup>b</sup>	$V_{CAN\_L\_rec}$	+2,137	+2,5	+2,887
Differential output voltage	$V_{Diff}$	-0,5	0	+0,05
<p>NOTE The requirements in this table apply concurrently. Therefore, not all combinations of <math>V_{CAN\_H}</math> and <math>V_{CAN\_L}</math> are compliant with the defined differential output voltage.</p> <p><sup>a</sup> Measurement setup according to <a href="#">Figure 2</a> (including implementations with selective wake-up function):  <math>R_L &gt; 10^{10} \Omega</math> (not present)  <math>C_1 = 0</math> pF (not present)  <math>C_2 = 0</math> pF (not present)  <math>C_{RXD} = 0</math> pF (not present)</p> <p><sup>b</sup> Measurement setup according to <a href="#">Figure 2</a>:  <math>R_L = 60 \Omega</math> (tolerance <math>\leq \pm 1 \%</math>)  <math>C_1 = 0</math> pF (not present)  <math>C_2 = 0</math> pF (not present)  <math>C_{RXD} = 0</math> pF (not present)</p>				

**5.3.3 Recessive output characteristics, bus biasing inactive**

[Table 4](#) specifies the recessive output characteristics when bus biasing is inactive.

**Table 4 — HS-PMA recessive output characteristics, bus biasing inactive**

Parameter	Notation	Value <sup>a</sup>		
		Min. [V]	Nom. [V]	Max. [V]
Single-ended output voltage on CAN_H	$V_{CAN\_H}$	-0,1	0	+0,1
Single-ended output voltage on CAN_L	$V_{CAN\_L}$	-0,1	0	+0,1
Differential output voltage	$V_{Diff}$	-0,2	0	+0,2
NOTE See 5.5.6 to determine when bias is inactive.				
<sup>a</sup> Measurement setup according to Figure 2:				
$R_L > 10^{10} \Omega$ (not present)				
$C_1 = 0$ pF (not present)				
$C_2 = 0$ pF (not present)				
$C_{RXD} = 0$ pF (not present)				

### 5.3.4 Dominant output characteristics

Table 5 specifies the output characteristics during dominant state. Figure 3 illustrates the voltage range for the dominant state.

**Table 5 — HS-PMA dominant output characteristics**

Parameter	Notation	Value <sup>a</sup>			Condition <sup>b</sup>
		Min. [V]	Nom. [V]	Max. [V]	
Single-ended voltage on CAN_H	$V_{CAN\_H}$	+2,75	+3,5	+4,5	$R_L = 50 \Omega$ to $65 \Omega$
Single-ended voltage on CAN_L	$V_{CAN\_L}$	+0,5	+1,5	+2,25	$R_L = 50 \Omega$ to $65 \Omega$
Differential voltage on normal bus load	$V_{Diff}$	+1,5	+2,0	+3,0	$R_L = 50 \Omega$ to $65 \Omega$
Differential voltage on effective resistance during arbitration	$V_{Diff}$	+1,5	Not defined	+5,0	$R_L = 2\ 240 \Omega$ (See NOTE)
Optional: Differential voltage on extended bus load range	$V_{Diff}$	+1,4	+2,0	+3,3	$R_L = 45 \Omega$ to $70 \Omega$
NOTE Assuming a maximum $R_L$ of $70 \Omega$ , this scenario covers a 32-node network ( $2\ 240 \Omega / 70 \Omega = 32$ ), $2\ 240 \Omega$ is emulating a situation with up to 32 nodes transmitting dominant value simultaneously. In such case, the effective load resistance for single nodes decreases (a node does drive only a part of the nominal bus load).					
<sup>a</sup> Requirements given in this table apply concurrently. Therefore, not all combinations of $V_{CAN\_H}$ and $V_{CAN\_L}$ are compliant with the defined differential voltage (see Figure 3).					
<sup>b</sup> Measurement setup according to Figure 2:					
$C_1 = 0$ pF (not present)					
$C_2 = 0$ pF (not present)					
$C_{RXD} = 0$ pF (not present)					

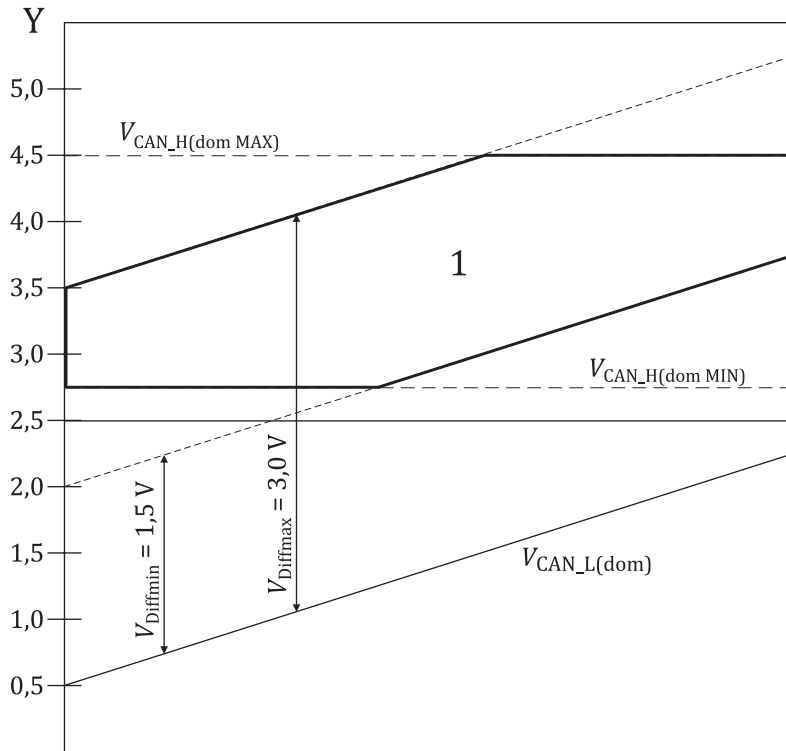

**Key**

- Y  $V_{CAN\_H}$  and  $V_{CAN\_L}$
- 1 range of  $V_{CAN\_H(dom)}$
- $V_{Diff}$  differential voltage between CAN\_H and CAN\_L wires
- $V_{CAN\_H}$  single-ended voltage on CAN\_H wire
- $V_{CAN\_L}$  single-ended voltage on CAN\_L wire

**Figure 3 — Voltage range of  $V_{CAN\_H}$  during dominant state of CAN node, when  $V_{CAN\_L}$  varies from minimum to maximum voltage level (50-Ω to 65-Ω bus-load condition)**

**5.3.5 Maximum driver output current**

Table 6 specifies the maximum HS-PMA driver output current.

**Table 6 — Maximum HS-PMA driver output current**

Parameter	Notation	Value <sup>a</sup>		Condition
		Min. [mA]	Max. [mA]	
Absolute current on CAN_H	$I_{CAN\_H}$	not specified	115	$-3\text{ V} \leq V_{CAN\_H} \leq +18\text{ V}$
Absolute current on CAN_L	$I_{CAN\_L}$	not specified	115	$-3\text{ V} \leq V_{CAN\_L} \leq +18\text{ V}$

NOTE It is expected that the implementation does not stop driving its output dominant when the differential voltage between CAN\_H and CAN\_L is outside the limits given in the condition column. The minimum output current is implicitly specified in Table 5 and thus can be expected to be above 30 mA.

<sup>a</sup> Measurement setup according to Figure 2:  
 $R_L > 10^{10}\ \Omega$  (not present)  
 $C_1 = 0\text{ pF}$  (not present)  
 $C_2 = 0\text{ pF}$  (not present)  
 $C_{RXD} = 0\text{ pF}$  (not present)