



Designation: G109 – 07 (Reapproved 2013)

# Standard Test Method for Determining Effects of Chemical Admixtures on Corrosion of Embedded Steel Reinforcement in Concrete Exposed to Chloride Environments<sup>1</sup>

This standard is issued under the fixed designation G109; the number immediately following the designation indicates the year of original adoption or, in the case of revision, the year of last revision. A number in parentheses indicates the year of last reapproval. A superscript epsilon ( $\epsilon$ ) indicates an editorial change since the last revision or reapproval.

## 1. Scope

1.1 This test method covers a procedure for determining the effects of chemical admixtures on the corrosion of metals in concrete. This test method can be used to evaluate materials intended to inhibit chloride-induced corrosion of steel in concrete. It can also be used to evaluate the corrosivity of admixtures in a chloride environment.

1.2 The values stated in SI units are to be regarded as standard. The values given in parentheses are for information only.

1.3 *This standard does not purport to address all of the safety concerns, if any, associated with its use. It is the responsibility of the user of this standard to establish appropriate safety and health practices and determine the applicability of regulatory limitations prior to use.*

## 2. Referenced Documents

### 2.1 ASTM Standards:<sup>2</sup>

- A615/A615M Specification for Deformed and Plain Carbon-Steel Bars for Concrete Reinforcement
- C33 Specification for Concrete Aggregates
- C143/C143M Test Method for Slump of Hydraulic-Cement Concrete
- C150 Specification for Portland Cement
- C173/C173M Test Method for Air Content of Freshly Mixed Concrete by the Volumetric Method
- C192/C192M Practice for Making and Curing Concrete Test Specimens in the Laboratory
- C231 Test Method for Air Content of Freshly Mixed Concrete by the Pressure Method

<sup>1</sup> This test method is under the jurisdiction of ASTM Committee G01 on Corrosion of Metals and is the direct responsibility of Subcommittee G01.14 on Corrosion of Metals in Construction Materials.

Current edition approved May 1, 2013. Published July 2013. Originally approved in 1992. Last previous edition approved in 2007 as G109–07. DOI: 10.1520/G0109-07R13.

<sup>2</sup> For referenced ASTM standards, visit the ASTM website, www.astm.org, or contact ASTM Customer Service at service@astm.org. For *Annual Book of ASTM Standards* volume information, refer to the standard's Document Summary page on the ASTM website.

- C511 Specification for Mixing Rooms, Moist Cabinets, Moist Rooms, and Water Storage Tanks Used in the Testing of Hydraulic Cements and Concretes
  - C876 Test Method for Corrosion Potentials of Uncoated Reinforcing Steel in Concrete
  - C881/C881M Specification for Epoxy-Resin-Base Bonding Systems for Concrete
  - C1152/C1152M Test Method for Acid-Soluble Chloride in Mortar and Concrete
  - D448 Classification for Sizes of Aggregate for Road and Bridge Construction
  - D632 Specification for Sodium Chloride
  - E177 Practice for Use of the Terms Precision and Bias in ASTM Test Methods
  - E691 Practice for Conducting an Interlaboratory Study to Determine the Precision of a Test Method
  - G3 Practice for Conventions Applicable to Electrochemical Measurements in Corrosion Testing
  - G15 Terminology Relating to Corrosion and Corrosion Testing (Withdrawn 2010)<sup>3</sup>
  - G33 Practice for Recording Data from Atmospheric Corrosion Tests of Metallic-Coated Steel Specimens
  - G46 Guide for Examination and Evaluation of Pitting Corrosion
- 2.2 NACE Standards:<sup>4</sup>
- SSPC-SP 5/NACE No. 1 White Metal Blast Cleaning

## 3. Significance and Use

3.1 This test method provides a reliable means for predicting the inhibiting or corrosive properties of admixtures to be used in concrete.

3.2 This test method is useful for development studies of corrosion inhibitors to be used in concrete.

3.3 This test method has been used elsewhere with good agreement between corrosion as measured by this test method

<sup>3</sup> The last approved version of this historical standard is referenced on www.astm.org.

<sup>4</sup> Available from The Society for Protective Coatings (SSPC), 40 24th St., 6th Floor, Pittsburgh, PA 15222-4656.

and corrosion damage on the embedded steel (1-4).<sup>5</sup> This test method might not properly rank the performance of different corrosion inhibitors, especially at concrete covers over the steel less than 40 mm (1.5 in.) or water-to-cement ratios above 0.45. The concrete mixture proportions and cover over the steel are chosen to accelerate chloride ingress. Some inhibitors might have an effect on this process, which could lead to results that would differ from what would be expected in actual use (5).

#### 4. Apparatus

4.1 The apparatus required for the evaluation of corrosion inhibitors includes a high impedance voltmeter (at least one Mohm) capable of measuring to 0.01 mV, a 100 Ω (±5 %) resistor.

#### 5. Reagents and Materials

5.1 *Cement*, that conforms to Type I or Type II of Specification C150. Coarse aggregate shall conform to Specification C33 and Classification D448, with nominal maximum size between 9.5 and 19 mm (3/8 and 3/4 in.).

NOTE 1—Preferred maximum size aggregate is 12.5 mm (0.5 in.).

5.2 *Steel Reinforcement Bars*, deformed, meeting the requirement of Specification A615/A615M; with a diameter between 10 mm (0.4 in.) and 16 mm (0.6 in.), and a length of 360 mm (14 in.), drilled and tapped at one end to be fitted with coarse-thread stainless steel and nuts, as described in 5.3 and 5.4. These bars shall be used to manufacture the test specimens, as described in Section 6.

NOTE 2—Interlaboratory test program and statistical data in Section 11 are based upon 13-mm (0.5-in.) steel bars, 12.5-mm maximum size aggregate, and 19-mm (0.75-in.) and 25-mm (1 in.) cover.

5.3 *316 Stainless Steel Screws*, with diameter smaller than bar diameter (coarse thread < 5 mm (0.2 in.)), 25 to 35-mm (1 to 1.5-in.) long (one per bar).

5.4 *316 Stainless Steel Nuts*, two per bar to fit stainless steel screws, as described in 5.3.

5.5 *Two-part Waterproof Epoxy*<sup>6,7</sup>—This epoxy shall meet the chemical resistance requirements of a Type IV, Grade 3, Class E of Specification C881/C881M.

5.6 *Sulfuric Acid*, 10 % by mass, for pickling (optional).

5.7 *Electroplater's Tape*.<sup>7,8</sup>

5.8 *Neoprene Tubing*, with 3-mm (1/8-in.) wall thickness and the same ID as the diameter of the bar used.

5.9 *Sodium Chloride*, complying with Specification D632.

5.10 *Salt Solution*, prepared by dissolving 3 parts of sodium chloride (as described in 5.9) in 97 parts of water mass.

<sup>5</sup> The boldface numbers in parentheses refer to a list of references at the end of this standard.

<sup>6</sup> The sole source of supply of the apparatus known to the committee at this time is PC-Epoxy, made by Protective Coating Co., Allentown, PA.

<sup>7</sup> If you are aware of alternative suppliers, please provide this information to ASTM International Headquarters. Your comments will receive careful consideration at a meeting of the responsible technical committee,<sup>1</sup> which you may attend.

<sup>8</sup> The sole source of supply of the apparatus known to the committee at this time is Minnesota Mining and Manufacturing Company (3M), 1999 Mt. Read Boulevard, Rochester, NY 14615.

5.11 *Epoxy Sealer*, for application to the concrete specimens after manufacture. This sealer shall be of Type III, Grade 1, Class C in accordance with Specification C881/C881M.<sup>7,9</sup>

5.12 *Plastic Dams*, 75-mm (3-in.) wide and 150-mm (6-in.) long with a minimum height of 75 mm (3 in.) for placement on the test specimens. The wall thickness shall be ±1 mm (1/8 ± 1/32 in.).

5.13 *Silicone Caulk*, for sealing the outside of the plastic dam to the top of the concrete specimen.<sup>7,10</sup>

5.14 *Reference Electrode*, such as a saturated calomel or silver/silver chloride electrode for measuring the corrosion potential of the bars, as defined in Terminology G15.

5.15 *Hexane*.

#### 6. Preparation of Test Specimens

6.1 Power wire brush or sand blast the bars to near white metal (see SSPC-SP 5/NACE No. 1), clean by soaking in hexane, and allow to air dry.

NOTE 3—Pickling the bars with 10 % sulfuric acid for 10 to 15 min and rinsing with potable water prior to wire brushing is recommended when the bars have an excessive amount of rust.

6.2 Use the same method to clean all bars in the test program.

6.3 Drill and tap one end of each bar, attach a stainless steel screw and two nuts, as described in 5.3 and 5.4, and tape each end of the bar with electroplater's tape so that a 200-mm (8-in.) portion in the middle of the bar is bare. Place a 90-mm (3.5 in.) length of neoprene tubing, as described in 5.8, over the electroplater's tape at each end of the bar, and fill the length of tubing protruding from the bar ends with the two-part epoxy, as described in 5.5.

6.4 Specimen size is 280 × 150 × 115 mm (11 × 6 × 4.5 in.). Place two bars, as described in 5.2, 25 mm (1 in.) from the bottom, and one bar at the top such that the distance from its top to the top surface of the specimen is twice the maximum aggregate size, as shown in Fig. 1.

NOTE 4—For example, for a 12.5-mm (0.5 in.) aggregate, place the top bar 25 mm (1 in.) from the surface. For a 9.5-mm (0.375-in.) aggregate, place the bar 19 mm (0.75 in.) from the top surface.

6.5 Place the bars in the molds so that 40 mm (approximately 1.5 in.) of the bars are protected within each exit end from the concrete (minimizes edge effects). This will expose 200 mm (8 in.) of steel. Place the bars with the longitudinal ribs so that they are nearer the side of the beam, that is, both ridges are equidistant from the top or bottom of the specimen.

6.6 Make the concrete specimens (controls and those with admixtures to be tested) in accordance with Practice C192/C192M, using the same source of materials. Determine the air content, using either Test Method C231 or C173/C173M. The water-to-cement ratio (w/c) shall not exceed 0.5. The minimum

<sup>9</sup> The sole source of supply of the apparatus known to the committee at this time is Epoxy Concrete Sealer # 12560, made by Devcon.

<sup>10</sup> The sole source of supply of the apparatus known to the committee at this time is 3M Marine Adhesive 5200.

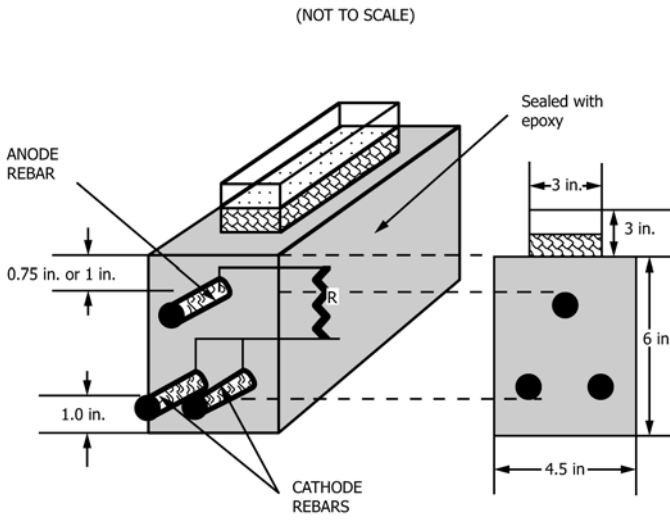

NOTE 1—All measurements in inches (25.4 mm = 1 in.).

FIG. 1 Concrete Beam

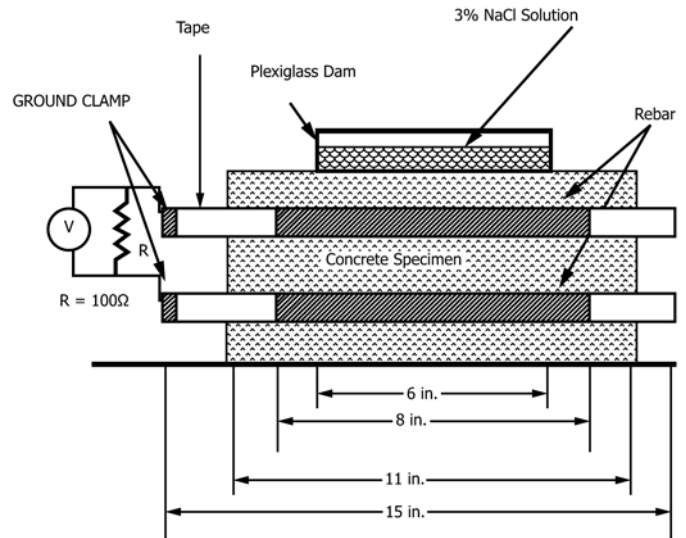

NOTE 1—All measurements in inches (not to scale) (25.4 mm = 1 in.).

FIG. 2 Concrete Beam (Side View)

slump is 50 mm (2 in.) (See Test Method C143/C143M). Place and consolidate the concrete in the molds containing the bars in accordance with Practice C192/C192M.

NOTE 5—The concrete parameters used in the interlaboratory test were as follows: cement content of  $355 \pm 3 \text{ kg/m}^3$  ( $600 \pm 5 \text{ lb/yd}^3$ ),  $0.50 \pm 0.01 \text{ w/c}$  (ssd aggregates), and  $6 \pm 1 \%$  air.

6.7 Add the admixture to be tested at the manufacturer's recommended dosages. A water reducer is allowed, if needed, to achieve the desired slump. Record the admixtures used. Except for the test admixtures, use the same admixtures in all mixtures.

6.8 A minimum of three replicates shall be made. Make the same number of replicates per admixture tested and control (see Note 6). An addition cylinder  $100 \times 200 \text{ mm}$  ( $4 \times 8 \text{ in.}$ ) in diameter shall be produced for background chloride analysis.

NOTE 6—A larger number of replicates is preferred.

6.9 Apply a wood float finish after consolidation. After removal from the forms, cure the specimens for 28 days in a moist room in accordance with Test Method C192/C192M and Specification C511.

6.10 Upon removal from the moist room, hand wire brush the specimens on the concrete top surface (wood floated surface). Allow the specimens to dry for two weeks in a 50 % relative humidity (RH) environment before sealing the four vertical sides with an epoxy sealer, as described in 5.11, in accordance with the manufacturer's recommendation. Place a plastic dam with dimensions, as described in 5.12, on the specimen, as shown in Fig. 1, and about 13 mm (0.5 in.) from each side so that it does not extend over the taped sections of the bars (see Fig. 2). Use a silicone caulk to seal the dam from the outside, and apply epoxy sealer to the top surface outside of the dam.

NOTE 7—Allowing the specimens to dry before applying the concrete epoxy will make the initial exposure to chloride more severe, and more closely follow the interlaboratory test program conditions.

6.11 Attach wires and resistors.

## 7. Procedure

7.1 Support each test specimen on two nonelectrically conducting supports at least 13-mm (0.5-in.) thick, thus allowing air flow under most of the specimen. Start the test one month after the samples are removed from the 100 % RH atmosphere (moist room). Pond the specimens for two weeks at  $23 \pm 3^\circ\text{C}$  ( $73 \pm 5^\circ\text{F}$ ) with the salt solution, as described in 5.10. The volume of this solution is approximately 400 mL at a depth of 40 mm (1.5 in.). Use a plastic loose fitting cover to minimize evaporation. Maintain a relative humidity around the specimens of  $50 \pm 5 \%$ . After two weeks, vacuum off the solution and allow the samples to dry for two weeks. Repeat this cycle.

7.2 Measure the voltage across the resistor at the beginning of the second week of ponding using the voltmeter defined in 4.1. Calculate the current,  $I_j$ , from the measured voltage across the  $100 \Omega$  resistor,  $V_j$ , measured in volts (see Note 8) as:

$$I_j = V_j / 100$$

NOTE 8—With the common terminal on the bottom bar, negative voltages correspond to positive galvanic current (that is, the top bar is the anode).

7.3 At the same time, measure the corrosion potential of the bars against a reference electrode that is placed in the dam containing the salt solution (see Practice G3 and Test Method C876). Connect the voltmeter between the reference electrode (ground or common terminal) and the bars.

## 8. Period of Testing

8.1 Monitor the current as a function of time once every four weeks, as described in 7.2, until the average integrated macrocell current of the control specimens is 150 C or greater, as determined in 10.1.8, and at least half the samples show integrated macrocell currents equal to or greater than 150 C (see Note 9).

NOTE 9—The value of 150 C is consistent with a macrocell current of  $10 \mu\text{A}$  over six months. The value of  $10 \mu\text{A}$  was measured by all