



Designation: G146 – 01 (Reapproved 2013)

Standard Practice for Evaluation of Disbonding of Bimetallic Stainless Alloy/Steel Plate for Use in High-Pressure, High-Temperature Refinery Hydrogen Service¹

This standard is issued under the fixed designation G146; the number immediately following the designation indicates the year of original adoption or, in the case of revision, the year of last revision. A number in parentheses indicates the year of last reapproval. A superscript epsilon (ϵ) indicates an editorial change since the last revision or reapproval.

1. Scope

1.1 This practice covers a procedure for the evaluation of disbonding of bimetallic stainless alloy/steel plate for use in refinery high-pressure/high-temperature (HP/HT) gaseous hydrogen service. It includes procedures to (1) produce suitable laboratory test specimens, (2) obtain hydrogen charging conditions in the laboratory that are similar to those found in refinery HP/HT hydrogen gas service for evaluation of bimetallic specimens exposed to these environments, and (3) perform analysis of the test data. The purpose of this practice is to allow for comparison of data among test laboratories on the resistance of bimetallic stainless alloy/steels to hydrogen-induced disbonding (HID).

1.2 This practice applies primarily to bimetallic products fabricated by weld overlay of stainless alloy onto a steel substrate. Most of the information developed using this practice has been obtained for such materials. The procedures described herein, may also be appropriate for evaluation of hot roll bonded, explosive bonded, or other suitable processes for applying stainless alloys on steel substrates. However, due to the broad range of possible materials, test conditions, and variations in test procedures, it is up to the user of this practice to determine the suitability and applicability of these procedures for evaluation of such materials.

1.3 This practice is intended to be applicable for evaluation of materials for service conditions involving severe hydrogen charging which may produce HID as shown in Fig. 1 for stainless steel weld overlay on steel equipment (see Refs 1 and 2 in Appendix X1). However, it should be noted that this practice may not be appropriate for forms of bimetallic construction or service conditions which have not been observed to cause HID in service.

1.4 Additional information regarding the evaluation of bimetallic stainless alloy/steel plate for HID, test methodologies,

and the effects of test conditions, materials, and welding variables, and inspection techniques is given in Appendix X1.

1.5 The values stated in SI units are to be regarded as standard. No other units of measurement are included in this standard.

1.6 *This standard does not purport to address all of the safety concerns, if any, associated with its use. It is the responsibility of the user of this standard to establish appropriate safety and health practices and determine the applicability of regulatory limitations prior to use.* See Section 6 for additional safety information.

2. Referenced Documents

2.1 *ASTM Standards*:²

G111 Guide for Corrosion Tests in High Temperature or High Pressure Environment, or Both
E3 Guide for Preparation of Metallographic Specimens

2.2 *ASME Standard*:

Boiler and Pressure Vessel Code Section V, Article 5, Technique Two³

3. Terminology

3.1 *Definitions*:

3.1.1 *HID*—a delamination of a stainless alloy surface layer from its steel substrate produced by exposure of the material to a hydrogen environment.

3.1.1.1 *Discussion*—This phenomenon can occur in internally stainless alloy lined steel equipment by the accumulation of molecular hydrogen in the region of the metallurgical bond at the interface between the steel and stainless alloy surface layer produced by exposure to service conditions involving HP/HT hydrogen in the refinery hydroprocessing.

¹ This practice is under the jurisdiction of ASTM Committee G01 on Corrosion of Metals and is the direct responsibility of Subcommittee G01.05 on Laboratory Corrosion Tests.

Current edition approved May 1, 2013. Published July 2013. Originally approved in 1996. Last previous edition in 2007 as G146 – 01 (2007). DOI: 10.1520/G0146-01R13.

² For referenced ASTM standards, visit the ASTM website, www.astm.org, or contact ASTM Customer Service at service@astm.org. For *Annual Book of ASTM Standards* volume information, refer to the standard's Document Summary page on the ASTM website.

³ Available from American Society of Mechanical Engineers (ASME), ASME International Headquarters, Three Park Ave., New York, NY 10016-5990, <http://www.asme.org>.

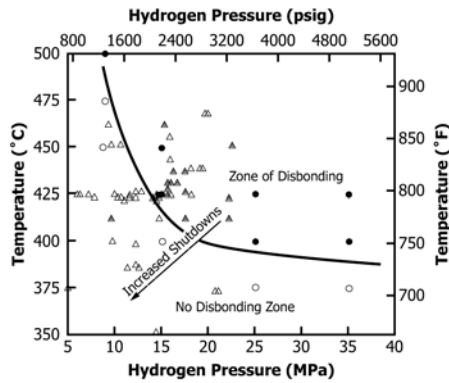

NOTE 1—Open symbols—no disbonding reported. Filled symbols—disbonding reported.

FIG. 1 Conditions of Hydrogen Partial Pressure and Temperature with Demonstrated Susceptibility to Hydrogen Disbonding in Refinery High-Pressure Hydrogen Service

4. Summary of Practice

4.1 Stainless alloy/steel specimens are exposed to a gaseous hydrogen containing environment at HP/HT conditions for sufficient time to produce hydrogen charging in the material. Following exposure, the specimens are cooled to ambient temperature at a controlled rate. The specimens are then held at room temperature for a designated period to allow for the development of HID between the stainless alloy surface layer and the steel. Following the hold period, the specimens are evaluated for HID at this interface using straight beam ultrasonic methods with metallographic examination to confirm any HID found. The size and distribution of the disbonded region(s) are then characterized by this practice. Single or multiple hydrogen exposure/cooling cycles can be conducted and varying exposure conditions and cooling rates can be incorporated into this evaluation to provide assessment of the disbonding characteristics of materials and service condition used for refinery process equipment containing HP/HT hydrogen containing environments.

5. Significance and Use

5.1 This practice provides an indication of the resistance or susceptibility, or both, to HID of a metallurgically bonded stainless alloy surface layer on a steel substrate due to exposure to hydrogen-containing gaseous environments under HP/HT conditions. This practice is applicable over a broad range of pressures, temperatures, cooling rates, and gaseous hydrogen environments where HID could be a significant problem. These procedures can be used to assess the effects of material composition, processing methods, fabrication techniques, and heat treatment as well as the effects of hydrogen partial pressure, service temperature, and cooling rate. The HID produced by these procedures may not correlate directly with service experience for particular applications. Additionally, this practice does not address the evaluation of high-temperature hydrogen attack in the steel substrate. Typically, longer exposure times at the test conditions must be utilized to allow for the resistance to decarburization, internal blistering or cracking, or both, to be evaluated.

6. Apparatus

6.1 Because this practice is intended to be conducted at high pressures and high temperatures, the apparatus must be constructed to safely contain the test environment while being resistant to the cumulative embrittling effects of hydrogen. Secondly, the test apparatus must be capable of allowing (1) introduction of the test gas, (2) removal of air from the test cell, (3) uniform heating of the test specimens, and (4) cooling of the specimens at controlled rates.

6.2 There are many types of test cell configurations which can be used to conduct evaluations of HID. This practice does not recommend or endorse any particular test cell design. Fig. 2 shows a schematic representation of a typical test cell designed to conduct HID tests in HP/HT gaseous hydrogen environments. Other designs may also provide acceptable performance. However, the typical components should include the following:

6.2.1 *Metal Test Cell*—The test cell should be constructed from materials which have been proven to have high resistance to hydrogen embrittlement and high-temperature hydrogen attack under the anticipated test conditions. Materials with low resistance to these phenomena should be avoided. Typical test cells for high-pressure hydrogen testing are constructed from stainless steel (UNS S31600 or S34700) or nickel alloys (UNS N10276 or N06625) in the solution annealed condition. Steel vessels with stainless alloy exposed surfaces may also be suitable.

6.2.2 *Closure and Seal*—To facilitate operation of the test cell, the closure should provide for rapid opening and closing of the test cell while retaining reliable sealing capabilities for

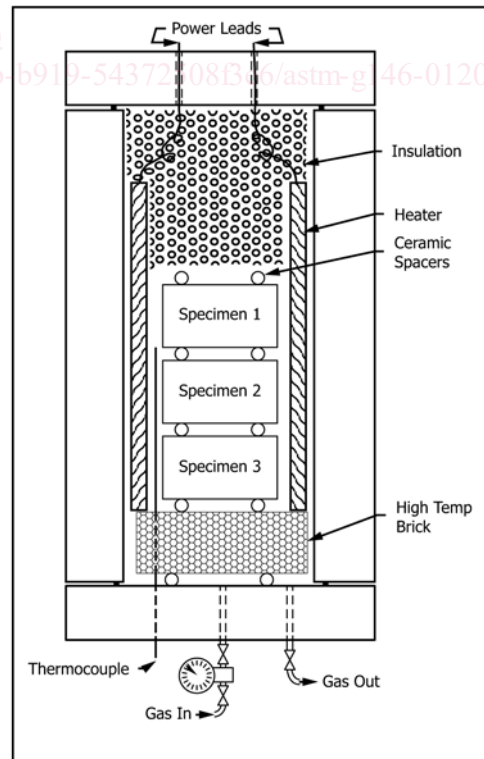

FIG. 2 Typical Test Cell

hydrogen. This can include either metallic or nonmetallic materials with high resistance to thermal degradation and hydrogen attack.

6.2.3 *Gas Port(s)*—The gas port should be designed to promote flow and circulation of the gaseous test environments, inert gas purging, and evacuation as required to produce the intended test environment. Usually two ports are used so that separate flow-through capabilities are attained to facilitate these functions.

6.2.4 *Electrical Feed-Throughs*—High-temperature conditions are required in this practice. It is usually advantageous to utilize an internal heater to heat just the test specimens and the gaseous environment in the immediate vicinity of the specimen. Therefore, feed-throughs are usually needed to make electrical contact with an internal resistance or induction heater. These feed-throughs must also provide (1) electrical isolation from the test cell and internal fixtures and (2) maintain a seal to prevent leakage of the test environment. If external heaters are used, no electric feed-throughs are required.

6.2.5 *Electric Resistance or Induction Heater(s)*—Either internal or external heaters can be used to obtain elevated temperature. For lower temperatures (<300°C), external heating of the test cell is typically more convenient but may limit cooling rates since they heat the entire vessel. For high temperatures (>300°C), an internal heater is commonly used to heat only the test specimen and the gaseous environment in the vicinity of the test specimens to limit power requirements and problems with high-temperature sealing and pressure containment.

7. Reagents

7.1 *Purity of Reagents*—Low oxygen gases (<1 ppm) shall be used in all tests.

8. Test Conditions

8.1 The test environment is based on attaining conditions of high-pressure hydrogen gas. The test temperature and hydrogen gas pressure are selected to simulate those conditions found in refinery hydrogen-containing environments. These typically range from 14 to 20 MPa hydrogen gas pressure and temperature from 300 to 500°C depending on actual refinery service conditions under consideration, but may be selected over the range of conditions in Fig. 1 that have been shown to produce HID.

8.2 One of the major variables involved in testing for HID of stainless alloy/steel plate is the cooling rate selected for evaluation. Cooling rates as high as 260°C/h have been utilized to intentionally produce disbonding for the purposes of investigating hydrogen disbonding mechanisms. The cooling rate adopted most readily for qualification testing is 150°C/h. Slower cooling rates can be utilized for the purposes of simulating the effects of particular shutdown conditions experienced in refinery equipment. The cooling rate from the test temperature to 200°C shall be controlled and maintained constant while the specimens are in the high-pressure hydrogen environment. Once the temperature of the specimens reaches 200°C, the hydrogen gas environment may be removed and

replaced with inert gas followed by opening of the test vessel to air. Subsequent cooling from 200°C shall be conducted such that the specimens are cooled to ambient temperature by forced air of 30 to 60 m/min around all sides of the specimens while they are supported on ceramic blocks or spacers. If linear cooling can not be obtained in this range with forced air, specimens may be misted with water to provide additional control.

8.3 If simulation of actual conditions is required, these conditions may be modified to better represent the intended refinery service conditions of interest. However, these conditions must be reported. See Section 13.

9. Sampling

9.1 The procedure for sampling stainless alloy bimetallic products should be sufficient to provide specimens that are representative of the plate from which they are taken. The details of this procedure should be covered in product or purchase specifications and are not covered in this practice.

9.2 Sampling of the test environment is recommended to confirm that the test procedure is in conformance with this practice and attains the intended test conditions. The frequency of environmental sampling should be covered in applicable product, purchase, or testing specifications, or both. As a minimum requirement to be in compliance with this practice, sampling of the test environment shall be conducted at the start of testing in a particular apparatus and when any element of the test procedure or test system has been changed or modified.

10. Test Specimens

10.1 The standard test specimen is shown in Fig. 3. It consists of a cylindrical section machined from a stainless alloy/steel plate sample fabricated with methods to be used in the actual equipment fabrication under consideration. The dimensions of the specimen shall be 73 ± 2 mm in diameter and 45 ± 2 mm thick. However, for thinner cross-section materials, the thickness of the specimen may be reduced to match the plate thickness being evaluated.

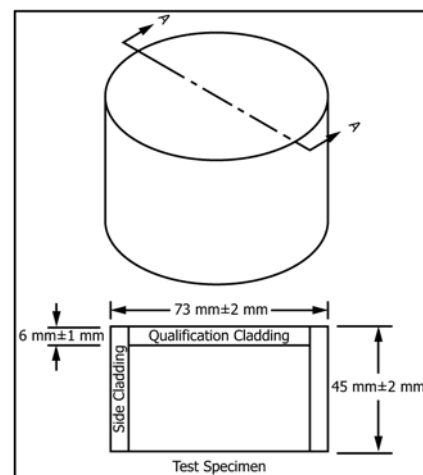

FIG. 3 Test Specimen Configuration