

FINAL
DRAFT

INTERNATIONAL
STANDARD

ISO/FDIS
16657

ISO/TC 34/SC 12

Secretariat: IRAM

Voting begins on:
2023-02-08

Voting terminates on:
2023-04-05

Sensory analysis — Apparatus — Olive oil tasting glass

Analyse sensorielle — Appareillage — Verre pour la dégustation de l'huile d'olive

iTeh STANDARD PREVIEW
(standards.iteh.ai)

[ISO/FDIS 16657](https://standards.iteh.ai/catalog/standards/sist/5937bc78-f4bd-4f6c-8c2e-bffdcc10ad78/iso-fdis-16657)

<https://standards.iteh.ai/catalog/standards/sist/5937bc78-f4bd-4f6c-8c2e-bffdcc10ad78/iso-fdis-16657>

RECIPIENTS OF THIS DRAFT ARE INVITED TO SUBMIT, WITH THEIR COMMENTS, NOTIFICATION OF ANY RELEVANT PATENT RIGHTS OF WHICH THEY ARE AWARE AND TO PROVIDE SUPPORTING DOCUMENTATION.

IN ADDITION TO THEIR EVALUATION AS BEING ACCEPTABLE FOR INDUSTRIAL, TECHNOLOGICAL, COMMERCIAL AND USER PURPOSES, DRAFT INTERNATIONAL STANDARDS MAY ON OCCASION HAVE TO BE CONSIDERED IN THE LIGHT OF THEIR POTENTIAL TO BECOME STANDARDS TO WHICH REFERENCE MAY BE MADE IN NATIONAL REGULATIONS.



Reference number
ISO/FDIS 16657:2023(E)

© ISO 2023

iTeh STANDARD PREVIEW
(standards.iteh.ai)

[ISO/FDIS 16657](https://standards.iteh.ai/catalog/standards/sist/5937bc78-f4bd-4f6c-8c2e-bffdcc10ad78/iso-fdis-16657)

<https://standards.iteh.ai/catalog/standards/sist/5937bc78-f4bd-4f6c-8c2e-bffdcc10ad78/iso-fdis-16657>



COPYRIGHT PROTECTED DOCUMENT

© ISO 2023

All rights reserved. Unless otherwise specified, or required in the context of its implementation, no part of this publication may be reproduced or utilized otherwise in any form or by any means, electronic or mechanical, including photocopying, or posting on the internet or an intranet, without prior written permission. Permission can be requested from either ISO at the address below or ISO's member body in the country of the requester.

ISO copyright office
CP 401 • Ch. de Blandonnet 8
CH-1214 Vernier, Geneva
Phone: +41 22 749 01 11
Email: copyright@iso.org
Website: www.iso.org

Published in Switzerland

Contents

	Page
Foreword.....	iv
1 Scope	1
2 Normative references	1
3 Terms and definitions	1
4 Description of the glass	1
4.1 General.....	1
4.2 Dimensions.....	1
4.3 Manufacturing characteristics.....	2
4.4 Instructions for use.....	2
5 Device for heating samples	2
Annex A (normative) Dimensions of tasting glass for olive oil	3
Annex B (informative) Example of device for heating samples	4
Bibliography	5

iTeh STANDARD PREVIEW
(standards.iteh.ai)

[ISO/FDIS 16657](https://standards.iteh.ai/catalog/standards/sist/5937bc78-f4bd-4f6c-8c2e-bffdcc10ad78/iso-fdis-16657)

<https://standards.iteh.ai/catalog/standards/sist/5937bc78-f4bd-4f6c-8c2e-bffdcc10ad78/iso-fdis-16657>

Foreword

ISO (the International Organization for Standardization) is a worldwide federation of national standards bodies (ISO member bodies). The work of preparing International Standards is normally carried out through ISO technical committees. Each member body interested in a subject for which a technical committee has been established has the right to be represented on that committee. International organizations, governmental and non-governmental, in liaison with ISO, also take part in the work. ISO collaborates closely with the International Electrotechnical Commission (IEC) on all matters of electrotechnical standardization.

The procedures used to develop this document and those intended for its further maintenance are described in the ISO/IEC Directives, Part 1. In particular, the different approval criteria needed for the different types of ISO documents should be noted. This document was drafted in accordance with the editorial rules of the ISO/IEC Directives, Part 2 (see www.iso.org/directives).

Attention is drawn to the possibility that some of the elements of this document may be the subject of patent rights. ISO shall not be held responsible for identifying any or all such patent rights. Details of any patent rights identified during the development of the document will be in the Introduction and/or on the ISO list of patent declarations received (see www.iso.org/patents).

Any trade name used in this document is information given for the convenience of users and does not constitute an endorsement.

For an explanation of the voluntary nature of standards, the meaning of ISO specific terms and expressions related to conformity assessment, as well as information about ISO's adherence to the World Trade Organization (WTO) principles in the Technical Barriers to Trade (TBT), see www.iso.org/iso/foreword.html.

This document was prepared by Technical Committee ISO/TC 34, *Food products*, Subcommittee SC 12, *Sensory analysis*.

This second edition cancels and replaces the first edition (ISO 16657:2006), which has been technically revised.

The main changes are as follows:

- in 2.4, the water used for rinsing the glass has been modified to delete "distilled";
- the Bibliography has been updated.

Any feedback or questions on this document should be directed to the user's national standards body. A complete listing of these bodies can be found at www.iso.org/members.html.

Sensory analysis — Apparatus — Olive oil tasting glass

1 Scope

This document specifies the characteristics of a glass intended for use in the sensory analysis of the organoleptic attributes of odour, taste and flavour of virgin olive oils, for the classification of such oils.

The glass does not apply for the analysis of the colour or texture of olive oils.

In addition, this document describes an adapted heating unit used to reach and maintain the right temperature for this analysis.

2 Normative references

There are no normative references in this document.

3 Terms and definitions

No terms and definitions are listed in this document.

ISO and IEC maintain terminology databases for use in standardization at the following addresses:

- ISO Online browsing platform: available at <https://www.iso.org/obp>
- IEC Electropedia: available at <https://www.electropedia.org/>

4 Description of the glass

4.1 General

The optimum characteristics desirable in a piece of apparatus of this kind can be specified as follows:

- a) maximum steadiness, to prevent the glass from tilting and the oil from being spilled;
- b) a base that easily fits the indentations of the heating unit so that the bottom of the glass is evenly heated;
- c) a narrow mouth, which helps to concentrate the odours and facilitates their identification;
- d) made of dark-coloured glass to prevent the taster from perceiving the colour of the oil, thus eliminating any prejudices and impeding the possible formation of biases or tendencies that can affect the objectivity of the determination.

4.2 Dimensions

The glass, shown in [Annex A](#), shall have the following dimensions:

- Total capacity: 130 ml ± 10 ml
- Total height: 60 mm ± 1 mm

- Diameter of mouth: 50 mm ± 1 mm
- Diameter of glass at its widest: 70 mm ± 1 mm
- Base diameter: 35 mm ± 1 mm
- Thickness of glass on sides: 1,5 mm ± 0,2 mm
- Thickness of glass base: 5 mm ± 1 mm

Each glass shall be equipped with a watch-glass, the diameter of which shall be 10 mm larger than the mouth of the glass. This watch-glass shall be used as a cover to prevent the loss of aroma and the entry of dust.

4.3 Manufacturing characteristics

The glass shall be made of resistant glass. It shall be dark coloured so that the colour of its contents cannot be discerned, and it shall be free from scratches or bubbles.

The rim shall be even, smooth and flanged.

The glass shall be annealed so that it withstands the temperature changes it has to undergo in the tests.

4.4 Instructions for use

The glasses shall be cleaned using unperfumed soap or detergent and shall then be rinsed repeatedly until the cleaning agent has been totally eliminated. The final rinse shall be with water, after which the glasses shall be left to drain and then dried in a desiccation stove.

Neither concentrated acids nor chromic acid mixtures shall be used.

The glasses shall be kept in the stove until required for use, or shall be kept in a cupboard in which they shall be protected from contamination by any extraneous odours.

5 Device for heating samples

The samples shall be sensorially examined at a set temperature which, in the case of virgin olive oils, shall be between 28 °C and 30 °C. For this purpose, a heating device (see [Annex B](#) for an example) shall be installed in each booth within the taster's reach.

Annex A (normative)

Dimensions of tasting glass for olive oil

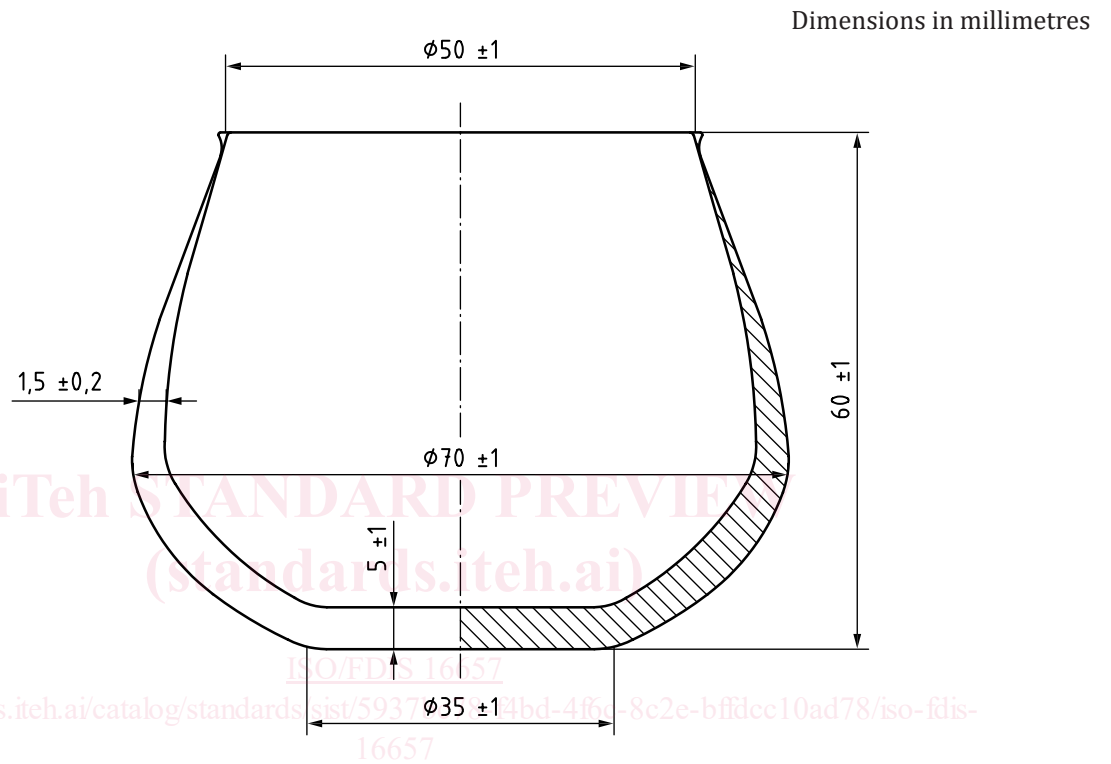
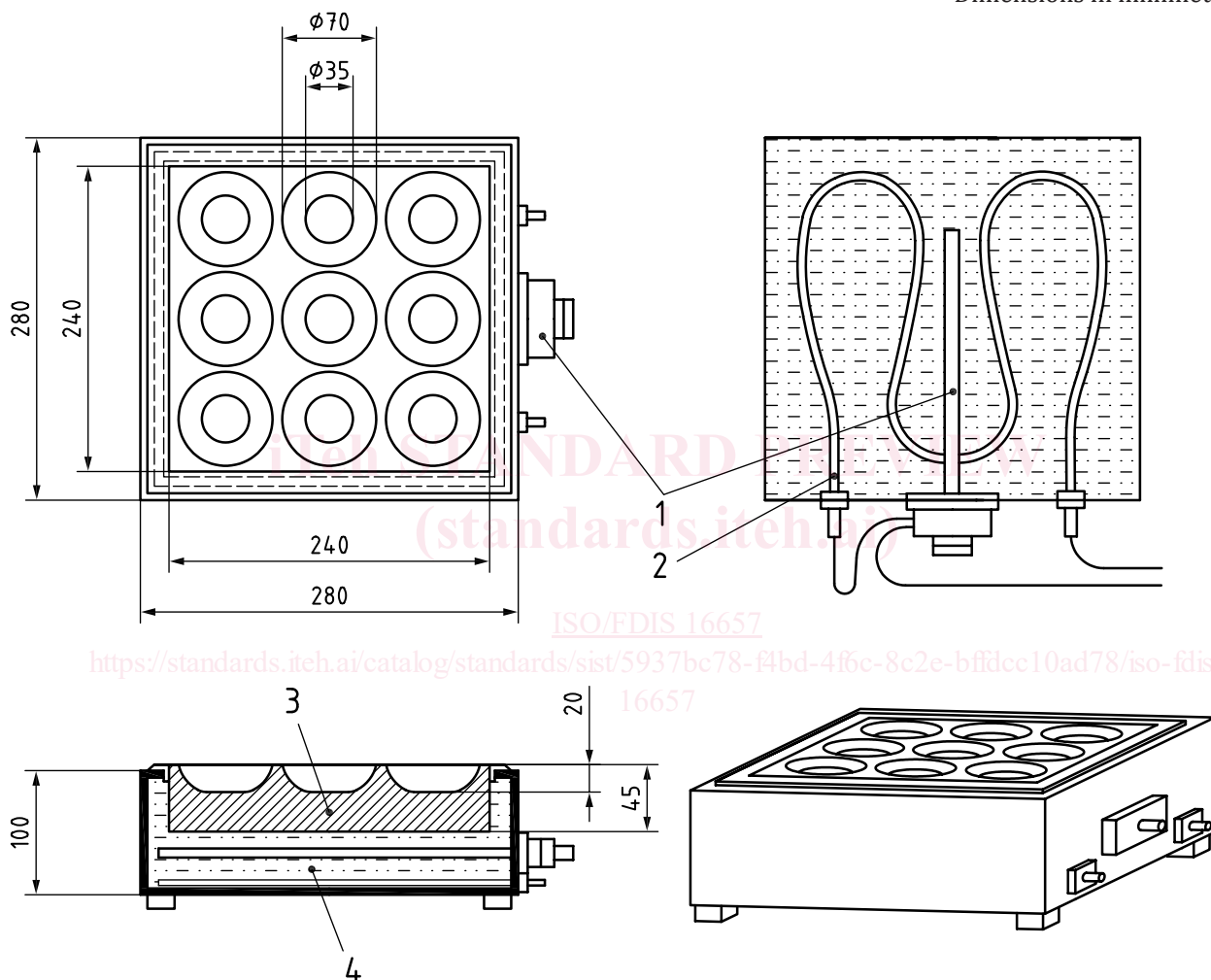

Figure A.1 — Dimensions of tasting glass for olive oil

Annex B (informative)

Example of device for heating samples

Dimensions in millimetres



Key

- 1 thermostat
- 2 heating coil
- 3 aluminium block
- 4 water bath

Figure B.1 — Example of device for heating samples

Bibliography

- [1] International Olive Council. *Sensory Analysis of Olive Oil: Method for the Organoleptic Assessment of Virgin Olive Oil*. COI/T.20/Doc. No 15/Rev. 10, 2018
- [2] International Olive Council. *Sensory Analysis of Olive Oil: Standard Glass For Oil Tasting*. COI/T.20/Doc. No 5/Rev. 2, 2020

iTeh STANDARD PREVIEW
(standards.iteh.ai)

[ISO/FDIS 16657](https://standards.iteh.ai/catalog/standards/sist/5937bc78-f4bd-4f6c-8c2e-bffdc10ad78/iso-fdis-16657)

<https://standards.iteh.ai/catalog/standards/sist/5937bc78-f4bd-4f6c-8c2e-bffdc10ad78/iso-fdis-16657>

iTeh STANDARD PREVIEW
(standards.iteh.ai)

ISO/FDIS 16657

<https://standards.iteh.ai/catalog/standards/sist/5937bc78-f4bd-4f6c-8c2e-bffdc10ad78/iso-fdis-16657>