



Designation: **C230/C230M—08 C230/C230M – 13**

## Standard Specification for Flow Table for Use in Tests of Hydraulic Cement<sup>1</sup>

This standard is issued under the fixed designation C230/C230M; the number immediately following the designation indicates the year of original adoption or, in the case of revision, the year of last revision. A number in parentheses indicates the year of last reappraisal. A superscript epsilon ( $\epsilon$ ) indicates an editorial change since the last revision or reappraisal.

### 1. Scope\*Scope

1.1 This specification covers requirements for the flow table and accessory apparatus (**Note 1**) used in making flow tests for consistency of mortars in tests of hydraulic cement, such as but not limited to Test Method **C1437**.

**NOTE 1**—To help clarify the design of the flow table and accessory apparatus see the drawing in **Fig. 1** [**Fig. 2**]. This drawing is for informational purposes only.

1.2 The values stated in either SI units or inch-pound units are to be regarded separately as standard. The values stated in each system may not be exact equivalents; therefore, each system shall be used independently of the other. Combining values from the two systems may result in non-conformance with the standard. It is permissible to use an inch-pound caliper and mold with a SI flow table or a SI caliper and mold with an inch-pound flow table. It is not permissible to mix a SI mold with an inch-pound caliper or an inch-pound mold with a SI caliper.

1.3 *This standard does not purport to address all of the safety concerns, if any, associated with its use. It is the responsibility of the user of this standard to establish appropriate safety and health practices and determine the applicability of regulatory limitations prior to use.*

### 2. Referenced Documents

2.1 *ASTM Standards:*<sup>2</sup>

**C1437** Test Method for Flow of Hydraulic Cement Mortar

### 3. Flow Table and Frame

3.1 The flow table apparatus shall consist of an integrally cast rigid iron frame and a circular rigid table top  $10 \pm 0.1$  in. [ $255 \pm 2.5$  mm] in diameter, with a shaft attached perpendicular to the table top by means of a screw thread. The table top and shaft with contact shoulder shall be mounted on a frame in such a manner that it can be raised and dropped vertically through the specified height of  $0.500 \pm 0.005$  in. [ $12.7 \pm 0.13$  mm] for new tables and of  $0.500 \pm 0.015$  in. [ $12.7 \pm 0.38$  mm] for tables in use, by means of a rotated cam. The table top shall have a fine machined plane surface, free of blowholes and surface defects. The top shall be scribed with eight equidistant lines  $2\frac{5}{8}$  in. [ $68$  mm] long, extending from the outside circumference toward the center of the table. Each line shall end with a scribed arc,  $\frac{1}{4}$  in. [ $6$  mm] long, whose center point is the center of the table top with a radius of  $2\frac{3}{8}$  in. [ $59.5$  mm]. The scribe lines shall be made with a  $60^\circ$  tool to a depth of 0.01 in. [ $0.25$  mm]. The table top shall be of cast brass or bronze having a Rockwell hardness number not less than 25 HRB with an edge thickness of 0.3 in. [ $7.5$  mm], and shall have six integral radial stiffening ribs. The table top and attached shaft shall weigh  $9 \pm 0.1$  lb [ $4.08 \pm 0.05$  kg] and the weight shall be symmetrical around the center of the shaft.

3.2 The cam and vertical shaft shall be of medium carbon machinery steel, hardened on the end of the shaft contacting the cam and the tip of the cam contacting the shaft. The shaft shall be straight and the difference between the diameter of the shaft and the diameter of the bore of the frame shall be not less than 0.002 in. [ $0.05$  mm] and not more than 0.003 in. [ $0.08$  mm] for new tables and shall be maintained at 0.002 to 0.010 in. [ $0.05$  to  $0.25$  mm] for tables in use. The end of the shaft shall not fall upon the cam at the end of the drop, but shall make contact with the cam not less than  $120^\circ$  from the point of drop. The face of the cam shall be a smooth spiraled curve of uniformly increasing radius from  $\frac{1}{2}$  to  $1\frac{1}{4}$  in. [ $13$  to  $32$  mm] in  $360^\circ$  and there shall be no appreciable jar as the shaft comes into contact with the cam. The cam shall be so located and the contact faces of the cam and shaft shall be such that the table does not rotate more than one revolution in 25 drops. The surfaces of the frame and of the table that come into

<sup>1</sup> This specification is under the jurisdiction of ASTM Committee **C01** on Cement and is the direct responsibility of Subcommittee **C01.22** on Workability. Current edition approved July 1, 2008; June 1, 2013. Published August 2008; July 2013. Originally approved in 1949. Last previous edition approved in 2003; 2008 as **C230/C230M—03**; **C230/C230M—08**. DOI: 10.1520/C0230-C0230M-08-10.1520/C0230\_C0230M-13.

<sup>2</sup> For referenced ASTM standards, visit the ASTM website, [www.astm.org](http://www.astm.org), or contact ASTM Customer Service at [service@astm.org](mailto:service@astm.org). For *Annual Book of ASTM Standards* volume information, refer to the standard's Document Summary page on the ASTM website.

\*A Summary of Changes section appears at the end of this standard

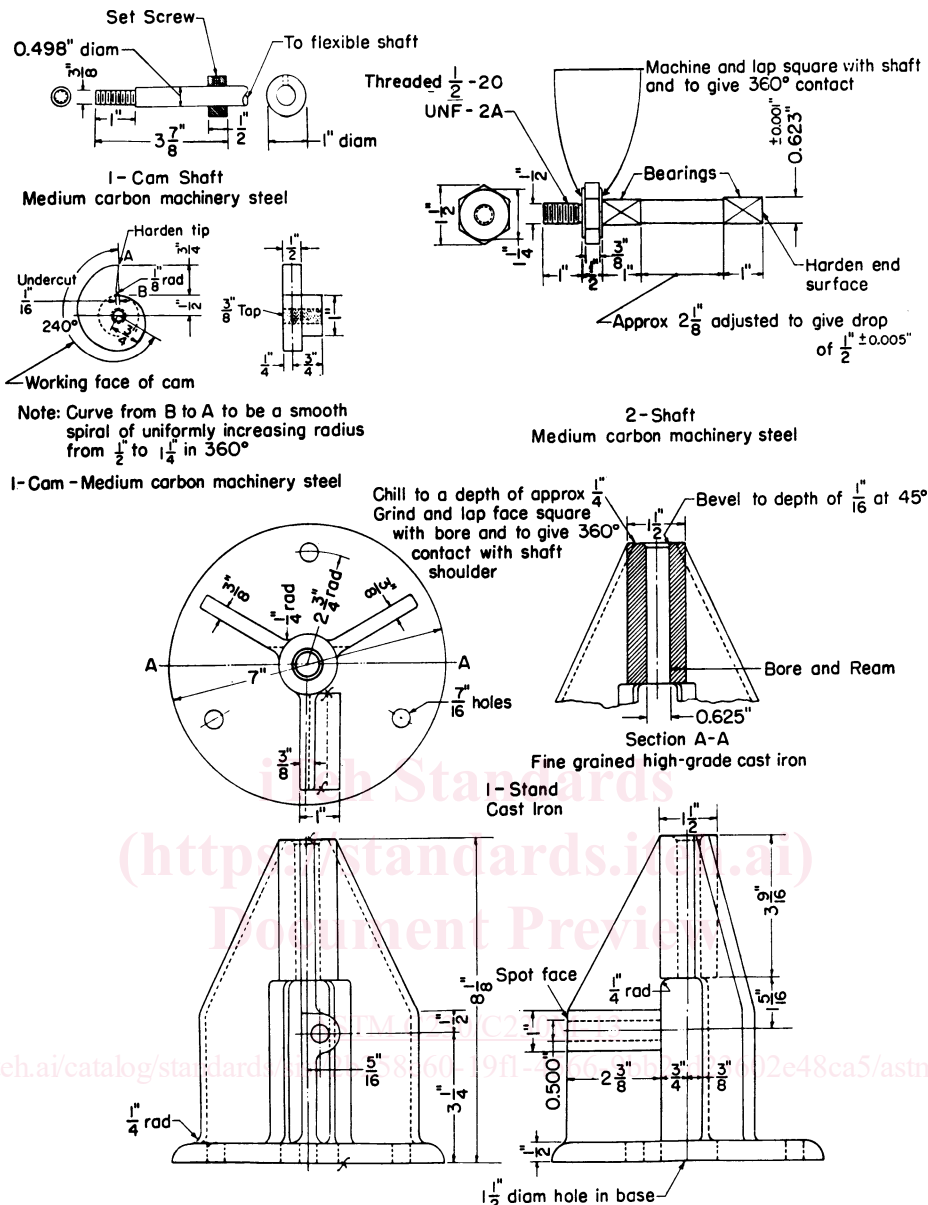

FIG. 1 Flow Table and Accessory Apparatus (Partial) (In./Lb)(in./lb)

contact at the end of the drop shall be maintained smooth, plane, and horizontal and parallel with the upper surface of the table and shall make continuous contact over a full 360°.

3.3 The supporting frame of the flow table shall be integrally cast of fine-grained, high-grade cast iron. The frame casting shall have three integral stiffening ribs extending the full height of the frame and located 120° apart. The top of the frame shall be chilled to a depth of approximately 1/4 in. [6 mm], and the face shall be ground and lapped square with the bore to give 360° contact with the shaft shoulder. The underside of the base of the frame shall be ground to secure a complete contact with the steel plate beneath.

3.4 The flow table shall be driven by a motor (Note 2), connected to the cam shaft through an enclosed worm gear speed reducer and flexible coupling. The speed of the cam shaft shall be approximately 100 r/min. The motor drive mechanism shall not be fastened or mounted on the table base plate or frame.

NOTE 2—A 1/20-hp [40-W] motor has been found adequate.

3.5 The performance of a flow table shall be considered satisfactory if, in calibration tests, the table gives a flow value that does not differ by more than 5 percentage points from flow values obtained with a suitable calibration material.<sup>3,4</sup> (See Note 3.)

<sup>3</sup> Such a material can be obtained from the Cement and Concrete Reference Laboratory at the National Institute of Standards and Technology, Gaithersburg, MD 20899-(http://www.ccril.us/).

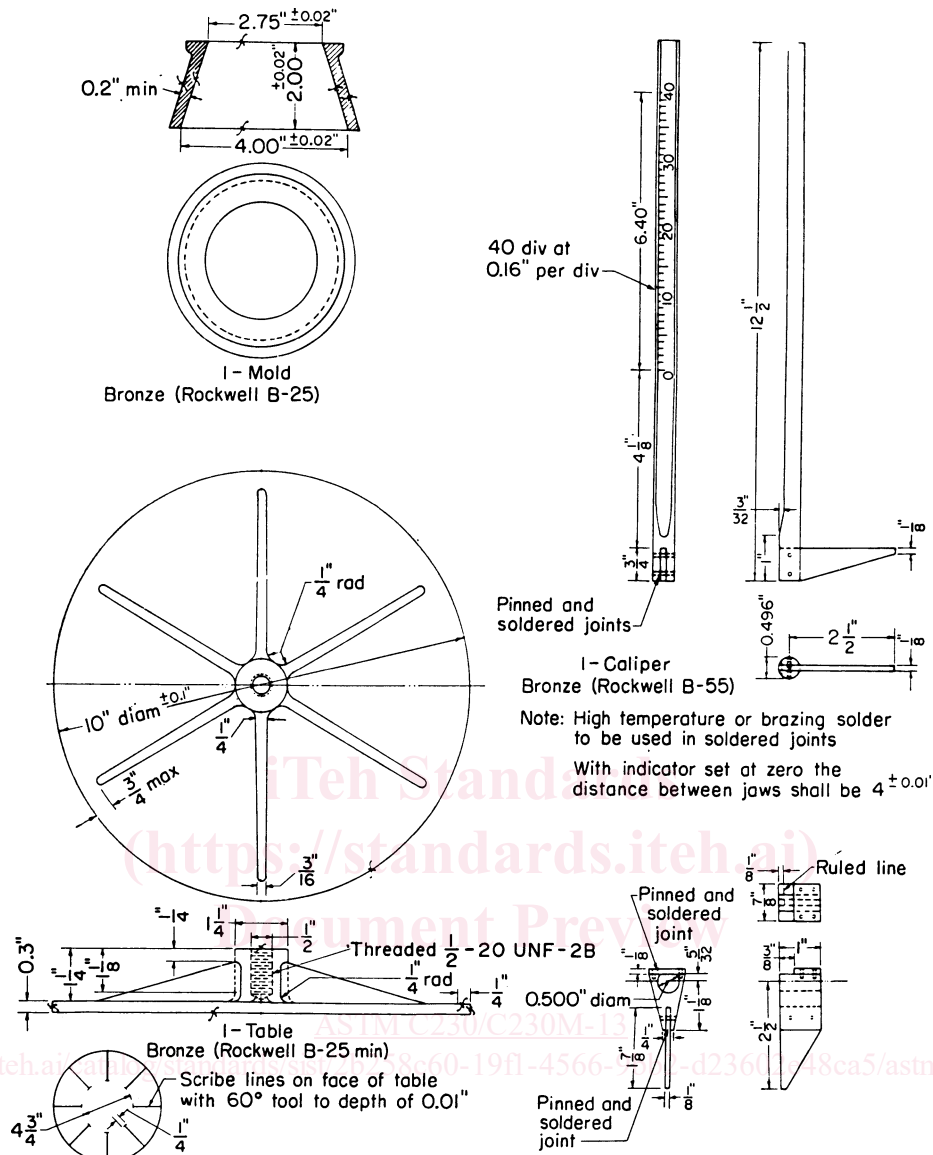

FIG. 1 Flow Table and Accessory Apparatus (Partial) (In./Lb)(in./lb) (continued)

NOTE 3—Some causes of and solutions to unsatisfactory performance of the flow table may be found in the section on flow tables in the *ASTM Manual of Cement Testing*.

#### 4. Flow Table Mounting

4.1 The flow table frame shall be tightly bolted to a cast iron or steel plate at least 1 in. [25 mm] thick and 10 in. [250 mm] square. The top surface of this plate shall be machined to a smooth plane surface. The plate shall be anchored to the top of a concrete pedestal by four  $\frac{1}{2}$ -in. [13-mm] bolts that pass through the plate and are imbedded at least 6 in. [150 mm] in the pedestal. The pedestal shall be cast inverted on the base plate. A positive contact between the base plate and the pedestal shall be obtained at all points. No nuts or other such leveling devices shall be used between the plate and the pedestal. Leveling shall be effected by suitable means under the base of the pedestal.

4.2 The pedestal shall be 10 to 11 in. [250 to 275 mm] square at the top, and 15 to 16 in. [375 to 400 mm] square at the bottom, 25 to 30 in. [625 to 750 mm] in height, and shall be of monolithic construction, cast from concrete weighing at least  $140 \text{ lb/ft}^3$  [ $2240 \text{ kg/m}^3$ ]. A stable gasket cork padding,  $\frac{1}{2}$  in. [13 mm] thick and the same size as the pedestal bottom or four pieces of padding  $\frac{1}{2}$  in. [13 mm] thick and approximately 4 in. [100 mm] square, shall be inserted under the pedestal or the four corners, respectively. The flow table shall be checked frequently for levelness of the table top, stability of the pedestal, and tightness of the bolts and nuts in the table base and the pedestal table. (A torque of 20 lb-ft [27 N·m] is recommended when tightening those fastenings.)

<sup>4</sup> Supporting data have been filed at ASTM International Headquarters and may be obtained by requesting Research Report RR:C01-1006.