



Designation: F432 – 13

Standard Specification for Roof and Rock Bolts and Accessories¹

This standard is issued under the fixed designation F432; the number immediately following the designation indicates the year of original adoption or, in the case of revision, the year of last revision. A number in parentheses indicates the year of last reapproval. A superscript epsilon (ϵ) indicates an editorial change since the last revision or reapproval.

1. Scope*

1.1 This specification covers the chemical, mechanical, and dimensional requirements for roof and rock bolts and accessories. Addressed in this specification are double-end threaded and slotted steel bars; fully grouted bolts and threaded bars; mechanical anchorage devices used for point anchorage applications; roof truss systems; partially grouted deformed bolts; formable anchorage devices; cable bolt systems; expandable rock bolts and other frictional anchorage devices. All of these products represent various designs used for ground support systems. This specification can be revised to address new technologies.

1.2 The values stated in inch-pound units are to be regarded as standard. No other units of measurement are included in this standard.

1.3 This hazard statement applies only to Section 10, Test Methods of this specification. *This standard does not purport to address the safety concerns, if any, associated with its use. It is the responsibility of the user of this standard to establish appropriate safety and health practices and determine the applicability of regulatory limitations prior to use.*

2. Referenced Documents

2.1 ASTM Standards:²

- A29/A29M Specification for General Requirements for Steel Bars, Carbon and Alloy, Hot-Wrought
- A47/A47M Specification for Ferritic Malleable Iron Castings
- A194/A194M Specification for Carbon and Alloy Steel Nuts for Bolts for High Pressure or High Temperature Service, or Both
- A220/A220M Specification for Pearlitic Malleable Iron
- A370 Test Methods and Definitions for Mechanical Testing of Steel Products

¹ This specification is under the jurisdiction of ASTM Committee F16 on Fasteners and is the direct responsibility of Subcommittee F16.02 on Steel Bolts, Nuts, Rivets and Washers.

Current edition approved May 1, 2013. Published July 2013. Originally approved in 1975. Last previous edition approved in 2010 as F432 – 10. DOI: 10.1520/F0432-13.

² For referenced ASTM standards, visit the ASTM website, www.astm.org, or contact ASTM Customer Service at service@astm.org. For *Annual Book of ASTM Standards* volume information, refer to the standard's Document Summary page on the ASTM website.

- A416/A416M Specification for Steel Strand, Uncoated Seven-Wire for Prestressed Concrete
- A536 Specification for Ductile Iron Castings
- A563 Specification for Carbon and Alloy Steel Nuts
- A615/A615M Specification for Deformed and Plain Carbon-Steel Bars for Concrete Reinforcement
- A882/A882M Specification for Filled Epoxy-Coated Seven-Wire Prestressing Steel Strand
- A1011/A1011M Specification for Steel, Sheet and Strip, Hot-Rolled, Carbon, Structural, High-Strength Low-Alloy, High-Strength Low-Alloy with Improved Formability, and Ultra-High Strength
- A751 Test Methods, Practices, and Terminology for Chemical Analysis of Steel Products
- D6637 Test Method for Determining Tensile Properties of Geogrids by the Single or Multi-Rib Tensile Method
- D1248 Specification for Polyethylene Plastics Extrusion Materials for Wire and Cable
- F436 Specification for Hardened Steel Washers
- F606 Test Methods for Determining the Mechanical Properties of Externally and Internally Threaded Fasteners, Washers, Direct Tension Indicators, and Rivets

2.2 ASME Standards:³

- B 1.1 Unified Screw Threads
- B 1.3M Screw Thread Gaging Systems for Dimensional Acceptability—Inch and Metric Screw Threads
- B 18.2.2 Square and Hex Nuts

3. Terminology

3.1 Definitions:

3.1.1 *barrel*—a device housing normally either 2 or 3 piece cable strand wedges

3.1.2 *bearing plates, plate washers, mine roof plates*—plates that serve to distribute the load from the exposed end of the bolt or threaded bar to the rock face or intermediate member.

3.1.2.1 *header plates*—large rectangular bearing plates, usually 6 in. wide by 16 to 18 in. long, or any other shape with an equivalent area, used in substitution for wooden header blocks

³ Available from American Society of Mechanical Engineers (ASME), ASME International Headquarters, Three Park Ave., New York, NY 10016-5990, http://www.asme.org.

*A Summary of Changes section appears at the end of this standard

for wider distribution of the bolt load than is possible with standard bearing plates.

3.1.3 *bendable bolts*—bolts furnished with an altered section at some location, to be specified by the customer, at which the bar will bend.

3.1.3.1 *Discussion*—Bending is necessary to permit installation of bars longer than the mine opening height. This altered section may be produced by hot or cold forging, or by shearing, sawing, trimming, machining, grinding, or a combination of these processes.

3.1.4 *beveled washers*—washers whose faces are at an angle permitting a headed bolt or threaded bar to be installed at a slight angle to the rock face and yet maintained the face of the bolt head perpendicular to the bolt axis.

3.1.5 *cable bolt*—cable strand with an assembly placed on the end for installation and load resistance purposes.

3.1.6 *chemical anchors*—chemical materials that provide anchorage between the bolt or bar and the drilled hole.

3.1.7 *discontinuous turn*—discontinuous turn shall include material heat changes, interruptions to the manufacturing operation exceeding 8 hrs, and significant machinery adjustments that materially alter the manufacturing process. The discontinuous turn shall apply to all separate manufacturing stations separate from the material heat change criteria. A material length change will not constitute a “discontinuous turn” as provided in this definition.

3.1.8 *expandable rock bolt*—rock support device that consists of a steel tube, folded or collapsed on itself, that can be inserted into a borehole and expanded, by means of high internal pressure, against the wall of the borehole. The product anchorage is developed through a combination of friction and mechanical interlock of the expanded profile against the borehole wall after the internal expansion pressure used for installation has been relieved.

3.1.9 *expansion shells*—anchorage devices that, separate from the bar or bolt, mechanically expand to grip the sides of a drilled hole and transfer load between the location of the anchor to the bar or bolt.

3.1.10 *extensions*—threaded bars used to extend the length of threaded or threaded slotted bars.

3.1.11 *formable anchorage devices*— any roof support devices that provide anchorage through some means of physical interference and engagement of the surface of a bar or bolt with any formable material, other than chemical grout, in a borehole.

3.1.12 *frictional anchorage devices*—ground support devices, friction stabilizers, that are designed so that the holding force/anchorage is generated by frictional forces between the surface of the borehole and the surface of the device. The frictional forces can be active over the full or partial length of the device.

3.1.13 *fully grouted bolts and threaded bars*—deformed bars or plain bars used with full-length grouting and having special deformations or other design features to provide interlocking between the steel and the grout.

3.1.14 *hardened washers*—washers that have been hardened by heat treatment to provide consistency to the torque tension relation necessary to control installation tension of bolts and threaded bars.

3.1.15 *minimum non-seizure load (MNSL)*—the load level in pounds through which bolt/plug thread seizure must not occur.

3.1.16 *minimum ultimate load (MUL)*—the load level in pounds through which bolt/plug thread failure must not occur.

3.1.17 *rollers, cams*—moving devices that, when used with internally threaded cylinders containing external tapered slots, provide expansion to grip the sides of a drilled hole mechanically and transfer load from the location of the anchor to the bar or bolt.

3.1.18 *roof and rock bolts*—headed hot-rolled bars with cold-rolled or machine-cut threads at the end, to be used with anchorage devices to hold up mine roofs, hold back walls, or hold down equipment or foundations.

3.1.19 *roof truss system*—a roof support system incorporating bolts that are joined together by crossmember(s) that is (are) tensioned by design.

3.1.20 *strand*—a group of wires normally having helically placed outer wires with uniform pitch.

3.1.21 *spherical washers or seats*—washers that are flat on one side and have a spherical face on the other side. The combination of spherical washer together with a depression in the bearing plate produces a ball-and-socket joint permitting bolts to be installed at a slight angle to the rock face while still maintaining the face of the bolt head perpendicular to the bolt axis.

3.1.22 *tapered wedges*—plain wedges that provide the expansion for threaded slotted bars.

3.1.23 *tension nuts*—nuts that are intended to induce and maintain tension in a bolt.

3.1.24 *threaded bars*—bars that are used with a nut on one end and an anchorage device on the other. They are used in a manner similar to the bolts described in 3.1.18.

3.1.25 *threaded couplings*—couplings used to permit the assembly of additional externally threaded items.

3.1.26 *threaded slotted bars*—bars threaded at one end each with a forged, burned, or sawed slot at the other, into which a tapered wedge can be inserted. When each assembly is driven into a bottomed hole, the wedge spreads the slot and an anchorage is produced.

3.1.27 *threaded tapered plugs*—threaded wedge that expands the expansion shell by the movement of the threaded plug within the shell as tightening progresses.

3.1.28 *wedge*—pieces of tapered metal with teeth which bite into the strand under load.

3.1.28.1 *Discussion*—Two or three piece wedges are normally used.

4. Ordering Information

4.1 Orders for material under this specification shall include at least the following information:

4.1.1 Quantity (number of pieces),

4.1.2 Name of product together with description of accessories,

4.1.3 Dimensions,

4.1.4 ASTM designation and year of issue, including strength grade,

4.1.5 Special requirements, if any, including packaging and thread protection instructions, and

4.1.6 Certifications, if required.

4.2 The products covered by this specification are currently produced by many manufacturers to a wide variety of designs. It is necessary for the user and the manufacturer to establish the requirements of the individual installation and to agree as to the type of assembly to be employed. See [Annex A1](#) and [Appendix X1](#) for additional information.

5. Manufacturing Processes

5.1 *Materials for Bolts, Extensions, and Threaded or Threaded Slotted Bars:*

5.1.1 Steel shall conform to the requirements shown in [Table 1](#) and in Specification [A29/A29M](#) for plain bars or Specification [A615/A615M](#) for plain or deformed bars unless otherwise specified.

5.1.1.1 Threaded slotted bars may have the slot produced by forging, burning, or sawing. Burned slots of Grades 55 and 75 threaded slotted bars must have the slotted end normalized by heating to a minimum of 1600°F and air cooling subsequent to burning.

5.1.1.2 Threads on bolts or threaded bars may be cold rolled or machine cut on the hot-rolled bars.

5.1.2 Steel strands for use as cable bolts shall conform to Specification [A416/A416M](#).

5.1.3 Filled epoxy steel strands for use as cable bolts shall conform to Specification [A882/A882M](#).

5.2 *Materials for Tapered Wedges for Use With Threaded Slotted Bars:*

5.2.1 Malleable iron casting shall conform to Specification [A47/A47M](#).

5.2.2 Pearlitic malleable iron castings shall conform to Specification [A220/A220M](#), Grades 45006 or 50005.

5.2.3 Steel shall conform to the requirements shown in [Table 1](#).

5.3 *Materials for Expansion Shells:*

5.3.1 Malleable iron castings shall conform to Specification [A47/A47M](#).

5.3.2 Steel shall conform to the requirements shown in [Table 1](#).

5.3.3 Ductile iron castings shall conform to Specification [A536](#), Grades 60-40-18.

5.4 *Materials for Threaded Tapered Plugs Used with Expansion Shells:*

5.4.1 Materials for threaded tapered plugs used with expansion shells shall conform to the test specifications in [10.8](#).

5.5 *Materials for Bearing and Header Plates, Also Known As Plate Washers or Mine Roof Plates:*

5.5.1 Steel shall conform to the requirements shown in [Table 1](#).

5.5.1.1 Bearing and header plates may be strengthened by cold forming or may be hardened by quenching in a liquid medium from above the austenitizing temperature and tempering at a temperature of not less than 650°F.

5.6 *Materials for Spherical, Flat, or Beveled Hardened Washers:*

5.6.1 Steel shall conform to the requirements shown in [Table 1](#).

5.6.1.1 Hardened steel washers shall be through hardened by quenching in a liquid medium from above the austenitizing temperature and tempering at a temperature of not less than 650°F. Case-hardened washers are not permitted.

5.7 *Materials for Spherical or Beveled Washers:*

5.7.1 Malleable iron castings shall conform to Specification [A47/A47M](#).

5.7.2 Pearlitic malleable iron castings shall conform to Specification [A220/A220M](#), Grades 45006, 50005, or 60004.

5.7.3 Steel shall conform to the requirements shown in [Table 1](#).

5.8 *Materials for Nuts:*

5.8.1 Nuts shall be in accordance with Specifications [A194/A194M](#) or [A563](#). Appropriate nuts for each grade of threaded bar are shown in [Table 2](#). Higher strength nuts conforming to Specifications [A194/A194M](#) or [A563](#) may be substituted. When specified on the order or contract, nuts with external dimensions of nominal 3/4-in. heavy hex or heavy square size may be supplied with 5/8-in. threads for use with 5/8-in. threaded bars.

5.9 *Materials for Chemical Grouting Materials:*

5.9.1 Chemical grouting materials are covered in [Annex A3](#) of this specification.

TABLE 1 Chemical Requirements

Product	Carbon, max, %		Sulfur, max, %		Phosphorus, max, %	
	Heat	Product	Heat	Product	Heat	Product
Bolts, threaded bars, and threaded slotted bars ^A	0.75	0.79	0.13	^B	0.050	0.058
Steel tapered wedges	0.80	0.84	0.13	^B	0.050	0.058
Hardened spherical, flat, or beveled washers	0.80	0.84	0.050	0.058	0.050	0.058
Spherical or beveled washers	0.80	0.84	0.050	0.058	0.050	0.058
Bearing and header plates	1.00	1.04	0.050	0.058	0.050	0.058
Steel threaded tapered plugs	0.60	0.64	0.13	^B	0.050	0.058
Steel expansion shells	0.30	0.33	0.050	0.058	0.050	0.058

^A Bars furnished in accordance with Specification [A615/A615M](#) may be substituted for these requirements.

^B Check analysis for sulfur if a resulfurized steel is not technically appropriate.

TABLE 2 Appropriate Nuts

Bolt, Threaded Bar, or Threaded Slotted Bar Grade	Nut Specification
30 (regular strength)	A194/A194M , Grade 1; A563 , Grade B
55 (high strength)	A194/A194M , Grade 1; A563 , Grade B
75 (extra high strength)	A194/A194M , Grade 2; A563 , Grade C

5.10 Materials for Threaded Couplings:

5.10.1 Materials for threaded couplings shall be selected by the manufacturer to ensure compliance with 7.6 and 8.6.1.

5.11 Materials for Bolts and Threaded Bars for Use in Grouted Systems—Plain or deformed steel bars shall conform to Table 1 or Specification A615/A615M.

5.12 Materials for Friction Stabilizers—Sheet steel shall conform to requirements specified in Specification A1011/A1011M, Table 2 HSLAS Class 2 material per Table 3.

5.13 Materials for Truss Systems:

5.13.1 Components of roof truss systems shall be manufactured in accordance with the appropriate paragraph(s) of Section 5 of this specification.

5.14 Materials for Formable Anchors:

5.14.1 Materials for formable anchor tubes are as follows:

5.14.1.1 Polyethylenes used for formable anchor tubes shall conform to ASTM D1248 Classification Type III, Class A or B, Category 5.

NOTE 1—All shapes, compositions, and properties of formable anchor materials are not covered by this specification. Users must ensure that the formable anchor material offered is suitable for its intended use.

6. Chemical Composition

6.1 Materials used for bolts, threaded bars, threaded slotted bars, spherical, flat, or beveled washers, threaded tapered plugs, tapered wedges, expansion shells, bearing plates and roof truss components shall be as specified in Table 1 and Section 5.

6.2 Materials for all cast or wrought metallic items other than those covered in 6.1 shall conform to the requirements as specified in Section 5.

6.3 Individual heats of steel or cast iron are not identified in any of the finished products.

6.4 Chemical analyses for steel products shall be performed in accordance with Test Methods, Practices, and Terminology A751.

6.5 Materials for formable anchors shall conform to the requirements, if applicable, specified in Section 5.

6.6 Chemical analyses shall be performed in accordance with Test Methods, Practices, and Terminology A751.

6.7 Material for friction stabilizers shall conform to requirements specified in Specification A1011/A1011M, Table 2 HSLAS Class 2 material per Table 3.

TABLE 3 Mechanical Properties of Sheet Steel for the Manufacture of Friction Stabilizers

Designation ^A	Nominal Diameter, in. ^B	Minimum yield strength, psi ^C
33	1.33	60 000
39	1.54	60 000
46	1.81	50 000

^ADesignation denotes traditional reference to nominal millimeter diameter measurement as previously established.

^BAs measured across bolt diameter perpendicular to the slot as indicated in Fig. 7.

^CPer Specification A1011/A1011M.

7. Mechanical Properties

7.1 Mechanical properties of steel bars, for the manufacture of bolts, threaded bars, or threaded slotted bars shall be as specified in Table 4 for the required grade.

7.2 Mechanical properties of steel bolts, threaded bars, and threaded slotted bars whose slots have been produced without material removal shall be as specified in Table 5 for the required grade.

7.3 Expansion shells, threaded tapered plugs, tapered wedges, and spherical washers shall conform to the applicable specification of Section 5 and shall successfully perform the required purpose as described in Annex A1.

7.4 Bearing plates and header plates that are strengthened by quenching and tempering shall have a maximum hardness of 45 HRC.

7.4.1 Bearing plates and header plates shall be provided in 10 000-lbf grade increments. The minimum grade rating permitted shall be 20 000 lbf.

7.5 Hardened washers shall have a hardness range from 35 to 45 HRC.

7.6 Threaded couplings must be capable of developing the actual yield and tensile values of the bolt, threaded bar, or threaded slotted bar with which they are to be used.

7.7 Extensions must be in accordance with 7.1 and 7.2 for the grade of item specified.

7.8 Mechanical properties for bolts and threaded bars for use in grouted systems shall be as specified in Table 4 for plain bars; and Table 4 or Specification A615/A615M for deformed bars. Bolts and threaded bars made from plain material must contain some design feature to provide interlocking between the steel and the grout. These items can be supplied threaded or headed.

7.9 Threaded slotted bars whose slots have been produced by burning shall be heat treated by normalizing in accordance with 5.1.1. The normalizing heat treatment and the removal of material from the slot, whether it be by burning or sawing, will result in lower test values. When either the burning or sawing

TABLE 4 Mechanical Properties of Steel Bars for the Manufacture of Bolts, Threaded Bars, and Threaded Slotted Bars^{A,B}

Grade	Nominal Diameter, in. ^C	Yield Point min, psi	Tensile Strength min, psi	Elongation in 8 in. or 200 mm Minimum, %
40 ^D	3/4 – 1 1/2	40 000	70 000	12
55	5/8 – 1 1/2	55 000	85 000	12
60 ^D	5/8 – 1 1/2	60 000	90 000	9
75	5/8 – 1 1/2	75 000	100 000	8
100	5/8 – 1 1/2	100 000	125 000	6

^A Test of bars shall be performed full size.

^B Higher grades would be produced in 20 000-psi increments. The minimum tensile strength shall be 25 000 psi above the minimum yield strength. The minimum elongation shall be 4 % for all grades above 100.

^C Actual bar diameters are somewhat less than nominal, especially when roll threading methods are employed.

^D Grade 40 and 60 only apply to deformed bar.

TABLE 5 Load Support Requirements of Steel Bolts, Threaded Bars, Thread Deformed Bars (see Annex A2), and Threaded Slotted Bars Whose Slot Has Been Produced Without Metal Removal^A

Nominal Diameter (in.)/ Thread /in.	Thread Stress Area, in. ²	Grade									
		40 ^B		55		60 ^B		75		100	
		Yield lbs ^C	Ultimate lbs ^C	Yield lbs ^C	Ultimate lbs ^C	Yield lbs ^C	Ultimate lbs ^C	Yield lbs ^C	Ultimate lbs ^C	Yield lbs ^C	Ultimate lbs ^C
5/8 –11	0.226	<i>D</i>	<i>D</i>	12 400	19 200	13 600	20 300	17 000	22 600	22 600	26 300
3/4 –10	0.334	13 400	23 400	18 400	28 400	20 000	30 100	25 100	33 400	33 400	41 800
7/8 –9	0.462	18 500	32 300	25 400	39 300	27 700	41 600	34 700	46 200	46 200	57 800
1 –8	0.606	24 200	42 400	33 300	51 500	36 400	54 500	45 500	60 600	60 600	75 800
1 1/8 –7	0.763	30 500	53 400	42 000	64 900	45 800	68 700	57 200	76 300	76 300	95 400
1 1/4 –7	0.969	38 800	67 800	53 300	82 400	58 100	87 200	72 700	96 900	96 900	121 100
1 3/8 –6	1.155	46 200	80 900	63 500	96 200	69 300	104 000	86 600	115 500	115 500	144 400
1 1/2 –6	1.405	56 200	98 400	77 300	119 400	84 300	126 500	105 400	140 500	140 500	175 600

^A Tests of bolts and threaded bars shall be performed using full-diameter products.

^B Information for Gr 40 and 60 only applies to deformed bars.

^C Required yield and tensile loads shown are calculated by multiplying thread stress areas times the yield point and tensile strength values shown in Table 3. Thread stress area is calculated from the mean root and pitch diameters of adrenal threads as follows:

$$A_s = 0.7854 \left(D - \frac{0.9743}{n} \right)^2$$

where:

- A_s = stress area, in.²
- D = nominal diameter, in., and
- n = number of threads per inch.

^D 5/8 in. Gr 40 products are not covered.

or other methods involving metal removal are used, the mechanical properties of threaded slotted bolts shall be as specified in Table 6.

7.10 Threaded tapered plugs for expansion anchors must be capable of withstanding the minimum nonseizure load (MNSL) and minimum ultimate load (MUL), in accordance with Table 7.

7.11 Tension nuts must be capable of withstanding the ultimate tensile strength of the bolt or rebar of the highest grade with which they are to be used.

7.12 The mechanical properties of components of roof truss systems shall be in accordance with the appropriate paragraph(s) of this section.

TABLE 6 Load Support Requirements for Threaded Slotted Bars Whose Slot Has Been Produced by Methods Involving Metal Removal^A

Nominal Diameter, in.	Thread Stress Area, min, in. ²	Grade 55	
		Yield Load, min, lbf ^B	Ultimate Tensile Load, min, lbf ^B
1	0.606	30 000	46 400
1 1/4	0.969	48 000	74 200
1 3/8	1.155	57 200	88 400
1 1/2	1.405	69 600	107 500

^A Tests of bolts, threaded bars, and threaded slotted bars shall be performed using full-diameter products.

^B Required yield and tensile loads shown are calculated by multiplying thread stress areas times the yield point and tensile strength values shown in Table 2. Thread stress area is calculated from the mean of the mean root and pitch diameters of Class 3 external threads as follows:

$$A_s = 0.7854 \left(D - \frac{0.9743}{n} \right)^2$$

where:

- A_s = stress area, in.²
- D = nominal diameter, in., and
- n = number of threads per inch.

TABLE 7 Plug Grade Rating System

Nominal Diameter, in.	Grade 1		Grade 2		Grade 3		Grade 4	
	MNSL ^A	MUL ^B	MNSL ^A	MUL ^B	MNSL ^A	MUL ^B	MNSL ^A	MUL ^B
1/2	7.0	14.2	10.7	17.0	13.5	19.9	16.3	22.7
5/8	12.4	22.6	17.0	27.1	21.5	31.6	26.0	36.1
3/4	18.4	33.4	25.1	40.1	31.7	46.8†	38.4	53.4†
7/8	25.4†	46.2	34.7	55.4	40.0	64.7	40.0	73.9
1	33.3	60.6	40.0	72.7	40.0	84.8	40.0	96.9
1 1/8	40.0	76.3	40.0	91.6	40.0	106.8	40.0	122.0
1 1/4	40.0	96.9	40.0	116.3	40.0	135.7	40.0	155.0†
1 3/8	40.0	115.5†	40.0	138.6	40.0	161.7	40.0	184.8
1 1/2	40.0	140.5†	40.0	168.6	40.0	196.7	40.0	224.8

^A MNSL—Minimum Non-Seizure Load (1000 lb).

^B MUL—Minimum Ultimate Load (1000 lb).

7.12.1 Truss brackets shall be provided in 10 000-lbf grade increments.

7.13 Formable anchor materials shall conform to the applicable specifications of Section 5.

7.14 Mechanical properties for friction stabilizer shall conform to requirements specified in Specification A1011/A1011M, Table 4 HSLAS, Class 2 material. Specific mechanical properties for various size friction stabilizers are listed in Table 3 and Table 8.

7.15 Cable bolts, when pull tested to failure against the head assembly, must achieve 90% of the minimum breaking strength per Specification A416/A416M

7.16 Mechanical properties for expandable rock bolts shall meet manufacturer’s stated minimum yield, ultimate load, and elongation as per testing requirement defined in 10.16.

8. Dimensions, Mass, and Permissible Variations

8.1 Threaded bolts shall conform to the dimensions shown in Fig. 1.

TABLE 8 Load Support and Dimensional Requirements for Friction Stabilizers

Designation ^A	Nominal Diameter, in. ^B	Minimum Ultimate Load, lbs	OD tolerance, in.	Length Tolerance, in. ^C
33	1.33	20 000	± 0.03	+1/4, -1/2
39	1.54	23 000	+ 0.02, -0.04	+1/4, -1/2
46	1.81	32 500	± 0.03	+1/4, -1/2

^ADesignation denotes traditional reference to nominal millimeter diameter measurement as previously established.

^BAs measured across bolt diameter perpendicular to the slot as indicated in Fig. 7

^CBolt length is measured end-to-end (actual friction stabilizer tubing length).

8.1.1 Deformed bar bolts are bars that have been forged to produce one of the standard heads described in Fig. 1.

8.2 Threaded and threaded slotted bars shall conform to the dimensions shown in Fig. 2.

8.3 Thread Requirements:

NOTE 2—Thread size variations can be expected due to bar diameter and out-of-round variations. These special requirements reflect practices for external and internal threads that have been found to provide adequate strength and interchangeability.

8.3.1 External threads shall be in accordance with ASME B 1.1 UNC 1A except that the minimum pitch diameter has been reduced by 0.003 in. and the minimum major diameter has been reduced 0.010 in. to reflect the normal variations expected on hot-rolled bars due to the combined effect of bar diameter and out-of-round tolerances. Information on this increased tolerance is described in Note 3. The modified requirements are listed in Table 9.

NOTE 3—External threads that are to be used with threaded tapered plugs in expansion anchors are permitted to have somewhat increased pitch and major diameter tolerance. As bolt load is increased, the tendency for thread failure through nut diametrical expansion normally increases; however, in the case of threaded tapered plugs, increased load is accompanied by an increasing compression of the internal threads onto the external threads. This compensation for decreased major diameter is further augmented by the length of engagement which is longer than for standard nuts. Nuts to be used with threaded bars and threaded slotted bars shall be selected to provide adequate strength under these thread conditions.

8.3.2 External threads altered during the manufacturing process to facilitate product installation shall still maintain the 3 3/4 in. effective thread length. External threads at “head or exposed” end of bolt may have variable thread length for specific applications. Threads intended to be used to couple bolt sections together may be less than 3 3/4 in. effective thread length by agreement between supplier and purchaser for specific product applications.

8.3.3 Internal threads in threaded tapered plugs and threaded couplings shall be in accordance with ASME B 1.1 UNC 1B except that the threads shall be tapped oversize. This oversize is an increase in the pitch diameter of 0.003 in. to allow for handling damage on the external thread and dirt and long engagement in the internal thread. The maximum minor diameters are standard 1B for 1 1/2 to 3 diameter length of engagement. The modified requirements are listed in Table 9.

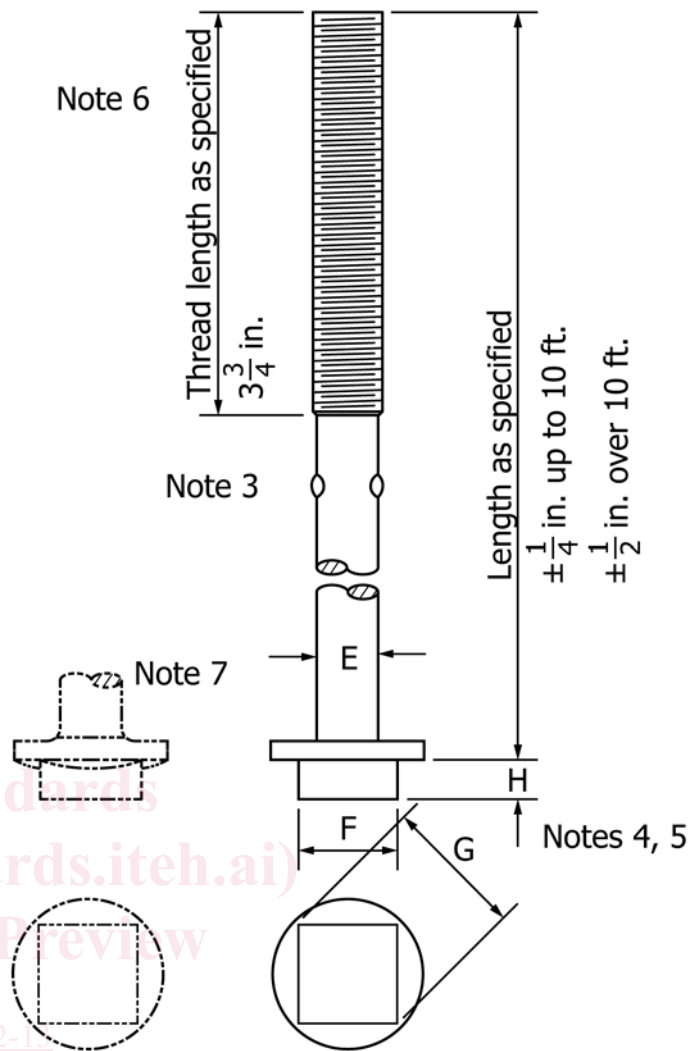

Nominal Bolt Size, 5/8 to 1 in. (Note 1)	
H—Head Height, min., in.	0.476
F—Head Across Flats, in.	1.088 to 1.125
G—Head Across Corners, in.	1.425 to 1.591
E—Body diameter is controlled by the roll threading operation.	

Note 1—When specified by the customer on the order or contract, the 5/8-in. diameter bolt may be supplied at:

- H—0.400
- F—0.906 to 0.938
- G—1.244 to 1.326

Note 2—When specified by the customer on the order or contract, a shoulder, collar, or swell equal to the body diameter of a 3/4-in. diameter bolt may be applied under the head of a 5/8-in. diameter bolt for a length of approximately 3/16 in.

Note 3—Pinched ears may be provided to support the expansion shell during installation.

Note 4—Bolt head may have depressed center.

Note 5—See Table 10 for head markings.

Note 6—See 8.3.1 for threads. Effective thread length shall be a minimum of 3 3/4-in. from any crimped location.

Note 7—Forging flash is permitted.

Note 8—External threads altered during the manufacturing process to facilitate product installation shall maintain the 3 3/4 in. effective thread length.

FIG. 1 Roof and Rock Bolts

8.3.4 Internal threads in nuts shall be tapped standard UNC 2B size in accordance with ASME B 1.1 or may be tapped oversize in accordance with 8.3.3 with agreement of producer and purchaser.

TABLE 9 Special Thread Requirements

External Threads		
Nominal Diameter, in.	Pitch Diameter, ^A in.	Major Diameter, ^B in.
5/8 -11	0.5531 to 0.5644	0.5952 to 0.6234
3/4 -10	0.6714 to 0.6832	0.7188 to 0.7482
7/8 -9	0.7884 to 0.8009	0.8423 to 0.8731
1-8	0.9037 to 0.9168	0.9655 to 0.9980
1 1/8 -7	1.0161 to 1.0300	1.0882 to 1.1228
1 1/4 -7	1.1409 to 1.1550	1.2132 to 1.2478
1 3/8 -6	1.2493 to 1.2643	1.3353 to 1.3726
1 1/2 -6	1.3742 to 1.3893	1.4603 to 1.4976

Internal Threads		
Nominal Diameter, in.	Pitch Diameter, ^C in.	Maximum Minor Diameter, in.
5/8 -11	0.5690 to 0.5797	0.551
3/4 -10	0.6880 to 0.6995	0.668
7/8 -9	0.8058 to 0.8181	0.783
1-8	0.9218 to 0.9350	0.896
1 1/8 -7	1.0352 to 1.0493	1.006
1 1/4 -7	1.1602 to 1.1746	1.131
1 3/8 -6	1.2697 to 1.2852	1.236
1 1/2 -6	1.3947 to 1.4105	1.361

^A Standard UNC 1A values except minimum reduced by 0.003 in.
^B Standard UNC 1A values except minimum reduced by 0.010 in.
^C Standard UNC 1B values increased by 0.003 in.

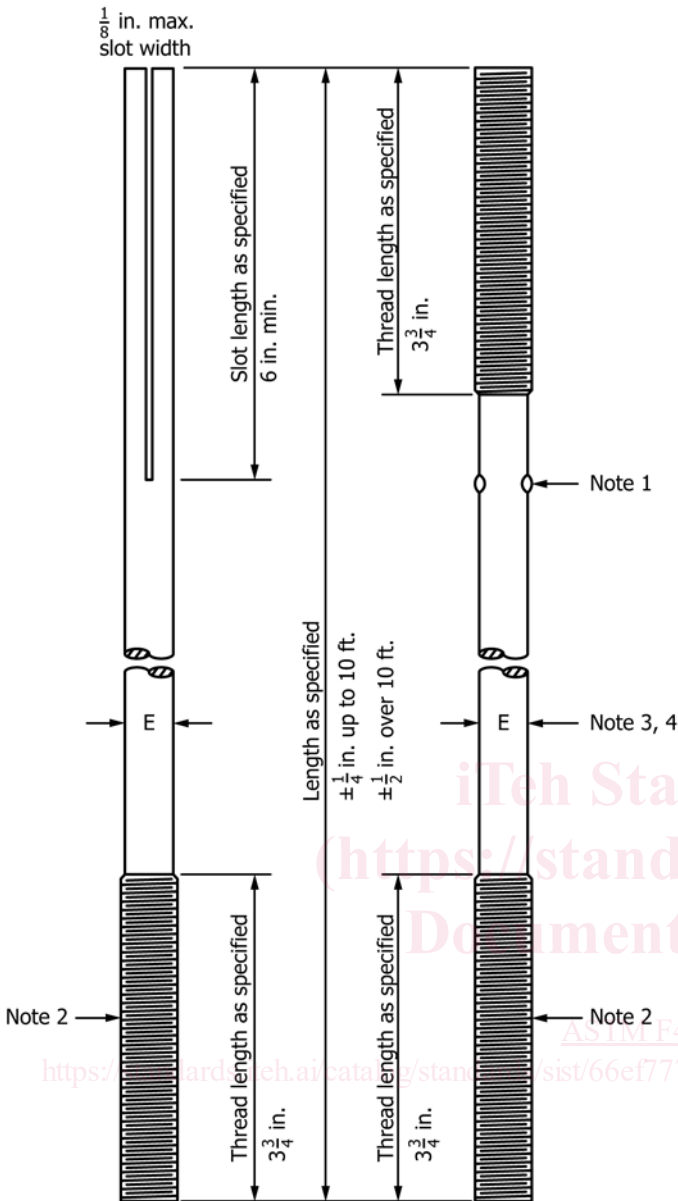

NOTE 1—Pinched ears may be provided to support the expansion shell during installation.
 NOTE 2—See 8.3.1 for threads. Effective thread length shall be minimum 3 3/4 in. from any crimped location.
 NOTE 3—E Body diameter is established by the method of threading.
 NOTE 4—Body diameter is controlled by the roll threading operation.
 NOTE 5—External threads altered during the manufacturing process to facilitate product installation shall maintain the 3 3/4 in. effective thread length.

FIG. 2 Threaded Bars and Slotted Threaded Bars

8.3.5 Gaging of threads shall be performed in accordance with System 21, ASME B 1.3M. Pitch diameter and thread crest diameter limits are specified in Table 9.

8.3.6 Threaded tapered plugs shall have a tapped length at least equal to one times the nominal bolt diameter with which they are to be used.

8.3.7 Threaded couplings shall have a tapped length at least equal to two times the nominal bolt diameter with which they are to be used.

8.4 Washer Requirements:

8.4.1 Round and square hardened washers shall be as shown in Fig. 3.

8.4.2 There are two types of hardened flat washers available. Type 1 is to be furnished unless otherwise specified.

8.4.2.1 Type 1 is either circular or square as shown in Fig. 3. It is designed for use with plate washers containing 1 3/8-in. holes, but may be used for all smaller hole sizes.

8.4.2.2 Type 2 is the hardened flat washer in accordance with Specification F436. It may be used only when sufficient clearance is available between the threaded-bar or threaded-rolled-bar body diameter near the head and the washer hole. This washer is not suitable for use with plate washers that contain holes that are more than 3/8 in. greater in diameter than the nominal bolt diameter.

8.5 Bearing and Header Plate Requirements:

8.5.1 Bearing and header plates may be of any thickness that successfully meets the test requirements in accordance with 10.4. The maximum hole size for use with bolts up to 3/4-in. nominal diameter shall be 1 3/8 in. except that hole size may be 1 1/2 in. when spherical washers or seats are used. Tolerance on hole diameter shall be -0, 1/8 in. Bearing plates for direct

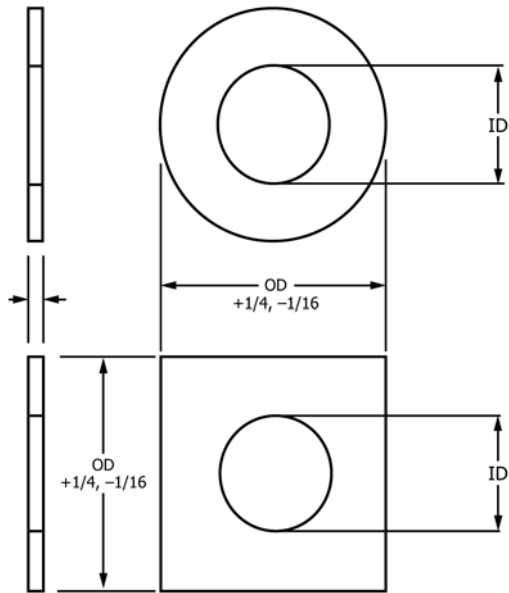

Bolt Size, in.	Nominal Outside Dimension, (O. D.) in.	Inside Diameter, (I. D.) in.	Thickness, in. (T)
5/8	2	1 1/16 to 27/32	0.122 to 0.177
3/4	2	1 3/16 to 31/32	0.122 to 0.177
7/8	2	1 5/16 to 1 5/32	0.132 to 0.177
1	2	1 1/8 to 1 9/32	0.132 to 0.177
1 1/8	2 1/2	1 1/4 to 1 13/32	0.132 to 0.177
1 1/4	2 1/2	1 3/8 to 1 17/32	0.132 to 0.177
1 1/2	3	1 5/8 to 1 29/32	0.132 to 0.177

FIG. 3 Round and Square Hardened Washer Type 1

bearing applications shall be 6 by 6 in. before the forming or shaping process with tolerances for length and width of $\pm 1/8$ in. Larger bearing plates may be furnished, dimensions and tolerances to be by agreement between the producer and the purchaser. Smaller bearing plates may be used in conjunction with steel channels, with other accessories, or in hard rock areas by agreement between the producer and the purchaser. Header plates are typically 6 in. wide by 16 to 18 in. long, or any other shape with an equivalent area.

8.5.2 Bearing and header plates used with frictional anchorage devices shall meet the test requirements in 10.4. The hole sizes and tolerances shall be set by the manufacturer of the frictional anchorage device.

8.6 General Components:

8.6.1 Dimensions not otherwise specified for cable head assemblies, tapered wedges, expansion shells, threaded tapered plugs, beveled washers, spherical washers, threaded couplings, and extensions shall be by agreement between the producer and the purchaser.

8.7 Nuts:

8.7.1 Nuts shall be hex, heavy hex, square, or heavy square in accordance with ASME B 18.2.2. Unless otherwise specified, the heavy series shall be supplied.

8.8 Surface Configuration on Formable Anchor Bars or Bolts:

8.8.1 Surface configurations on steel bars or bolts to be used with polyethylenes, as specified in 5.14.1.1, formable anchorage devices.

8.8.1.1 Three pitch modified reverse buttress form as described in Fig. 4.

8.9 Dimensions of Formable Anchor Tubes:

8.9.1 Dimensions of formable anchor tubes made from materials conforming to 5.14.1.

8.9.1.1 The wall thickness of the formable anchor tube shall be as specified by the manufacturer ± 0.015 in.

8.9.1.2 The weight per inch of formable anchor tubes shall be as specified by the manufacturer $\pm 8\%$.

8.9.1.3 The length of formable anchor tubes shall be as specified by the manufacturer ± 0.250 in.

NOTE 4—Barrier plugs may be used with the formable anchor tubes to separate grouted or chemically anchored segments of the bars or bolts from formable anchorage devices. In such cases, the barrier plug shall be considered as a portion of the tube length.

8.10 Dimensions of Expandable Rock Bolts:

8.10.1 Dimensions of expandable rock bolts shall be specified by the manufacturer. Nominal length dimensions shall be maintained between $+1/2$ in, -1 in. as agreed upon between manufacturer and purchaser.

8.10.2 Manufacturer shall specify original expandable rock bolt tubing diameter in the specific product certification documents.

9. Number of Tests and Retests

9.1 Bars—Two tension tests shall be made from each heat for each nominal diameter of bars unless the finished material from a heat is less than 30 tons, when one tension test will be sufficient. Certification by the bar supplier that the requirements of Table 4 have been met is an acceptable substitute for these bar tension tests.

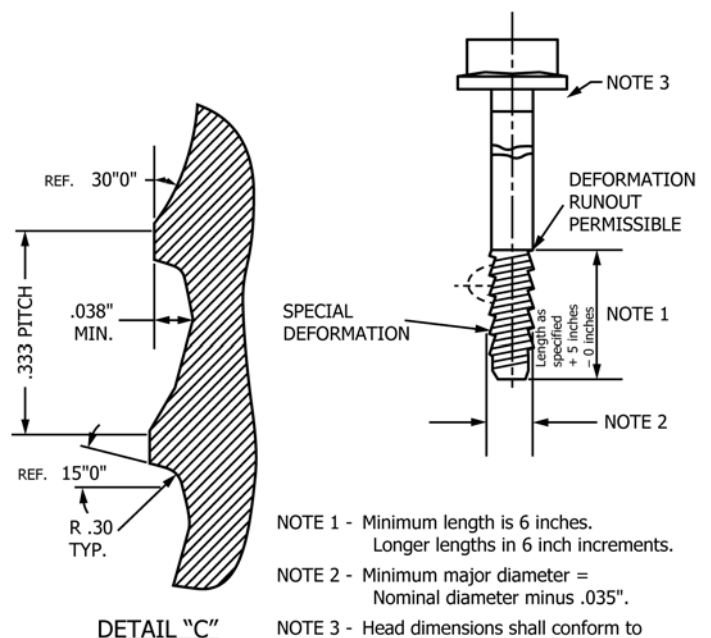

FIG. 4 Three-Pitch Modified Reverse Buttress Bolt

9.2 *Bolts, Threaded Bars, Threaded Slotted Bars, Bearing and Header Plates, Frictional Anchorage Devices, Expandable Rock Bolts, and All Types of Washers*—The requirements of this specification shall be met in continuous mass production. The manufacturer shall make sample inspections and tests to ensure that the product represented by the test samples conforms to the specified requirements. The manufacturer shall select and test a minimum of two bolts, threaded bars, threaded slotted bars, bearing and header plates, frictional anchorage devices, expandable rock bolts, and washers from each discontinuous turn or each 24 h of continuous production.

9.3 Improper machining or preparation of test specimens may give erroneous results. Improperly machined specimens shall be discarded and other specimens substituted.

9.4 If any test specimen fails to meet the specification requirements because of failure of testing equipment or improper specimen preparation, it may be discarded and another specimen taken.

10. Test Methods

10.1 Test bars used for the manufacture of bolts and threaded and threaded slotted bars for yield point, tensile strength, and elongation in accordance with the Determination of Tensile Properties Section of Test Methods and Definitions **A370**.

10.2 Tension test bolts and threaded bars in accordance with the Wedge Tension Testing of Full Size Product paragraph of Test Methods **F606** for tensile strength. Obtain the yield point in the course of this test by the Drop of the Beam or Halt of the Pointer Method as described in the paragraphs on Tension Testing of Machined Test Specimens of Test Methods **F606**.

10.2.1 If the length of the bolt or threaded bar exceeds the length that can be accommodated by the testing machine, then cut the head with a portion of the body in the case of bolts, and the thread with a portion of the body, from the bolt or threaded bar and test each separately.

10.2.1.1 Test the section containing the threads for yield point and breaking load by using the nut intended for use on the threaded portion and by gripping the bolt body. Failure may not occur by stripping of threads.

10.2.1.2 Test the section containing the bolt head with a 10° wedge under the head and by gripping the body. For smooth bars, it is permissible to increase the hole clearance in the wedge plate to two times the clearance specified in Test Methods **F606** to accommodate collars or swell under the bolt head. For deformed bars, it is permissible to increase the hole clearance of the wedge plate to four times the clearance specified in Test Methods **F606**.

10.2.1.3 Test bolts containing surface configurations by gripping a section of the surface configuration and the body of the bolt.

10.3 Threaded Slotted Bars:

10.3.1 Threaded slotted bars from which material has not been removed during the slotting operation (forged split-end bars) need not be tested on the slotted end.

10.3.2 Test threaded slotted bars from which material has been removed when making the slot at the slotted ends. If the

length of the bar exceeds the length that can be accommodated by the testing machine, then the excess length may be cut off and discarded.

10.3.2.1 Perform the test of the slotted end by first tack welding the two sides together at the extreme end of the bar. Grip both ends of this test bar and contain at least 1 in. of slot in the tested portion between the grips.

10.4 Tests of Bearing and Header Plates:

10.4.1 Locate the bearing plate sample centrally on a steel test plate containing a hole 4 in. in diameter. The steel test plate shall be the dimensions shown in **Fig. 5**. Exert a load on the bearing plate by either (1) assembling bolt, threaded rod and nut, or fixture through the bearing plate, placing the plate assembly on the crosshead of a testing machine and gripping the bolt, rod, or fixture and pulling down with the upper platen, or (2) pushing down with a punch having a diameter of approximately 1.75 in. or equal to the fixture's outside diameter, whichever is greater, mounted underneath the upper platen onto the plate assembly placed on the lower platen of the testing machine. If it is to be included in the actual installation, include in the test assembly a hardened washer of the type defined in this specification. Apply an initial preload of 6000 lbf and then place a measuring device accurate to 0.001 in. so as to be capable of measuring the axial movement of the bolt head or ram. Set the measuring device to zero after application of the 6000-lbf preload. Increase the load to 15 000 lbf and read the axial movement, defined as deflection, from the measuring device. The maximum permissible deflection between the 6000 and 15 000-lbf loads is 0.120 in. Continue the application of load until the grade rating of the plate is reached and again read the axial movement from the measuring device. The maximum permissible deflection between 6000 lbf and the grade rating is 0.250 in.

10.4.2 Test large bearing plates (maximum dimension greater than 7 in. and header plates for span performance in accordance with **10.4.2.1**.

10.4.2.1 Locate the plate sample centrally on a steel test plate containing a clear span of 6 in. The steel test plate shall be the dimensions shown in **Fig. 6**. Exert a load on the plate by either (1) assembling bolt, threaded rod and nut, or fixture through the plate, placing the plate assembly on the crosshead of a testing machine and gripping the bolt, rod, or fixture and pulling down with the upper platen, or (2) pushing down with a punch having a diameter of approximately 1.75 in. or equal to the fixture's outside diameter, whichever is greater, mounted underneath the upper platen of the testing machine. If it is to be included in the actual installation, include in the test assembly a hardened washer of the type defined in this specification. Apply an initial preload of 1000 lbf and then place a measuring device accurate to 0.001 in. so as to be capable of measuring the axial movement of the bolt head or ram. Set the measuring device to zero after application of the 1000-lbf preload. Increase the load to 5000 lbf and read the axial movement, defined as deflection, from the measuring device. The maximum permissible deflection between the 1000 and 5000-lbf loads is 0.250 in.

The test described in **10.4.2.1** shall be performed to establish product performance whenever manufacturing process,

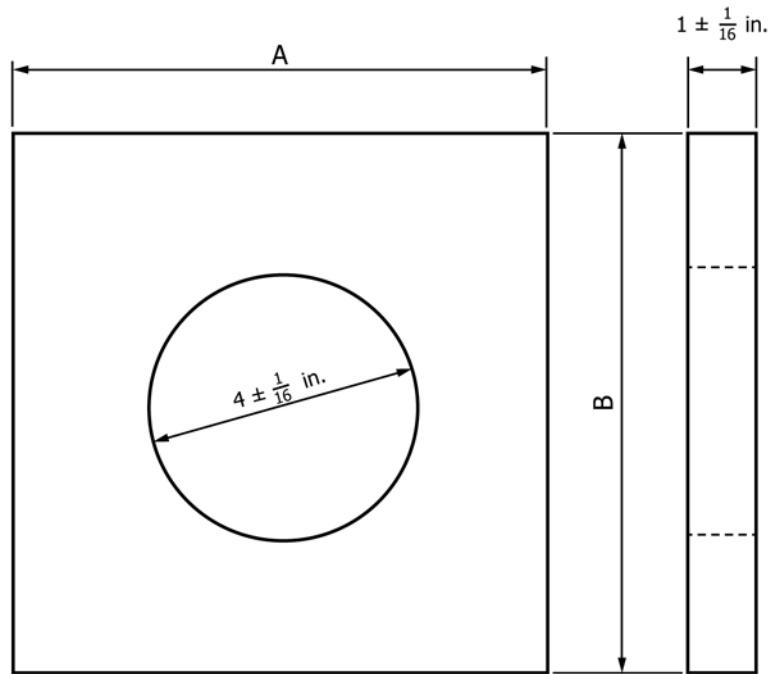

NOTE 1—A 36 or similar steel.

NOTE 2—Hole to be centrally located.

NOTE 3—Dimensions A and B shall each be a minimum of 2 in. longer than the comparable dimensions of the bearing or header plates to be tested.

FIG. 5 Bearing Plate Test Plate

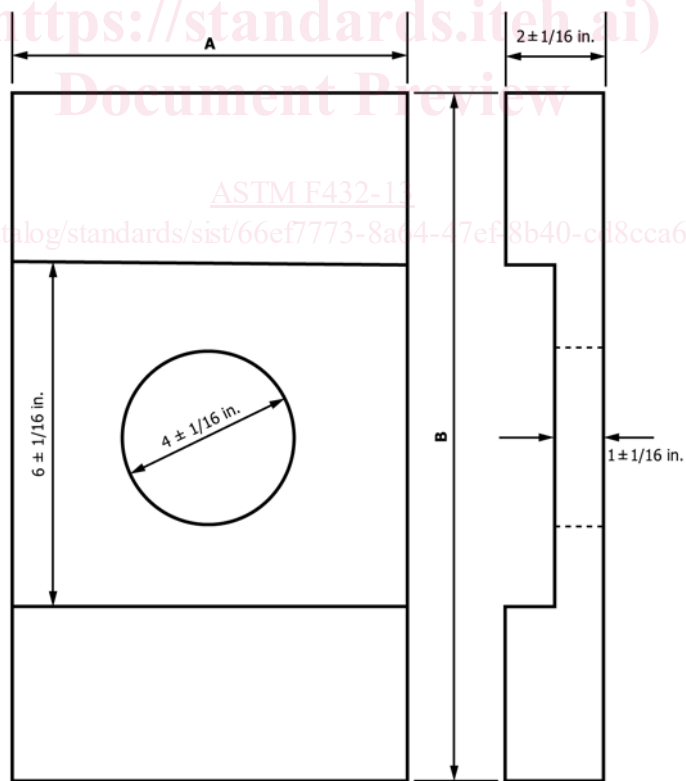

NOTE 1—A36 or similar steel.

NOTE 2—Slot to be centrally located.

NOTE 3—Dimensions A and B shall each be a minimum of 2 in. longer than the comparable dimensions of the bearing or header plates to be tested.

FIG. 6 Span Test Plate