



Designation: **G195—08 G195 – 13**

Standard Guide for Conducting Wear Tests Using a Rotary Platform, Double- Head Platform Abraser¹

This standard is issued under the fixed designation G195; the number immediately following the designation indicates the year of original adoption or, in the case of revision, the year of last revision. A number in parentheses indicates the year of last reapproval. A superscript epsilon (ϵ) indicates an editorial change since the last revision or reapproval.

1. Scope

1.1 This guide covers and is intended to assist in establishing procedures for conducting wear tests of rigid or flexible materials utilizing the rotary platform, double-head abraser (RPDH)-platform abraser.

1.2 The values stated in SI units are to be regarded as standard. No other units of measurement are included in this standard.

1.2.1 *Exception*—English Inch-pound units are used when stating rotational speed and determining coating thickness.

1.3 *This standard does not purport to address all of the safety concerns, if any, associated with its use. It is the responsibility of the user of this standard to establish appropriate safety and health practices and determine the applicability of regulatory limitations prior to use.*

2. Referenced Documents

2.1 *ASTM Standards:*²

[C501 Test Method for Relative Resistance to Wear of Unglazed Ceramic Tile by the Taber Abraser](#)

[C1353 Test Method for Abrasion Resistance of Dimension Stone Subjected to Foot Traffic Using a Rotary Platform, Double-Head Abraser](#)

[D1044 Test Method for Resistance of Transparent Plastics to Surface Abrasion](#)

[D3389 Test Method for Coated Fabrics Abrasion Resistance \(Rotary Platform Abrader\)](#)

[D3451 Guide for Testing Coating Powders and Powder Coatings](#)

[D3730 Guide for Testing High-Performance Interior Architectural Wall Coatings](#)

[D3884 Test Method for Abrasion Resistance of Textile Fabrics \(Rotary Platform, Double-Head Method\)](#)

[D4060 Test Method for Abrasion Resistance of Organic Coatings by the Taber Abraser](#)

[D4685 Test Method for Pile Fabric Abrasion](#)

[D4712 Guide for Testing Industrial Water-Reducible Coatings](#)

[D5034 Test Method for Breaking Strength and Elongation of Textile Fabrics \(Grab Test\)](#)

[D5035 Test Method for Breaking Force and Elongation of Textile Fabrics \(Strip Method\)](#)

[D5144 Guide for Use of Protective Coating Standards in Nuclear Power Plants](#)

[D5146 Guide to Testing Solvent-Borne Architectural Coatings](#)

[D5324 Guide for Testing Water-Borne Architectural Coatings](#)

[D6037 Test Methods for Dry Abrasion Mar Resistance of High Gloss Coatings](#)

[D7255 Test Method for Abrasion Resistance of Leather \(Rotary Platform, Double-Head Method\)](#)

[F362 Test Method for Determining the Erasability of Inked Ribbons](#)

[F510 Test Method for Resistance to Abrasion of Resilient Floor Coverings Using an Abrader with a Grit Feed Method](#)

[F1344 Specification for Rubber Floor Tile](#)

[F1478 Test Method for Determination of Abrasion Resistance of Images Produced from Copiers and Printers \(Taber Method\)](#)

[F1978 Test Method for Measuring Abrasion Resistance of Metallic Thermal Spray Coatings by Using the Taber Abraser](#)

[G40 Terminology Relating to Wear and Erosion](#)

¹ This guide is under the jurisdiction of ASTM Committee G02 on Wear and Erosion and is the direct responsibility of Subcommittee G02.30 on Abrasive Wear. Current edition approved May 1, 2008; July 1, 2013. Published May 2008; July 2013. Originally approved in 2008. Last previous edition approved in 2008 as G195–08. DOI: 10.1520/G0195-08.10.1520/G0195-13.

² For referenced ASTM standards, visit the ASTM website, www.astm.org, or contact ASTM Customer Service at service@astm.org. For *Annual Book of ASTM Standards* volume information, refer to the standard's Document Summary page on the ASTM website.

3. Terminology

3.1 Definitions of Terms Specific to This Standard:

3.1.1 *abraser*—wear testing instrument to evaluate abrasion resistance, also referred to as an abrader.

3.1.2 *abrasion cycle*—in abrasion testing, one or more movements of the abradant across a material surface, or the material surface across the abradant, that permits a return to its starting position. In the case of the rotary platform abraser test method, it consists of one complete rotation of the specimen-turnstile specimen platform.

3.1.3 *resurface*—procedure of cleaning and refreshing the running surface of an abrasive wheel prior to use ~~in or during~~ testing.

3.2 For definitions of other wear terms used in this ~~test method, guide,~~ refer to Terminology **G40**.

4. Summary of Practice

4.1 A specimen is abraded using rotary rubbing action under controlled conditions of pressure and abrasive action. The test specimen, mounted on a turntable platform, turns on a vertical axis, against the sliding rotation of two abrading wheels. One abrading wheel rubs the specimen outward toward the periphery and the other, inward toward the ~~center-center~~ while a vacuum system removes wear debris generated during the test. The resulting abrasion marks form a pattern of crossed arcs over an area of approximately 30 cm². Resistance to abrasion is evaluated by various means which are described in Section **12**.

5. Significance and Use

5.1 This test guide provides a means to quantify the abrasion resistance of material surfaces, and may be related to end-use performance, or used to comparatively rank material performance, or both. The resistance of material surfaces to abrasion, as measured on a testing machine in the laboratory, is generally only one of several factors contributing to wear performance as experienced in the actual use of the material. Other factors may need to be considered in any calculation of predicted life from specific abrasion data.

5.2 The resistance of material surfaces to abrasion may be affected by factors including test conditions; type of abradant; pressure between the specimen and abradant; mounting or tension of the specimen; and type, kind, or amount of finishing materials.

5.3 Abrasion tests utilizing the rotary ~~platform, double head platform~~ abraser may be subject to variation due to changes in the abradant during the course of specific tests. Depending on abradant type and test specimen, the abrading wheel surface may change (i.e. become clogged) due to the pick-up of finishing or other materials from test specimens. To reduce this variation, the abrading wheels should be resurfaced at regularly defined intervals. See **Appendix X2**.

5.4 The measurement of the relative amount of abrasion may be affected by the method of evaluation and influenced by the judgment of the operator.

6. Apparatus

6.1 *Rotary Platform, Double-Head (RPDH)-Platform Abraser*, consisting of the elements described in **6.1.1** to **6.1.5** (see **Fig. 1**). Also referred to as a rotary platform, double head (RPDH) abraser.

6.1.1 A turntable specimen platform, which is removable, that includes a rubber pad, clamp plate, centrally located threaded post and nut. When testing flexible specimens, the specimen platform will also include a clamping ring. The turntable shall be motor driven, and mounted so as to produce a circular surface travel of a flat specimen in the plane of its surface. The specimen platform should rotate with no visible wobble. This can be checked with a dial indicator at the top outer edge of the platform to make sure it runs true within 0.5 mm.

6.1.2 A motor capable of rotating the turntable platform at a speed of either 72 ± 2 rpm or 60 ± 2 rpm.

6.1.3 A pair of pivoted arms to which the abrasive wheels and accessory weights or counterweights are attached.

6.1.4 A vacuum suction system and vacuum pickup nozzle to remove debris and abrasive particles from the specimen surface during testing. The vacuum suction force shall be ~~137 millibar (55 in. 13.7 kPa (139.7 cm of water column)~~ or greater, as measured by a vacuum gage at the vacuum pick-up nozzle port. The height of the vacuum pickup nozzle shall be adjustable, and the nozzle will have two 8 mm ~~openings—openings~~ except in the case of **D1044** when 11 mm openings are specified. One opening shall be positioned between the two wheels and over the wear path and the other placed diametrically opposite, with the distance between the axes of the two openings 76.0 ± 1.0 mm.

6.1.5 A counter to record the number of abrasion cycles (revolutions) made by the turntable platform.

6.2 *Abrasive Wheels*,³ which are attached to the free end of the pivoted arms and are able to rotate freely about horizontal spindles.

6.2.1 The wheels shall be 12.7 ± 0.3 mm thick and have an external diameter of 51.9 ± 0.5 mm when new, and in no case less than 44.4 mm. The abrasive wheels are either resilient or vitrified based, with both types of wheels consisting of hard particles

³ The sole source of supply of the apparatus known to the committee at this time is Taber Industries, 455 Bryant Street, North Tonawanda, NY 14120. If you are aware of alternative suppliers, please provide this information to ASTM International Headquarters. Your comments will receive careful consideration at a meeting of the responsible technical committee,¹ which you may attend.

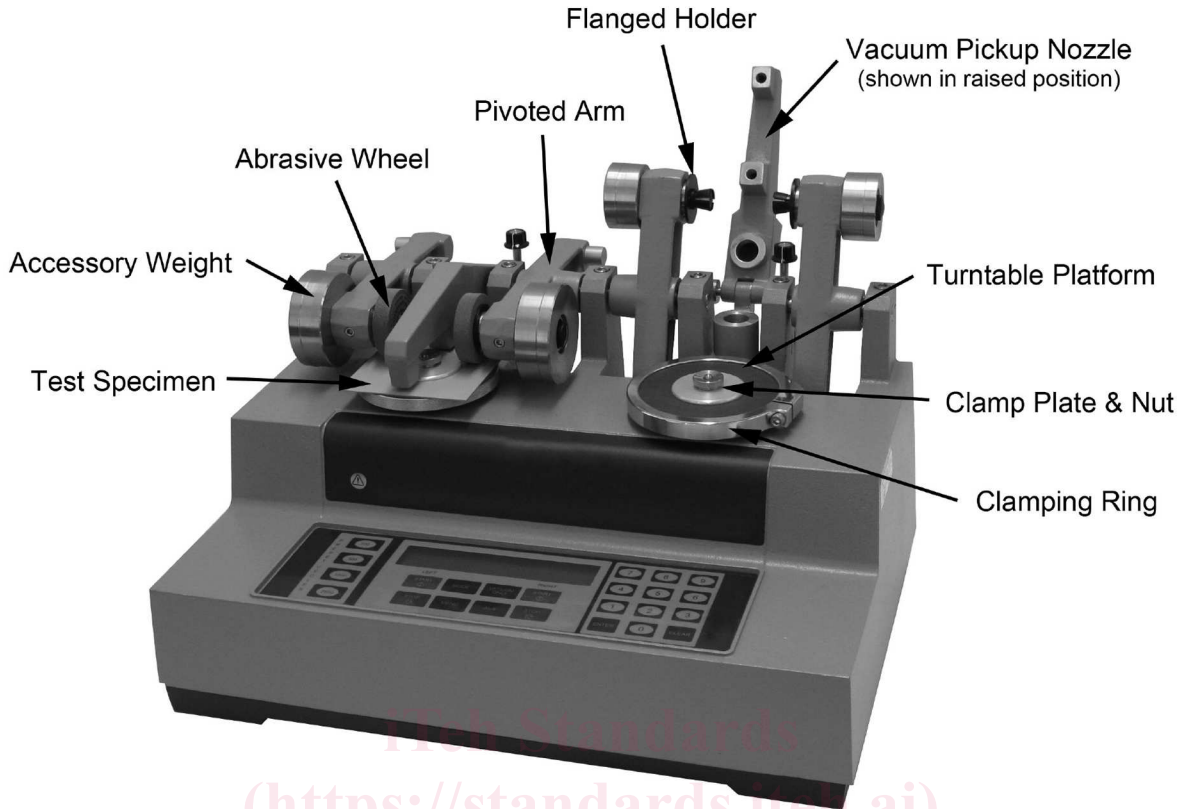

Note: Vacuum Suction System not shown

FIG. 1 Rotary Platform, Double-Head (RPDH) Platform Abraser

ASTM G195-13

<https://standards.iteh.ai/catalog/standards/sist/d15d26eb-2e7f-4fb9-8f66-488db564a1b3/astm-g195-13>

embedded in a binder material and manufactured in different grades of abrasive quality. Other types of wheels, which do not include hard particles embedded in a binder material, may also be used (see X1.4).

6.2.2 The internal faces of the abrasive wheels shall be 52.4 ± 1.0 mm apart and the hypothetical line through the two spindles shall be 19.05 ± 0.3 mm away from the central axis of the turntable (see Fig. 2). The wheels should be spaced equally on both sides from the wheel-mounting flange to the center of the specimen holder. The distance from the inside of the wheel mounting flange to the center of the specimen holder shall be 38.9 ± 0.5 mm.

6.2.3 When resting on the specimen, the wheels will have a peripheral engagement with the surface of the specimen, the direction of travel of the periphery of the wheels and of the specimen at the contacting portions being at acute angles, and the angles of travel of one wheel periphery being opposite to that of the other. Motion of the abrasive wheels, in opposite directions, is provided by rotation of the specimen and the associated friction therefrom.

6.2.4 Prior to testing, ensure the expiration date has not passed for resilient wheels.

6.3 *Accessory Weights*, can be attached to the pivoted arms to increase or decrease the force at which the wheel is pressed against the specimen, exclusive of the mass of the wheel itself. Commonly used masses are 250 ± 1 g, 500 ± 1 g, and 1000 ± 1 g. Accessory weight references are per arm (not combined), and include the mass of the pivoted arm.

6.4 Auxiliary Apparatus:

6.4.1 Refacing disc, for resurfacing of resilient wheels. The refacing disc shall be 150 grit silicon carbide coated abrasive product, approximately 102 mm diameter with a 7-mm center hole, such as type S-11 or equivalent.

6.4.2 Refacing stone (for example, fine side of ST-11³), for resurfacing of CS-10F³ resilient wheels when testing transparent materials.

6.4.3 Wheel refacer, with a diamond tool for resurfacing vitrified wheels or correcting out of round wheels.

6.4.4 A soft bristle brush, to remove loose particles from the surface of the specimen after testing.

6.4.5 Specimen mounting cards, approximately 108 mm round or square with a 7-mm center hole and one side coated with pressure sensitive adhesive to secure specimens.

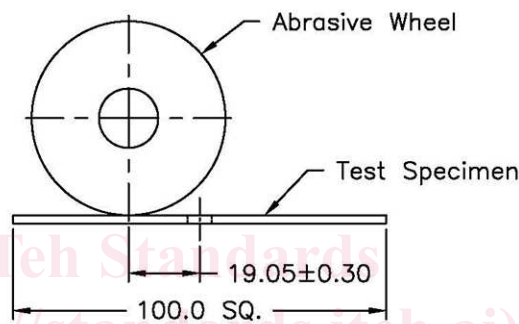
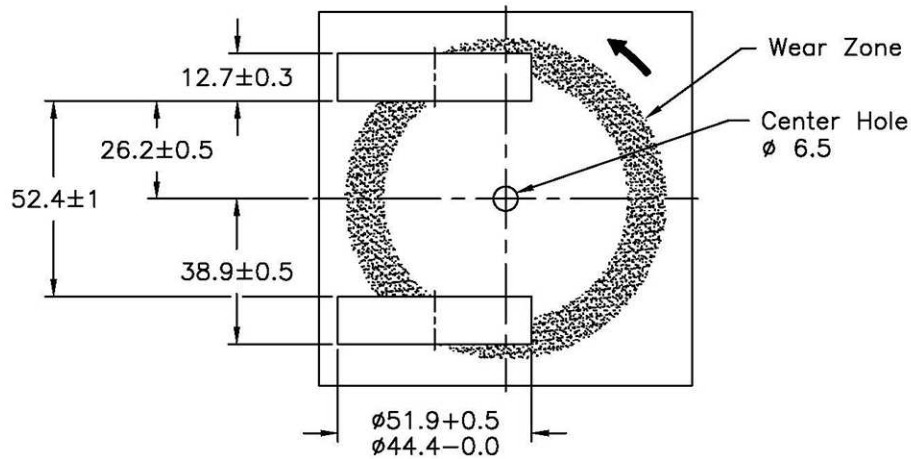

dimensions in millimeters
FIG. 2 Central Axis of the Turntable

ASTM G195-13

7. Specimen Preparation

7.1 *Materials*—It is the intent of this test guide to allow for the abrasion testing of any material form, provided it is essentially flat. The field of application is varied and includes solid materials, metals, plastics, coated surfaces (for example, paint, lacquer, electroplated), textiles (ranging from sheer silks to heavy upholstery), leather, rubber, linoleum, and the rest.

7.1.1 Accepted industry practice should be employed for specimen preparation. Specific recommendations for specimen preparation may be available from the ASTM subcommittee responsible for that material. Selection and use should be agreed upon between the interested parties.

7.2 *Specimen Thickness*—The standard material thickness that can be evaluated with the rotary platform abramer is 6.35 mm or less.

NOTE 1—For materials thicker than 6.35 mm but less than 12.7 mm, an extension nut such as type S-21³ or equivalent may be used. Alternatively, an arm height extension kit³ will permit testing of specimens up to 40 mm.

7.3 *Specimen Size*—The width of the resulting wear path is 12.7 mm, and is located 31.75 mm from the center of the specimen. The size of the specimen may vary depending on the material being evaluated:

7.3.1 For most rigid materials, a sample approximately 100 mm square is recommended with a 6.356.5 mm diameter center hole.

7.3.2 Flexible specimens are typically circular and require the use of the clamp ring. If a mounting card is used, the specimen should be approximately 105 mm in diameter with a 6.356.5 mm diameter center hole. If no mounting card is used, an approximately 135 mm specimen is required such that the clamp ring will grip overlapped material. The specimen should include a 6.356.5 mm diameter hole in the center of the specimen. A sample cutter or die has been found useful for preparing flexible specimens.

7.4 *Mounting Card*—Certain flexible specimens may wrinkle or shift during testing. To prevent this, a mounting card with a pressure sensitive adhesive may be used. Prior to adhering, clean the back of the specimen with a soft bristle brush to remove any loose debris. Position the specimen on the card such that the specimen is free of folds, creases, or wrinkles and the center holes align.

8. Preparation and Set-Up of Apparatus

8.1 The following set-up parameters are dependent on the type of material being evaluated and shall be agreed upon by the interested parties. See [Appendix X1](#) for guidance.

8.1.1 *Selection of Wheels*—Abrasive wheels manufactured in different grades are commercially available.³

8.2 *Vacuum Suction*—The vacuum suction force should be adjusted to lift the abraded particles, but not lift the specimen.

8.3 *Vacuum Pickup Nozzle*—The gap between the vacuum pickup nozzle and the specimen surface should be adjusted after the specimen has been mounted. A gap of 7 ± 1 mm has been found to be sufficient for most materials. On certain rigid materials, a setting of 3 mm has been found to be more effective.

8.1 *Abrading Wheel Loading*—The mass selected should permit a minimum number of abrasion cycles (i.e. 150) before the end of the test occurs. A mass of 500 g or 1000 g applied per wheel has been found to be sufficient for materials that are considered to be durable. A mass of 250 g or 500 g applied per wheel has been found to be sufficient following set-up parameters are dependent on the type of material being evaluated and shall be agreed upon by the interested parties. See [Appendix X1](#) for less durable materials: guidance.

8.1.1 *Selection of Wheels*—Abrasive wheels manufactured in different grades are commercially available.³

8.1.2 *Vacuum Suction*—The vacuum suction force should be adjusted to lift the abraded particles, but not lift the specimen.

8.1.3 *Vacuum Pickup Nozzle*—The gap between the vacuum pickup nozzle and the specimen surface should be adjusted after the specimen has been mounted. A gap of 7 ± 1 mm has been found to be sufficient for most materials. On certain rigid materials, a setting of 3 ± 1 mm has been found to be more effective.

8.1.4 *Abrading Wheel Loading*—The mass selected should permit a minimum number of abrasion cycles (i.e. 150) before the end of the test occurs. A mass of 500 g or 1000 g applied per wheel has been found to be sufficient for materials that are considered to be durable. A mass of 250 g or 500 g applied per wheel has been found to be sufficient for less durable materials.

9. Standardization of Abrasive Wheels

9.1 *Preparation of Resilient Abrading Wheels*—To ensure that the abrading function of the wheels is maintained at a constant level, prepare the resilient wheels according to the manufacturer's recommendations. See [Appendix X2](#).

9.2 *Preparation of Vitrified Abrading Wheels*—Vitrified wheels do not require resurfacing unless the abrading surface becomes clogged, chipped or out of round. A wheel refacer should be used to correct any of these conditions.

10. Conditioning

10.1 Prior to testing, condition all specimens according to established procedures specific to the material being evaluated or as agreed upon by the interested parties.

11. Procedure

11.1 Mount the wheels on their respective flanged holders, taking care not to handle them by their abrasive surfaces. Prior to testing, ensure that the wheels have been resurfaced according to Section 9 if necessary.

11.2 Depending on the type of evaluation criteria being utilized (see Section 12), it may be necessary to measure and record specific parameters of the unabraded specimen prior to conducting the test:

11.2.1 Mass loss method, weigh the specimen to the nearest mg. If using a mounting card, weigh after the specimen has been affixed to the card and conditioned in the standard testing environment.

11.2.2 Wear cycles per mil or depth of wear method, use a thickness gage or other appropriate device to measure the specimen thickness on four points along the path to be abraded, approximately 38 mm from the center hole and 90° apart. Calculate the average of the readings.

11.3 *Mounting of Specimen*—Place the test specimen face up over the rubber mat on the turntable platform, unless otherwise specified. If the turntable platform was previously removed, ensure it is properly replaced on the motor drive shaft of the abramer prior to testing.

11.3.1 For rigid materials, secure the clamp plate and nut in place to hold the specimen.

11.3.2 For textile and other flexible materials, lightly secure the clamp plate and nut in place to hold the center of the specimen. Place the clamping ring over the turntable platform with the screw of the clamping ring at one end of the warp. Partially tighten the screw, and push the clamping ring half way down the edge of the turntable platform. Draw the specimen taut over the turntable platform by pulling on the corners and edges of the specimen. Tighten the clamping ring $\frac{1}{4}$ turn and push the ring all the way ~~down~~ ~~over,~~ ~~down,~~ thus putting tension on the specimen as it is secured on holder. Finish tightening the nut and clamping ring. Avoid buckling the fabric when tightening. Trim off excess fabric around the edges. It is recommended not to remove the specimen from the specimen holder until the entire test is completed.

11.4 *Abrading Wheel Loading*—Select the mass to be used and affix it to the rotary ~~platform,~~ ~~double head platform~~ abramer (see [8.4.8.1.4](#)).

11.5 *Number of Abrasion Cycles*—The number of rotations of the turntable platform to which the specimen is to be subjected will depend on the type of material being tested, the type of abrading wheels used, the abrading wheel loading, and the type of test employed. The number of cycles should be predetermined by mutual agreement by the interested parties.

11.6 Lower the abrading heads carefully onto the surface of the specimen.

11.7 *Cleaning of Specimen*—The RPDH-vacuum system is used to clean the specimen of debris and abrasive particles during the test. Position the nozzle above the specimen surface as determined in [8:38.1.3](#) and adjust the vacuum suction as outlined in [8:28.1.2](#). For some materials, it may be necessary to use a soft bristle brush to clean the specimen surface at set intervals during the test.

11.8 Start the RPDH-rotary platform abraser and subject the test specimen to abrasion for the specified number of cycles as established in [11.5](#).

11.8.1 Depending on the type of evaluation criteria being utilized (see Section [12](#)), the rate of wear may be calculated or plotted on a graph, or both. If required, take measurements periodically during testing with the frequency to be determined by the interested parties.

NOTE 2—In calculating Wear Index (see [12.3](#)) or Wear Cycles Per Mil (see [12.4](#)) of surface coatings and similar materials, it may be advisable to discard the final reading if results are affected by abrasion of the exposed substrate.

11.8.2 If cycles to a specific end point is used as the evaluation criteria (see [12.7](#)), it may be necessary to stop the instrument at intervals during the test to examine the test specimen.

11.9 *Resurfacing of Wheels*—Due to uneven wear and clogging of the surface crevices with abraded debris (for example, fiber particles, finishing materials, and the like), the abrading wheels should be resurfaced at established intervals during tests, the frequency depending on the type of material being tested and the type of wheel used (see [Appendix X2](#)).

11.10 *Cleaning of Specimen After Test*—After the test is complete, a soft bristle brush may be used to remove any loose debris and abraded material remaining on the test specimen.

11.11 After testing, raise the abrader arms and vacuum nozzle then remove the specimen for evaluation. If desired, the turntable platform may be removed from the abraser by lifting straight up. This will permit a closer inspection of the specimen prior to removal from the turntable platform. Use a soft bristle brush or cloth to clean the rubber pad after each test.

12. Calculation or Interpretation of Results

NOTE 3—This guide does not recommend any specific interpretation of results but does provide procedures commonly used by industry.

12.1 After the specimens have been abraded to the set number of cycles or other specified endpoint, evaluate as directed in [12.2-12.10](#) as appropriate. If a mounting card was used and any evaluation technique described in [12.8-12.10](#) is employed, carefully remove the specimen from the mounting card.

12.2 *Mass Loss*—Change in mass caused by abrasion. Weigh the specimen after abrasion and compute mass loss, L , of the test specimen as follows:

$$L = A - B \quad (1)$$

where:

A = mass of test specimen before abrasion, mg, and
 B = mass of test specimen after abrasion, mg.

12.3 *Wear Index*—Loss in mass in milligrams per thousand cycles of abrasion. Weigh the specimen after abrasion and compute the wear index, I , of a test specimen as follows:

$$I = \frac{(A - B) 1000}{C} \quad (2)$$

where:

A = mass of test specimen before abrasion, mg,
 B = mass of test specimen after abrasion, mg, and
 C = number of cycles of abrasion recorded.

12.4 *Wear Cycles per mil (0.001 in.)*—Abrasion cycles required to wear through a coating of a known thickness. Compute the wear cycles per mil, W , of the test specimen as follows:

$$W = \frac{D}{T} \quad (3)$$

where:

D = number of cycles of abrasion required to wear coating through to substrate, and
 T = thickness of coating, mils.