



# SLOVENSKI STANDARD

## SIST EN 12881-1:2006

01-marec-2006

---

BUdfUj YnU\_cbljbi ]fb]`fUbgdcfhE`HfU\_cj ]`fU b]`fUbgdcfhf`Yj `E`  
DcYUfbcj Ufbcgfb]`dfYg\_i g]`E`%`XY.`DfYg\_i g]`g`dfcdUbg\_]a `[cf]`b]\_ca

Conveyor belts - Fire simulation flammability testing - Part 1: Propane burner tests

Fördergurte - Brandtechnische Prüfungen - Teil 1: Prüfungen mit dem Propanbrenner

Courroies transporteuses - Essais simulation d'inflammation - Partie 1: Essais avec  
bruleur propane

[SIST EN 12881-1:2006](https://standards.iteh.ai/catalog/standards/sist/bbe52616-5dc8-41ad-88e6-929b49163077/sist-en-12881-1-2006)

[https://standards.iteh.ai/catalog/standards/sist/bbe52616-5dc8-41ad-88e6-](https://standards.iteh.ai/catalog/standards/sist/bbe52616-5dc8-41ad-88e6-929b49163077/sist-en-12881-1-2006)

[929b49163077/sist-en-12881-1-2006](https://standards.iteh.ai/catalog/standards/sist/bbe52616-5dc8-41ad-88e6-929b49163077/sist-en-12881-1-2006)

Ta slovenski standard je istoveten z: **EN 12881-1:2005**

---

### ICS:

13.220.40	Sposobnost vžiga in obnašanje materialov in proizvodov pri gorenju	Ignitability and burning behaviour of materials and products
53.040.20	Deli za transporterje	Components for conveyors

**SIST EN 12881-1:2006**

**en**

**iTeh STANDARD PREVIEW**  
**(standards.iteh.ai)**

SIST EN 12881-1:2006

<https://standards.iteh.ai/catalog/standards/sist/bbe52616-5dc8-41ad-88e6-929b49163077/sist-en-12881-1-2006>

ICS 13.220.40; 53.040.20

English Version

## Conveyor belts - Fire simulation flammability testing - Part 1: Propane burner tests

Courroies transporteuses - Essais simulation  
d'inflammation - Partie 1: Essais avec brûleur propane

Fördergurte - Brandtechnische Prüfungen - Teil 1:  
Prüfungen mit dem Propanbrenner

This European Standard was approved by CEN on 26 August 2005.

CEN members are bound to comply with the CEN/CENELEC Internal Regulations which stipulate the conditions for giving this European Standard the status of a national standard without any alteration. Up-to-date lists and bibliographical references concerning such national standards may be obtained on application to the Central Secretariat or to any CEN member.

This European Standard exists in three official versions (English, French, German). A version in any other language made by translation under the responsibility of a CEN member into its own language and notified to the Central Secretariat has the same status as the official versions.

CEN members are the national standards bodies of Austria, Belgium, Cyprus, Czech Republic, Denmark, Estonia, Finland, France, Germany, Greece, Hungary, Iceland, Ireland, Italy, Latvia, Lithuania, Luxembourg, Malta, Netherlands, Norway, Poland, Portugal, Slovakia, Slovenia, Spain, Sweden, Switzerland and United Kingdom.

[SIST EN 12881-1:2006](https://standards.iteh.ai/catalog/standards/sist/bbe52616-5dc8-41ad-88e6-929b49163077/sist-en-12881-1-2006)

<https://standards.iteh.ai/catalog/standards/sist/bbe52616-5dc8-41ad-88e6-929b49163077/sist-en-12881-1-2006>



EUROPEAN COMMITTEE FOR STANDARDIZATION  
COMITÉ EUROPÉEN DE NORMALISATION  
EUROPÄISCHES KOMITEE FÜR NORMUNG

Management Centre: rue de Stassart, 36 B-1050 Brussels

Contents	Page
Foreword .....	3
Introduction .....	4
1 Scope .....	5
2 Normative references .....	5
3 Propane gas supply .....	5
4 Method A – Two metre single burner test .....	6
4.1 Apparatus .....	6
4.2 Preparation of test pieces .....	9
4.3 Temperature at commencement of test .....	9
4.4 Number of tests .....	9
4.5 Procedure .....	10
4.6 Termination of tests .....	10
4.7 Measurement of damage to test pieces .....	10
4.8 Test report .....	11
5 Method B – Double burner test .....	12
5.1 Apparatus .....	12
5.2 Preparation of test pieces .....	13
5.3 Temperature at commencement of test .....	13
5.4 Number of tests .....	13
5.5 Procedure .....	14
5.6 Termination of tests .....	14
5.7 Measurement of damage to test pieces .....	14
5.8 Test report .....	15
6 Method C – Mid-scale fire propagation test .....	15
6.1 Apparatus .....	15
6.2 Preparation of test pieces .....	22
6.3 Installation of the test pieces and burner .....	22
6.4 Temperature at commencement of test .....	22
6.5 Number of tests .....	23
6.6 Procedure .....	23
6.7 Termination of tests .....	23
6.8 Expression of results .....	23
6.9 Exhaust temperature calibration .....	24
6.10 Test report .....	25
Annex ZA (informative) Relationship between this European Standard and the Essential Requirements of EU Directive 98/37/EC .....	26
Bibliography .....	27

## Foreword

This European Standard (EN 12881-1:2005) has been prepared by Technical Committee CEN/TC 188 “Conveyor belts”, the secretariat of which is held by BSI.

This European Standard shall be given the status of a national standard, either by publication of an identical text or by endorsement, at the latest by April 2006, and conflicting national standards shall be withdrawn at the latest by April 2006.

This European Standard has been prepared under a mandate given to CEN by the European Commission and the European Free Trade Association, and supports essential requirements of EU Directive(s).

For relationship with EU Directive(s), see informative Annex ZA, which is an integral part of this European Standard.

The other part of EN 12281 is:

EN 12881-2, *Conveyor belts – Fire simulation flammability testing – Part 2: Large scale fire test*

According to the CEN/CENELEC Internal Regulations, the national standards organizations of the following countries are bound to implement this European Standard: Austria, Belgium, Cyprus, Czech Republic, Denmark, Estonia, Finland, France, Germany, Greece, Hungary, Iceland, Ireland, Italy, Latvia, Lithuania, Luxembourg, Malta, Netherlands, Norway, Poland, Portugal, Slovakia, Slovenia, Spain, Sweden, Switzerland and United Kingdom.

SIST EN 12881-1:2006

<https://standards.iteh.ai/catalog/standards/sist/bbe52616-5dc8-41ad-88e6-929b49163077/sist-en-12881-1-2006>

## Introduction

This European Standard is a type B1 standard as stated in EN ISO 12100-1.

The provisions of this European Standard may be supplemented or modified by a type C standard.

The machinery concerned and the extent to which hazards, hazardous situations and events are covered are indicated in the scope of this European Standard.

**NOTE** For machines which are covered by the scope of a type C standard and which have been designed and built according to the provisions of that standard, the provisions of that type C standard take precedence over the provisions of this type B1 standard.

The methods of test described in this part of EN 12881 are intended to provide an indication of the reaction of a conveyor belt to a fire situation. However, in doing so attention is drawn to the fact that in assessing the overall flammability characteristics of conveyor belting for specific installations, it is not sufficient to rely solely on any single method of test but consideration has also to be given to the individual site location.

**WARNING — The tests described in this part of EN 12881 can generate large amounts of smoke and heat. It is therefore essential to conduct the tests with caution, having due regard to health and safety considerations and to terminate any test immediately if at any time it is considered advisable to do so. In this regard it is recommended that no test should be supervised by only one person.**

(standards.iteh.ai)

SIST EN 12881-1:2006

<https://standards.iteh.ai/catalog/standards/sist/bbe52616-5dc8-41ad-88e6-929b49163077/sist-en-12881-1-2006>

## 1 Scope

This part of EN 12881 describes three methods for measuring the propagation of a flame along a conveyor belt which has been exposed to a relatively high localised heat source such as a fire. The damage suffered by the conveyor belt, as well as its tendency to support combustion, are measured by observing the extent to which the fire spreads along the test piece.

Method A uses a test piece 2 m in length and consumes propane gas through the burner at the rate of  $(1,30 \pm 0,05)$  kg per 10 min.

Method B uses a test piece 2,5 m in length and consumes propane gas through two burners mounted above and below the test piece trestle at the rate of  $(1,30 \pm 0,05)$  kg per 10 min for each burner.

Method C uses a test piece 1,5 m in length and consumes propane gas through the burner at the rate of  $(565 \pm 10)$  g per 50 min.

## 2 Normative references

The following referenced documents are indispensable for the application of this European Standard. For dated references, only the edition cited applies. For undated references, the latest edition of the referenced document (including any amendments) applies.

EN 10088-3, *Stainless steels - Part 3: Technical delivery conditions for semi-finished products, bars, rods, wire, sections and bright products of corrosion resisting steels for general purposes*

EN 22768-1:1993, *General tolerances - Part 1: Tolerances for linear and angular dimensions without individual tolerance indications (ISO 2768-1:1989)*

ISO 65, *Carbon steel tubes suitable for screwing in accordance with ISO 7-1*

ISO 9162:1989, *Petroleum products – Fuels (Class F) – Liquefied petroleum gases – Specifications*

## 3 Propane gas supply

The burners used in each method shall be supplied from bottled propane gas complying with ISO 9162 which shall be fed to each burner, using high pressure propane hose having a minimum internal diameter of 6,3 mm, either:

- a) through a pressure reducing valve, a non-return valve and an orifice plate 1,7 mm thick with a 2,5 mm diameter hole; or
- b) through a pressure reducing valve and a non-return valve followed by a flowmeter calibrated to ensure that the correct mass of gas is consumed.

Before and during the test, immerse each gas cylinder to approximately two-thirds of its height in a bath of water at a temperature of  $(25 \pm 3)$  °C. Ensure that each gas cylinder is not emptied at the end of a test by more than 90 % of its gas mass capacity.

## 4 Method A – Two metre single burner test

### 4.1 Apparatus

**4.1.1 Gallery** (see Figure 1) having a cross section not greater than 6 m<sup>2</sup>, a height of not less than 1,9 m and not greater than 2,25 m and a width of not less than 1,9 m and not greater than 2,75 m through which air is drawn by an adjustable fan. The gallery shall have a concrete floor and shall be not less than 15,0 m long measured from the gallery entrance.

**4.1.2 Trestle** (see Figure 2) comprising a framework having internal dimensions 2,25 m long x 1,25 m wide and constructed of steel tubing complying with ISO 65, having a bore designation of DN 15 heavy series. The upper sides of the trestle frame shall be fitted with rod retainers to position and retain 15 steel bars manufactured from an austenitic chrome/nickel steel of an appropriate quality, such as 1-4310X<sub>10</sub>CrNi88 complying with EN 10088-3, resistant to rust, acid and heat. The bars shall be 10 mm diameter x 1,4 m in length and form the frame on which the belting rests. The upper surface of the bars shall be 350 mm from the floor.

**4.1.3 Burner**, constructed in accordance with Figure 3, comprising a square having side dimensions of (450 ± 9) mm and an overall height of (220 ± 5) mm. The burner shall be made of welded steel tube complying with ISO 65, having a bore designation of DN 15 medium or heavy series. The tubing shall have 52 holes, each having a diameter of (1,5 ± 0,1) mm, spaced at 50 mm intervals.

**4.1.4 Anemometer**, or other means of measuring the air velocity in the gallery, which shall be located at a height of 350 mm on the centreline of the gallery, at least 7,25 m inside the gallery entrance and 750 mm from the end of the trestle nearest the gallery entrance.

NOTE It is important that the air flow in the gallery is laminar and to this end equipment to assist in producing laminar flow may be used.

**4.1.5 Thermocouple**, to measure the temperature of the incoming air, located as shown in Figure 1.

<https://standards.iteh.ai/catalog/standards/sist/bbe52616-5dc8-41ad-88e6-929b49163077/sist-en-12881-1-2006>



Dimensions in millimetres

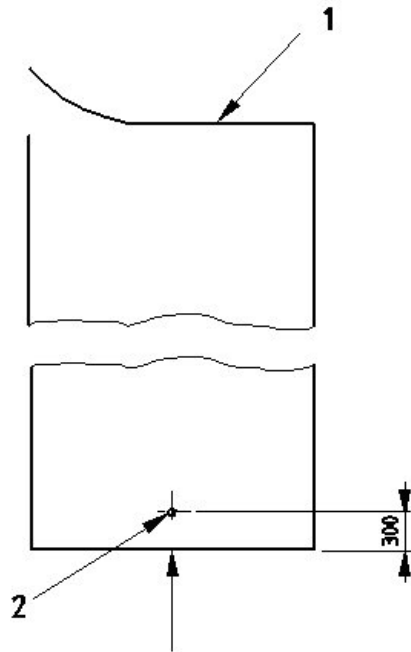

**iTeh STANDARD PREVIEW**  
**(standards.iteh.ai)**  
 a) Plan view of gallery

<https://standards.iteh.ai/catalog/standards/sist/bbe52616-5dc8-41ad-88e6-929b49163077/sist-en-12881-1-2006>

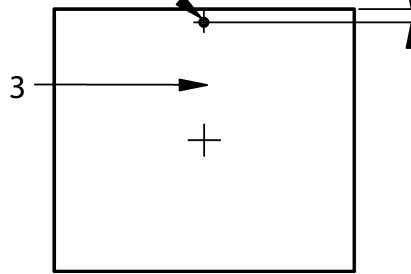

b) Cross-section of front of gallery

**Key**

- 1 Rear of gallery
- 2 Position of thermocouple on centre line
- 3 Front of gallery

**Figure 1 — Location of thermocouple for measuring the temperature of incoming air**

General manufacturing tolerances shall be according to EN 22768-1, unless otherwise stated.

Dimensions in millimetres

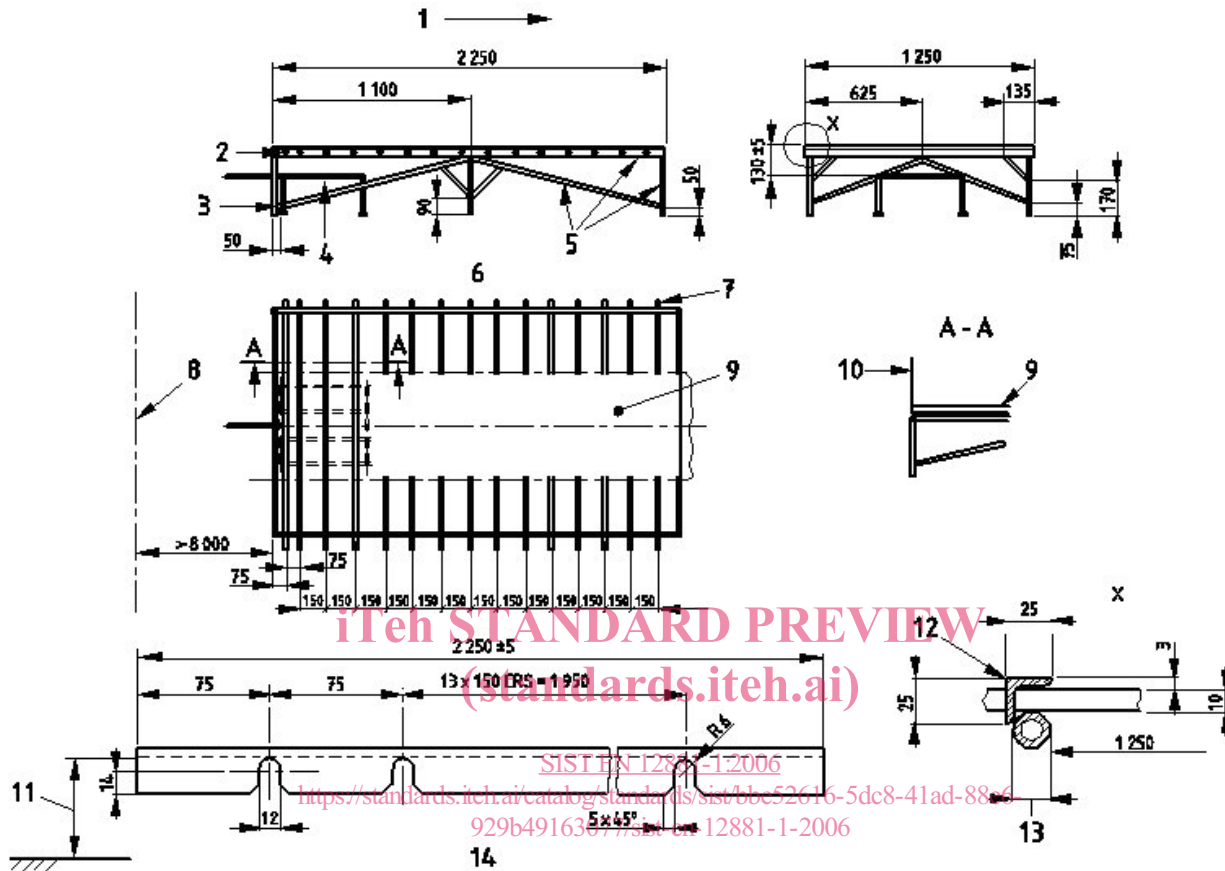

**Key**

- |   |   |    |  |
|---|---|----|--|
| 1 | Direction of air flow   | 9  | Test piece                                     |
| 2 | Additional bar  | 10 | Edge of test piece flush with front of trestle |
| 3 | To be clear of any cross bracing  | 11 | 350 mm to flow line                            |
| 4 | Propane burner  | 12 | Rod retainers                                  |
| 5 | DN 15 heavy series tube   | 13 | DN 15 heavy series trestle                     |
| 6 | Detail of trestle   | 14 | Detail of rod retaining angle                  |
| 7 | Bars made of austenitic chrome/nickel steel, diameter 10 mm, length 1,4 m |    |  |
| 8 | Gallery entrance  |    |  |

**Figure 2 — Propane burner trestle showing positions of burner and test piece**

Dimensions in millimetres

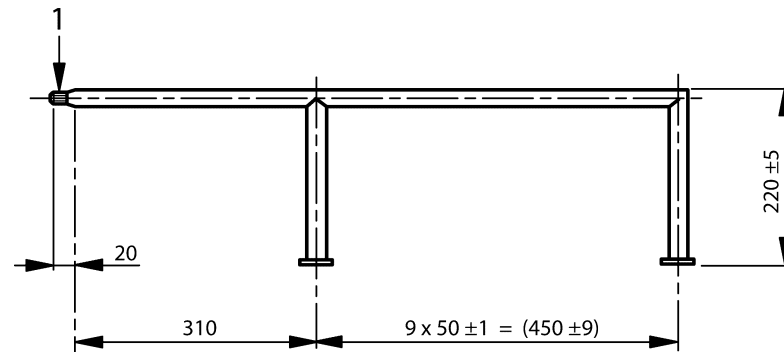

a) Elevation

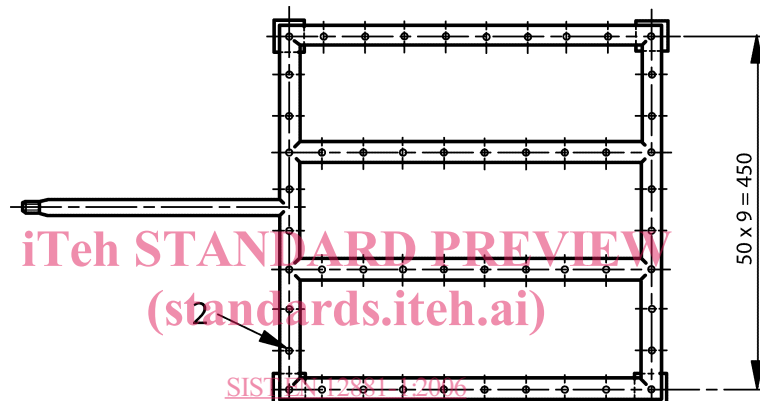

b) Plan view

**Key**

- 1 Threaded
- 2 Hole (x 52)

**Figure 3 — Burner for Method A****4.2 Preparation of test pieces**

Cut two test pieces, each 2 m long  $\times$  1 200 mm wide or of full width if the conveyor belt is less than 1 200 mm wide. Lay the test pieces out for 24 h in dry conditions at any ambient temperature above 0 °C immediately prior to testing to remove residual curvature.

**4.3 Temperature at commencement of test**

The ambient temperature at the commencement of the test shall be between 5 °C and 30 °C.

**4.4 Number of tests**

Carry out two tests, one on each side of the belt, so that both covers are tested.