

~~TC/SC ISO/TC 4/SC 5~~

Date: 2022-~~08-19~~09-28

ISO 3245:2022(E)

ISO/TC ~~4~~/SC 5

Secretariat: AFNOR

**Rolling bearings — Needle roller bearings with drawn cup and without inner ring —
Boundary dimensions, geometrical product specifications (GPS) and tolerance values**

iTeh STANDARD PREVIEW
(standards.iteh.ai)

ISO/FDIS 3245

<https://standards.iteh.ai/catalog/standards/sist/ae8332f9-fd9b-44f3-bef2-5214720bd400/iso-fdis-3245>

© ISO [2022]

All rights reserved. Unless otherwise specified, or required in the context of its implementation, no part of this publication may be reproduced or utilized otherwise in any form or by any means, electronic or mechanical, including photocopying, or posting on the internet or an intranet, without prior written permission. Permission can be requested from either ISO at the address below or ISO's member body in the country of the requester.

ISO Copyright Office

CP 401 • CH-1214 Vernier, Geneva

Phone: + 41 22 749 01 11

Email: copyright@iso.org

Website: www.iso.org

Published in Switzerland.

iTeh STANDARD PREVIEW (standards.iteh.ai)

ISO/FDIS 3245

<https://standards.iteh.ai/catalog/standards/sist/ae8332f9-fd9b-44f3-bef2-5214720bd400/iso-fdis-3245>

Contents

Foreword.....	iv
Introduction.....	v
1 Scope	1
2 Normative references	1
3 Terms and definitions.....	1
4 Symbols	2
5 Nominal boundary dimensions	5
6 Tolerances.....	7
6.1 General	7
6.2 Tolerance for the bore diameter.....	7
6.3 Tolerance for the drawn cup	9
6.3.1 Drawn cup width, C.....	9
6.3.2 End thickness of profiled end and flat end drawn cup C_1 and C_2.....	9
6.3.3 Chamfer dimension, r.....	9
Annex A (informative) Tolerances for shaft raceway and housing bore	10
Annex B (informative) Measuring and verification methods	13
Bibliography	18

[ISO/FDIS 3245](https://standards.iteh.ai/catalog/standards/sist/ae8332f9-fd9b-44f3-bef2-5214720bd400/iso-fdis-3245)

<https://standards.iteh.ai/catalog/standards/sist/ae8332f9-fd9b-44f3-bef2-5214720bd400/iso-fdis-3245>

Foreword

ISO (the International Organization for Standardization) is a worldwide federation of national standards bodies (ISO member bodies). The work of preparing International Standards is normally carried out through ISO technical committees. Each member body interested in a subject for which a technical committee has been established has the right to be represented on that committee. International organizations, governmental and non-governmental, in liaison with ISO, also take part in the work. ISO collaborates closely with the International Electrotechnical Commission (IEC) on all matters of electrotechnical standardization.

The procedures used to develop this document and those intended for its further maintenance are described in the ISO/IEC Directives, Part 1. In particular, the different approval criteria needed for the different types of ISO documents should be noted. This document was drafted in accordance with the editorial rules of the ISO/IEC Directives, Part 2 (see www.iso.org/directives).

Attention is drawn to the possibility that some of the elements of this document may be the subject of patent rights. ISO shall not be held responsible for identifying any or all such patent rights. Details of any patent rights identified during the development of the document will be in the Introduction and/or on the ISO list of patent declarations received (see www.iso.org/patents).

Any trade name used in this document is information given for the convenience of users and does not constitute an endorsement.

For an explanation ~~on~~ of the voluntary nature of standards, the meaning of ISO specific terms and expressions related to conformity assessment, as well as information about ISO's adherence to the World Trade Organization (WTO) principles in the Technical Barriers to Trade (TBT), see www.iso.org/iso/foreword.html ~~the following URL:~~ <https://standards.iteh.ai/catalog/standards/sist/ae8332f9-fd9b-44f3-bef2-5214720bd400/iso-fdis-3245>

~~The committee responsible for this~~ This document is was prepared by Technical Committee ISO/TC 4, Rolling bearings, Subcommittee SC 5, Needle, cylindrical and spherical roller bearings.

This fifth edition cancels and replaces the fourth edition (ISO 3245:2015), which has been technically revised.

The main changes ~~compared to the previous edition~~ are as follows:

- Figure ~~1a~~ 1 a) has been updated;
- ~~The~~ the symbol for characteristic ΔF_w s has been replaced with ΔF_{wg} ;
- Annex B on measuring and verification methods has been added.

Any feedback or questions on this document should be directed to the user's national standards body. A complete listing of these bodies can be found at www.iso.org/members.html.

Introduction

This International Standard document is a machine element geometry standard as defined in the geometrical product specification system (GPS system) as presented in matrix model of ISO 14638-1^[9].

The fundamental rules of ISO/GPS given in ISO 8015^[6] apply to this International Standard document and the default decision rules given in ISO 14253-1^[7] apply to specifications made in accordance with this International Standard document, unless otherwise indicated.

The connection between functional requirements, measuring technique and measuring uncertainty is always intended to be considered. For measurement uncertainty, it is intended that ISO 14253-2^[8] be considered.

Recommended values for the tolerances for shaft raceway and housing bore are given in Annex A.

Guidelines for measurement and verification of the specific characteristic of needle roller bearings with drawn cup and without inner ring are given in Annex B.

iTeh STANDARD PREVIEW
(standards.iteh.ai)

ISO/FDIS 3245

<https://standards.iteh.ai/catalog/standards/sist/ae8332f9-fd9b-44f3-bef2-5214720bd400/iso-fdis-3245>

Rolling bearings — Needle roller bearings with drawn cup and without inner ring — Boundary dimensions, geometrical product specifications (GPS) and tolerance values

1 Scope

This ~~International Standard document~~ specifies the boundary dimensions and preferred dimensions to be used for drawn cup needle roller bearings without inner ring as well as the minimum chamfer dimension limits. ~~Also specified are~~ This document also specifies the closed end thickness dimensions for bearings with one closed end.

In addition, this document specifies dimensional tolerances for the needle roller complement bore diameter and tolerances for the drawn cup width ~~are specified~~.

~~Informative values for the tolerances for shaft raceway and housing bore are given in Annex A.~~

~~Guidelines for measurement and verification of the specific characteristic of needle roller bearings with drawn cup and without inner ring are given in Annex B.~~

3.2 Normative references

The following documents, in whole or in part, are normatively referenced in this document and are indispensable for its application. For dated references, only the edition cited applies. For undated references, the latest edition of the referenced document (including any amendments) applies.

ISO 5593, *Rolling bearings — Vocabulary*

ISO 10579, *Geometrical product specifications (GPS) — Dimensioning and tolerancing — Non-rigid parts*

ISO 14405-1, *Geometrical product specifications (GPS) — Dimensional tolerancing — Part 1: Linear sizes*

ISO/TS 17863, *Geometrical product specification (GPS) — Tolerancing of moveable assemblies*

4.3 Terms and definitions

For the purposes of this document, the terms and definitions given in ISO 5593, ISO 14405-1 and the following apply. ~~ISO and IEC maintain terminology databases for use in standardization at the following addresses:~~

ISO and IEC maintain terminology databases for use in standardization at the following addresses:—

— ISO Online browsing platform: available at <https://www.iso.org/obp> ~~https://www.iso.org/obp~~

— IEC Electropedia: available at <https://www.electropedia.org/> ~~https://www.electropedia.org/~~

3.1 constraint diameter

D_{1c}

diameter of the feature used in constraint condition to evaluate ΔF_{wgn} characteristics

Note 1 to entry: It corresponds to the diameter of the master ring gauge in Annex B.

54 Symbols

For the purposes of this document, the symbols given in ISO 15241 and the following apply.

Descriptions for symbols are in accordance to GPS terminology. The dimensional specifications are described in Table 1 and Figure 1.

Figure 1 presents the dimensioning associated to a needle roller bearing, using the symbols introduced in Table 1.

Tolerance value associated to a characteristic is symbolized by t followed by the symbol of characteristic, for example, $t_{\Delta C_s}$.

In this ~~International Standard~~ document, the ISO default specification operator for size is according to ISO 14405-1; i.e. the two-point size is valid.

Table 1 — Symbols for nominal dimensions, characteristics and specification modifiers

Symbol for nominal size and distance ^a	Symbol for characteristic	Specification modifier ^b	Description
C			nominal drawn cup width
	ΔC_s	GN GN	deviation of minimum circumscribed size of drawn cup width from its nominal size
C_1			nominal end thickness of profiled end drawn cup
	C_{1s}	GN GN	single end thickness of profiled end drawn cup (minimum circumscribed distance)
C_2			nominal end thickness of flat end drawn cup
	C_{2s}	GN GN	single end thickness of flat end drawn cup (minimum circumscribed distance)
D			nominal drawn cup outside diameter
F_w			nominal bore diameter of needle roller complement
	ΔF_{wgn}^c	GX SN GX SN	deviation of the smallest ^d maximum inscribed cylinder sizes of bore diameter of needle roller complement from its nominal size

r		nominal chamfer ^e dimension
	r_s	single chamfer dimension

- a Symbols as defined in ISO 15241 except for the format used.
- b Symbols as defined in ISO 14405-1.
- c Constraint condition and specification modifiers for fixed parts and movable parts, ~~according to~~ shall be in accordance with ISO/TS 17863; see Figure 1.
- d Considering the influence of the rotation of the needle roller complement.
- e The chamfer is considered in this ~~International standard~~ document as a round corner.

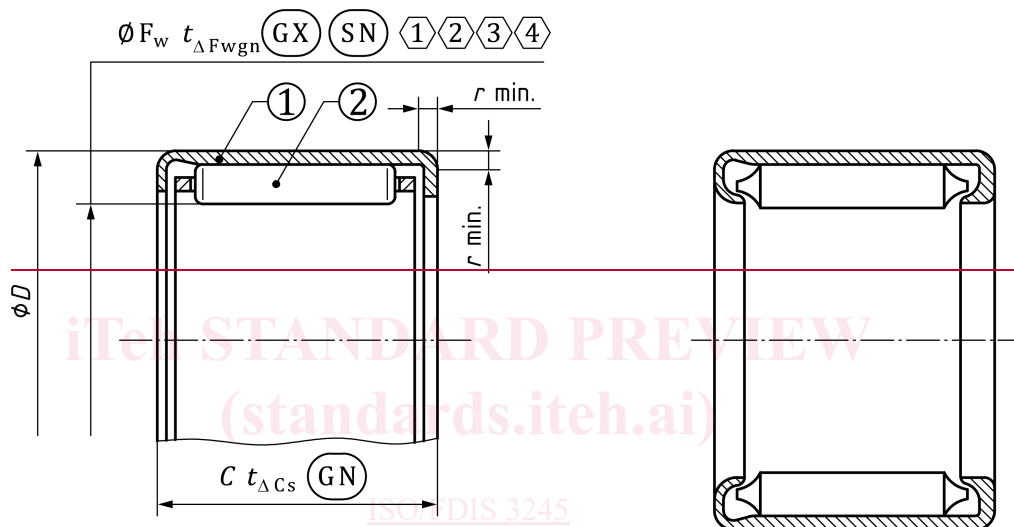

<https://standards.iteh.ai/catalog/standards/sist/ae8332f9-fd9b-44f3-bef2-5214720bd400/iso-3245>

a) Bearings with open ends

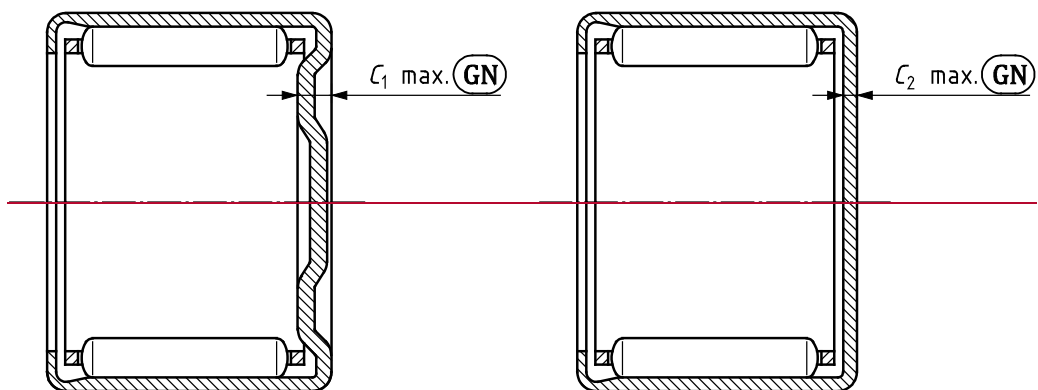

b) Bearings with one closed end



= valid in constraint condition by fitting $\textcircled{1}$ into a ring gage having a bore diameter equal to D_{1c} according to Table 4 or Table 5



= FP $\textcircled{1}$ - MP $\textcircled{2}$

 = needle rollers shall be in contact with the raceway of the drawn cup

 = in any rotation, in a coaxial direction

Key

-  drawn cup
-  needle roller complement

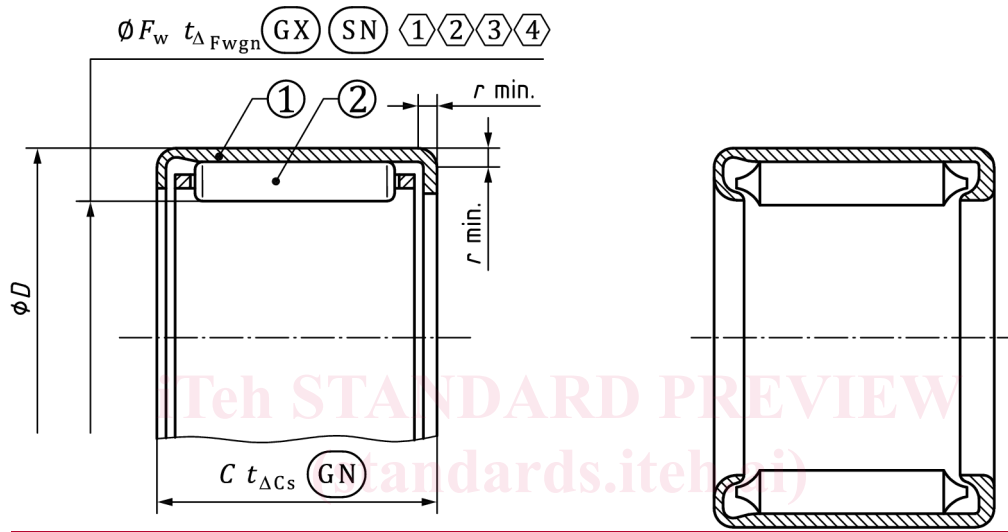



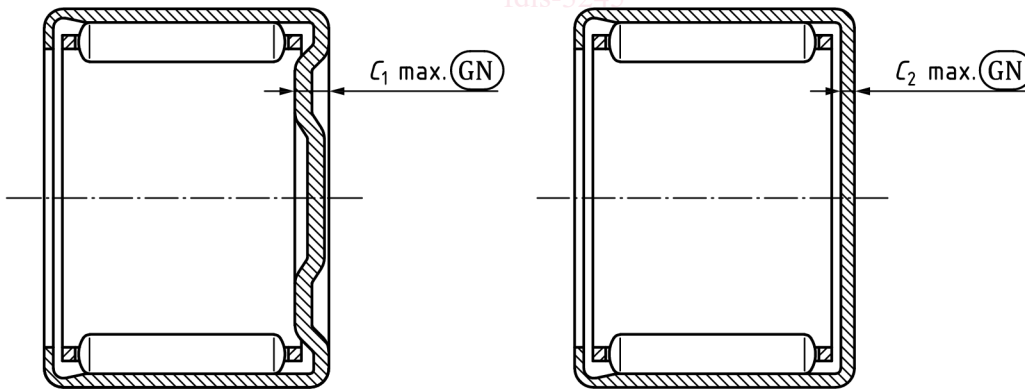



a) Bearings with open ends



b) Bearings with one closed end

Key

-  valid in constraint condition by fitting  into a ring gage having a bore diameter equal to D_{Ic} according to Table 4 or Table 5
-  FP  - MP 
-  needle rollers shall be in contact with the raceway of the drawn cup

④ in any rotation, in a coaxial direction① drawn cup② needle roller complement

Figure 1 — Example of drawn cup needle roller bearing without inner ring design

6.5 Nominal boundary dimensions

The nominal boundary dimensions of drawn cup needle roller bearings, without inner ring, one closed end and open ends, of diameter series 1D are given in Table 2, those of diameter series 2D are given in Table 3.

Table 2 — Nominal boundary dimensions of needle roller bearings without inner ring, with open ends or one closed end — Diameter series 1D

Dimensions in millimetres

F_w	D	C								C_1^a	C_2^a	r^b
		Dimension series										
		21D	31D	41D	51D	61D	71D	81D	91D			
4	8	7	<u>8</u>	9	—	—	—	—	—	1,9	1	0,3
5	9	7	8	9	—	—	—	—	—	1,9	1	0,4
6	10	7	8	9	10	—	—	—	—	1,9	1	0,4
7	11	7	8	9	10	12	—	—	—	1,9	1	0,4
8	12	7	8	9	10	12	—	—	—	1,9	1	0,4
9	13	7	8	9	<u>10</u>	12	14	—	—	1,9	1	0,4
10	14	7	8	9	<u>10</u>	12	14	—	—	1,9	1	0,4
12	16	7	8	9	<u>10</u>	12	14	—	—	1,9	1	0,4
14	20	10	<u>12</u>	14	<u>16</u>	18	20	—	—	2,8	1,3	0,4
15	21	10	12	14	16	18	20	—	—	2,8	1,3	0,4
16	22	10	<u>12</u>	14	<u>16</u>	18	20	—	—	2,8	1,3	0,4
17	23	10	12	14	16	18	20	—	—	2,8	1,3	0,4
18	24	10	<u>12</u>	14	<u>16</u>	18	20	—	—	2,8	1,3	0,4
20	26	10	<u>12</u>	14	<u>16</u>	18	20	—	—	2,8	1,3	0,4
22	28	10	<u>12</u>	14	<u>16</u>	18	20	—	—	2,8	1,3	0,4
25	32	12	14	<u>16</u>	18	<u>20</u>	24	28	32	2,8	1,3	0,8
28	35	12	14	<u>16</u>	18	<u>20</u>	24	28	32	2,8	1,3	0,8
30	37	12	14	<u>16</u>	18	<u>20</u>	24	28	32	2,8	1,3	0,8
32	39	12	14	16	18	20	24	28	32	2,8	1,3	0,8
35	42	12	14	<u>16</u>	18	20	24	28	32	2,8	1,3	0,8