



Standard Test Method for Calibration of Helium Leak Detectors by Use of Secondary Standards¹

This standard is issued under the fixed designation F 78; the number immediately following the designation indicates the year of original adoption or, in the case of revision, the year of last revision. A number in parentheses indicates the year of last reapproval. A superscript epsilon (ϵ) indicates an editorial change since the last revision or reapproval.

1. Scope

1.1 This test method covers a procedure for calibrating a mass spectrometer-type helium leak detector with a series of commercially available calibrated leaks without need for recourse to a primary standard.

1.2 Leak detector parameters determined by this test method include:

1.2.1 Minimum detectable signal, drift noise (8.5, with recorder; 8.6, without recorder),

1.2.2 Response time,

1.2.3 Minimum detectable leak rate, and

1.2.4 Sensitivity.

1.3 *This standard does not purport to address the safety concerns, if any, associated with its use. It is the responsibility of the user of this standard to establish appropriate safety and health practices and determine the applicability of regulatory limitations prior to use.*

2. Referenced Documents

2.1 *ASTM Standards:*

E 1 Specification for ASTM Thermometers²

E 425 Definitions of Terms Relating to Leak Testing³

3. Terminology

3.1 *Definitions:*

3.1.1 *calibrated leak—in leak detection*, a device that permits leakage through it at a specified rate, of a specific gas, under specific conditions, with the downstream side of the device exposed to a pressure sufficiently low to have negligible effect on the leak rate.

3.1.2 *minimum detectable signal—in leak detection*, the smallest unambiguous output signal that can be derived from a given particular leak detector. Units are detector scale divisions.

3.1.2.1 *Discussion*—The minimum detectable signal is determined by the noise present in, and drift of, the output signal.

3.1.3 *standard leak rate—in leak detection*, the rate of flow of atmospheric air of dewpoint less than -25°C through a leak

¹ This test method is under the jurisdiction of ASTM Committee F-1 on Electronic and is the direct responsibility of Subcommittee F 01.03 on Metallic Materials.

Current edition approved Dec. 10, 1997. Published March 1998. Originally published as F 78 – 67 T. Last previous edition F 78 – 79 (1991) ^{ϵ 1}.

² *Annual Book of ASTM Standards*, Vol 14.03.

³ Discontinued, see 1991 *Annual Book of ASTM Standards*, Vol 03.03.

under standard conditions specified as follows: (1) the inlet pressure shall be 1 standard atmosphere $\pm 5\%$ (101 ± 5 kPa), (2) the outlet pressure shall be less than 1 kPa (0.01 atm), and (3) the temperature shall be $23 \pm 3^{\circ}\text{C}$.

3.2 *Definitions of Terms Specific to This Standard:*

3.2.1 *response time—of a leak detector, for the purposes of this test method*, a measure of the speed of response of the detector to an incoming helium sample.

3.2.1.1 *Discussion*—In this test method the cleanup time and response time are assumed to be equal.

3.2.2 *sensitivity—of a leak detector, for the purposes of this test method*, the ratio of the change in the output signal to the applied helium leak rate.

3.3 Other terms used in this test method are defined in Definitions E 425.

4. Summary of Test Method

4.1 At least three calibrated leaks are tested on a helium leak detector, and a correlation is obtained between the output indication of the leak detector and the leak rate of the calibrated leaks. These readings are used to plot a calibration line from which intermediate values, within specified limits, may be read.

5. Interferences

5.1 Certain materials, particularly organic compounds, will entrap or hold helium tracer gas. Use of such materials in connections between the calibrated leak and the leak should be minimized to avoid erroneous results. (If the net output readings from any calibrated leak consistently lie outside the established limits, the leak should be returned to the supplier for a recalibration check.)

5.2 The background reading, B , should be at most one quarter of the output reading, A . If the value of B approaches that of A , the accuracy of the determination of N will suffer (see 9.3.1).

6. Apparatus

6.1 *Calibrated Leaks*—At least three commercial devices incorporating leaks, one having a leak rate of approximately 10^{-9} atm·cm³·s⁻¹ (10^{-10} Pa·m³·s⁻¹), a second having a leak value in the nominal range from 10^{-8} to 10^{-7} atm·cm³·s⁻¹ (10^{-9} to 10^{-8} Pa·m³·s⁻¹), and the third having a leak rate of approximately 10^{-6} atm·cm³·s⁻¹ (10^{-7} Pa·m³·s⁻¹).

6.1.1 The calibrated leaks shall be obtained from at least

two independent suppliers.

6.1.2 The calibrated leaks shall have been calibrated with helium gas at a pressure of approximately 1 standard atmosphere $\pm 5\%$ (101 ± 5 kPa).

6.1.3 The following information shall be provided with each calibrated leak:

6.1.3.1 Calibrated leak rate, $\text{atm}\cdot\text{cm}^3\cdot\text{s}^{-1}$ (or $\text{Pa}\cdot\text{m}^3\cdot\text{s}^{-1}$),

6.1.3.2 Date of calibration,

6.1.3.3 Temperature of calibration, $^{\circ}\text{C}$,

6.1.3.4 Temperature coefficient, $\text{atm}\cdot\text{cm}^3\cdot\text{s}^{-1}\cdot^{\circ}\text{C}^{-1}$ (or $\text{Pa}\cdot\text{m}^3\cdot\text{s}^{-1}\cdot^{\circ}\text{C}^{-1}$), and

6.1.3.5 If a reservoir is an integral part of the calibrated leak, the internal pressure in the reservoir, atm (or Pa) and an aging correction.

NOTE 1—It is preferable that five, rather than three, calibrated leaks be used for initial calibrations of helium leak detectors by this method. At least two leaks shall be obtained from each of two independent suppliers when more than three leaks are used.

NOTE 2—Although the data on which this specification has been based were obtained largely from permeation-type leaks, the calibrated leaks may be of various types such as capillary, pinched tubing, tapered plug, etc. However, it is recommended that, with all types of leaks, the manufacturer's recommendations be followed to avoid erroneous test results.

6.2 *Thermometer*, accurate to $\pm 1^{\circ}\text{C}$ or better in the range from 18 to 28°C inclusive. A thermometer conforming to Thermometer 63C as prescribed in Specification E 1 is suitable.

6.3 *Chart Recorder*, for determining Minimum Detectable Leak, Method A; an instrument suitable for recording the output of the leak detector under test as a function of time.

6.3.1 The chart recorder shall incorporate a gain control to permit the deflection of the recorder stylus to be adjusted to full scale when the leak detector meter is reading full scale with the leak detector at its most sensitive detection setting.

6.3.2 The time constant of the chart recorder shall not be greater than that of the leak-detector output meter.

6.3.3 The chart recorder shall be capable of continuous recording for at least 1 h.

6.4 *Stopwatch*, calibrated to read in tenths of a second to 60 min over an interval of at least 1 h.

6.5 *Leak Auxiliary Manifold*—If not incorporated in the leak detector, evacuable means for connecting the calibrated leak to the leak detector, incorporating a roughing pump, leak valve, and pump valve (see Fig. 1).

6.5.1 The roughing pump shall have sufficient pumping capacity to evacuate the leak auxiliary manifold to an absolute

pressure of less than 50 millitorr (or 7 Pa).

6.5.2 The leak valve shall not act as a source of helium.

6.5.3 Valves and connections shall contain a minimum of rubber or other polymeric surfaces that can serve as virtual leaks.

NOTE 3—It is preferable that the only exposed polymeric surfaces be those of O-rings.

7. Material

7.1 *Helium Gas*— for use with calibrated leaks not having an integral reservoir. The helium gas shall have a purity of at least 99.9 % and a supply pressure of nominally 1 atm (101 kPa).⁴

8. Procedure

8.1 Connect the helium leak detector to be tested to a source of electric power conforming in voltage, frequency, and degree of regulation to the manufacturer's specifications.

8.2 Turn on the detector for the warm-up period specified by the manufacturer.

8.3 Adjust the detector in accordance with the manufacturer's instructions for maximum sensitivity and for maximum output for a given helium input.

8.4 Close the inlet valve of the detector.

8.5 If the electron-producing filament is not on, turn it on and adjust the detector zero position control to obtain an output signal of at least 10 % of the most sensitive scale.

8.6 If the detector has no recorder output or if a suitable chart recorder is not available, continue with 8.8; otherwise, continue with 8.7.

8.7 *Minimum Detectable Signal, Test Method A, with Recorder:*

8.7.1 Connect the detector output to the recorder.

8.7.2 Record the detector output for 60 min or until the output indication has reached full scale. Do not readjust any controls during the recording period.

8.8 *Minimum Detectable Signal, Test Method B, without Recorder:*

8.8.1 Observe the detector meter and record its indications as follows. Do not readjust the controls for the 60-min period of this test.

8.8.1.1 Record the pointer deflection, in scale divisions, at time $T = 0$ min.

8.8.1.2 Record the minimum and maximum pointer deflections occurring in the interval from time $T = 0$ to $T = 1$ min.

8.8.1.3 Record the minimum and maximum pointer deflections occurring in the interval from time $T = 9$ to $T = 10$ min; record the deflection occurring at $T = 10$ min.

8.8.1.4 In like manner, record the minimum, maximum, and terminal deflections occurring during every tenth minute for the 60-min period, that is, from $T = 19$ to $T = 20$ min, $T = 29$ to $T = 30$ min, etc.

8.9 *Minimum Detectable Leak Rate and Sensitivity:*

8.9.1 Connect the apparatus as shown in Fig. 1, including one of the calibrated leaks.

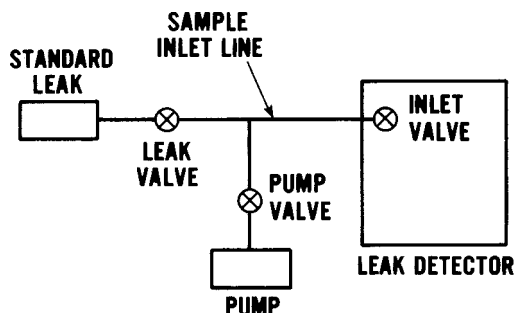

FIG. 1 Schematic Diagram of Apparatus for the Calibration of the Helium Mass Spectrometer Leak Detector

⁴ Commercially available compressed helium of the specified minimum purity, supplied in suitable cylinders with appropriate regulators, has been found suitable for this test method.

8.9.2 With the filament on, zero the deflector meter reading.

8.9.3 Open the leak valve and then the pump valve.

8.9.4 If the calibrated leak has an integral reservoir, continue with 8.9.6; otherwise continue with 8.9.5.

8.9.5 Connect a source of helium at a pressure of 1 atm (101 kPa) to the calibrated leak.

8.9.6 Evacuate the atmospheric air present in the connections between the leak and the leak detector (to protect the leak detector).

NOTE 4—It may be desirable to turn off the filament of the mass spectrometer tube before continuing with 8.9.7.

8.9.7 Open the inlet valve slowly and maintain the leak detector pressure within the operational pressure range specified by the manufacturer.

8.9.8 Close the pump valve.

8.9.9 With the inlet valve fully open, observe the pressure indicator of the leak detector. Do not continue until this reading shows no observable change over 1 min.

8.9.10 Turn on the filament of the mass-spectrometer tube if it is not on.

8.9.11 Adjust the range multiplier to bring the detector meter reading on scale. When the meter pointer shows a steady deflection, with no observable change over 1 min, record the reading, A , in scale divisions. If required, adjust the gain control, but do not readjust any controls thereafter for the duration of this test.

8.9.12 Calculate and record a value equal to 37 % of A .

8.9.13 Using the thermometer, measure the ambient temperature near the leak to the nearest 1°C. Record this value.

8.9.14 Start the stopwatch and simultaneously close the leak valve *as rapidly as possible*.

8.9.15 Observe the detector meter continuously. Stop the stopwatch when the reading has decreased to 37 % of A (this value was recorded in 8.9.12). Record the reading of the stopwatch to the nearest 1 s as T , the response time.

NOTE 5—The actual value recorded is the cleanup time, which for the purposes of this method is taken as the response time.

8.9.16 Continue to observe the detector meter. When the pointer shows a steady deflection, with no observable change over 1 min, record the reading in scale divisions as the background reading, B .

8.9.17 Close the inlet valve, vent the sample inlet line to atmosphere, and replace the calibrated leak with another.

8.9.18 Repeat steps 8.9.1 through 8.9.11, 8.9.13, and 8.9.14 through 8.9.17 until each of the remaining calibrated leaks has been run.

9. Calculations

9.1 Minimum Detectable Signal, Test Method A:

9.1.1 If spikes appear in the chart recorder trace, construct a smooth curve that represents the average values of the detector output.

9.1.2 From the smoothed curve, determine the detector output at the beginning and at the end of each minute, in chart scale divisions. Record these values.

9.1.3 Calculate and record the change in output for each 1-min period. Compare each of these values to a reference value of ½ % of the full-scale chart reading.

9.1.3.1 If the change in output per minute is always greater than or equal to this reference value, identify by inspection the largest of these changes and record this value, in chart scale divisions per minute, as the drift.

9.1.3.2 If the change in output per minute is always less than this reference value, calculate the total change in the 60-min observation period and divide this value by 60. Record the quotient in chart scale divisions per minute as the drift.

9.1.4 Examine the recorded output curve and determine if spikes appear on both sides of the smoothed curve.

9.1.4.1 If they do, identify the two spikes, one on each side of the smoothed curve, that extend furthest from the curve. Measure the departures, in chart scale divisions, and add the two figures. Record this sum as the noise.

9.1.4.2 If spikes appear on only one side of the smoothed curve, record *twice* the largest departure from the curve, in chart scale divisions, as the noise.

9.1.5 Calculate and record the sum of the drift and noise. Compare this value to a reference value of 2 % of the full-scale chart reading.

9.1.5.1 If the sum of the drift and noise is greater than or equal to this reference value, record it, in chart scale divisions, as the minimum detectable signal.

9.1.5.2 If the sum is less than this reference value, record the reference value as the minimum detectable signal.

9.1.6 Convert the values for drift, noise, and minimum detectable signal, recorded in chart scale divisions, into equivalent meter scale divisions as follows:

9.1.6.1 Determine and record the ratio of full-scale meter divisions to the number of full-scale chart divisions.

9.1.6.2 Multiply by this ratio the values recorded in 9.1.3 (drift), 9.1.4 (noise), and 9.1.5 (minimum detectable signal). Record these values as the drift, noise, and minimum detectable signal, respectively, expressed in meter scale divisions.

NOTE 6—For the purposes of this test method, it is acceptable to sum drift and noise and to express the result in scale divisions, even though drift has units of scale divisions per unit time.

9.2 Minimum Detectable Signal, Test Method B:

9.2.1 Calculate and record the change in output between the initial and final meter readings for each of the 10-min intervals, that is, between $T = 0$ and $T = 10$ min, $T = 10$ and $T = 20$ min, $T = 20$ and $T = 30$ min, etc.

9.2.2 Divide each of these changes in output signal by 10. Record these values and compare them to a reference value of ½ % of the full-scale meter reading.

9.2.2.1 If the change in meter readings per 10 min is always greater than or equal to this reference value, identify by inspection the largest of these changes and record this value, in meter scale divisions per minute, as the drift.

9.2.2.2 If the change in meter readings per 10 min is always less than this reference value, calculate the total change in the 60-min period. Divide the total change value by 60 and record the result as the drift.

9.2.3 Calculate and record the differences in meter readings between the maximum and minimum signals for each of the 10th minute intervals including the first minute. By inspection, identify the largest of these differences and record this value in meter scale divisions as the noise.