



Designation: B871 – 01 (Reapproved 2013)

Standard Test Method for Tear Testing of Aluminum Alloy Products¹

This standard is issued under the fixed designation B871; the number immediately following the designation indicates the year of original adoption or, in the case of revision, the year of last revision. A number in parentheses indicates the year of last reapproval. A superscript epsilon (ϵ) indicates an editorial change since the last revision or reapproval.

1. Scope

1.1 This test method covers the static tear test of aluminum alloy products using specimens that are 0.040 in. (1 mm) to 0.250 in. (6.35 mm) thick.

1.2 This test method is applicable to aluminum alloy products having a minimum thickness of 0.040 in. (1 mm).

1.3 This test method provides a measure of both notch toughness and resistance to crack propagation with the primary use as a screening or merit rank test.

1.4 The reliability of the tear test has been established in various research programs by reasonably good correlations between data from the tear tests and fracture toughness tests.^{2,3}

NOTE 1—Direct measurement of fracture toughness may be made in accordance with Practices B645, B646 and Test Method E399.

1.5 The values stated in inch-pound units are to be regarded as the standard. The values given in parentheses are for information only.

1.6 *This standard does not purport to address all of the safety concerns, if any, associated with its use. It is the responsibility of the user of this standard to establish appropriate safety and health practices and determine the applicability of regulatory limitations prior to use.*

2. Referenced Documents

2.1 ASTM Standards:⁴

B557 Test Methods for Tension Testing Wrought and Cast Aluminum- and Magnesium-Alloy Products

B645 Practice for Linear-Elastic Plane-Strain Fracture Toughness Testing of Aluminum Alloys

¹ This test method is under the jurisdiction of ASTM Committee B07 on Light Metals and Alloys and is the direct responsibility of Subcommittee B07.05 on Testing.

Current edition approved May 1, 2013. Published August 2013. Originally approved in 1996. Last previous edition approved in 2007 as B871–01 (2007). DOI: 10.1520/B0871-01R13.

² Kaufman, J. G., and Holt, Marshall, "Fracture Characteristics of Aluminum Alloys," Alcoa Research Laboratories Technical Paper No. 18.

³ Kaufman, J. G., and Knoll, A. H., "Kahn-Type Tear Tests and Crack Toughness of Aluminum Sheet," Metals Research and Standards, April 1964, pp. 151–155.

⁴ For referenced ASTM standards, visit the ASTM website, www.astm.org, or contact ASTM Customer Service at service@astm.org. For *Annual Book of ASTM Standards* volume information, refer to the standard's Document Summary page on the ASTM website.

B646 Practice for Fracture Toughness Testing of Aluminum Alloys

E4 Practices for Force Verification of Testing Machines

E83 Practice for Verification and Classification of Extensometer Systems

E338 Test Method of Sharp-Notch Tension Testing of High-Strength Sheet Materials (Withdrawn 2010)⁵

E399 Test Method for Linear-Elastic Plane-Strain Fracture Toughness K_{Ic} of Metallic Materials

3. Terminology

3.1 Definitions of Terms Specific to This Standard:

3.1.1 *initiation energy, IE (FL)*—the amount of energy required to initiate a crack in a tear specimen. Initiation energy is determined by integrating the area under the force-displacement curve from the beginning of the test to the point of maximum force.

3.1.2 *propagation energy, PE (FL)*—the amount of energy required to propagate a crack in a tear specimen. Propagation energy is determined by integrating the area under the force-displacement curve from the point of maximum force to the point of complete fracture.

3.1.3 *tear resistance*—a general term describing the resistance of a material to crack propagation under static loading, either in an elastic or plastic stress field.

3.1.4 *tear strength, TS (FL⁻²)*—the maximum nominal direct and bending stress that the tear specimen is capable of sustaining.

3.1.5 *tear strength to tensile yield strength ratio (TYR)*—the ratio of the tear strength to tensile yield strength of the material determined in accordance with Test Methods B557.

3.1.6 *unit propagation energy, UPE (FL⁻¹)*—the amount of energy required to propagate a crack across a tear specimen divided by the original net area of the specimen.

4. Summary of Test Method

4.1 The tear test involves a single edge notched specimen that is statically loaded through pin loading holes. The force and displacement required to fracture the specimen are recorded for analysis.

⁵ The last approved version of this historical standard is referenced on www.astm.org.

4.2 Tear test specimens should be fractured using any mechanical test machine capable of quasi-static loading at a crosshead speed of 0.05 in./min (1.3 mm/min) or less.

5. Significance and Use

5.1 The significance of the tear test is similar to that of the notch-tensile test, and its primary usefulness is as an indicator of toughness or as a ranking test as described in Test Method E338 and Practice B646.

5.1.1 This test method provides a comparative measure of resistance of aluminum alloys and products to unstable fracture originating from the presence of crack-like stress concentrators. This test method is not intended to provide an absolute measure of resistance to crack propagation that might be used in the design of a structure.

5.2 Values of the energies required to initiate and propagate cracks in tear specimens are determined by measuring or integrating the appropriate areas under the test curve developed during the test.

5.3 The unit propagation energy (UPE) is the primary result of the tear test. This value provides a measure of the combination of strength and ductility that permits a material to resist crack growth under either elastic or plastic stresses. The UPE value normally will exhibit greater scatter than conventional tensile or yield strength values. In order to establish a reasonable estimate of average properties, it is recommended that replicate specimens be tested for each metal condition being evaluated. The UPE value has significance as a relative index of fracture toughness.

5.4 The ratio of the tear strength to the tensile yield strength is a measure of notch toughness comparable to the notch-yield ratio from notch-tensile tests carried out in accordance with Test Method E338. It is of value in relative ranking of materials with regard to their toughness.^{2,3}

5.5 The numerical results of the test are dependent upon the specimen size and geometry, although specimen thicknesses over the range of 0.063 in. (1.6 mm) to 0.100 in. (2.5 mm) have not shown a significant effect on tear strength (TS) and unit propagation energy (UPE).⁶ These values may exhibit a dependency to thickness when the specimen thickness is outside of this stated range and care shall be taken when using this data.

5.6 The tear test can serve the following purposes:

5.6.1 In the research and development of materials, to study the effects of variables of composition, processing, heat treatment, etc.

5.6.2 In service evaluation, to compare the relative crack propagation resistance of a number of aluminum alloys or products that are otherwise equally suitable for an application.

5.6.3 For specifications of material acceptance and manufacturing quality control when there is a sound basis for establishing a minimum acceptable tear test property, that is, UPE.

5.7 The reliability of the tear test has been well established by developing reasonably good correlations^{2,3} between tear test

data and fracture toughness test data of aluminum alloys and products, as determined in accordance with Practices B645, B646 and Test Method E399. Limited data suggest that the test may be sensitive to crosshead rates above 0.5 in./min.

6. Apparatus

6.1 The test shall be conducted with a tension testing machine conforming to the requirements of Practices E4.

6.2 The device for transmitting force to the specimen shall be such that force axis coincides with the root of the edge notch. A satisfactory arrangement for force application incorporates clevises having hardened pins that pass through the holes in the specimen. The diameter of the hardened pins is slightly smaller than that of the holes. Spacing washers of the necessary thickness shall be used to center the specimen in the clevises. A typical arrangement is shown in Fig. 1.

6.3 Displacement at the notch tip is measured by displacement gages or similar devices that are mounted on the specimen or the clevis at a point corresponding to the force axis of the specimen. The devices shall be calibrated in accordance with Practice E83. For ductile materials, it is recommended that the displacement gages have a travel capability of at least 0.5 in.

6.4 The use of crosshead displacement is not recommended because of the fact that all deformation in the test fixtures and specimen clevis is then included in the displacement measurement and contributes to the apparent initiation and propagation energies measured. If crosshead displacement is used, the data cannot be compared directly with data measured in accordance

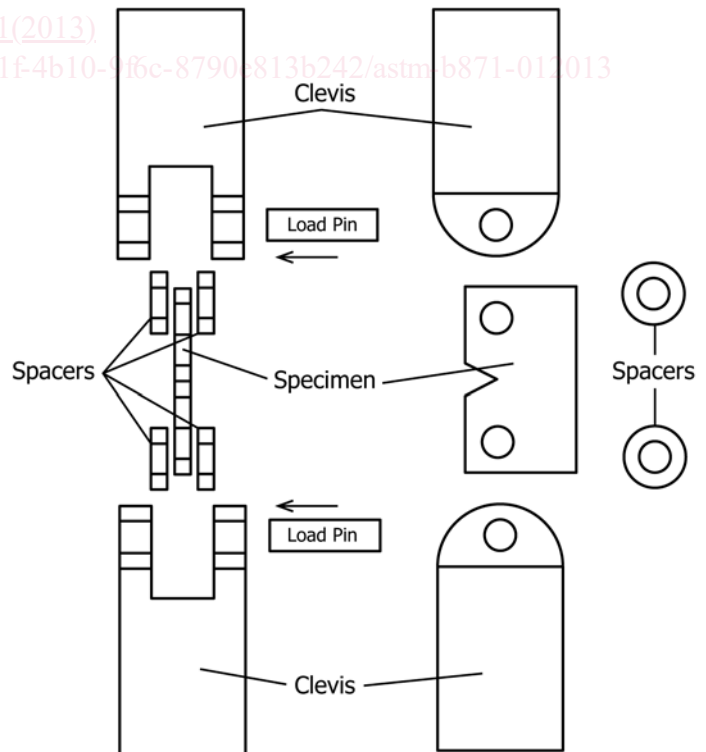

FIG. 1 Tear Test Specimen Clevis Arrangement

⁶ Kaufman, J. G., and Reedy, J. F., "Description and Procedure for Making Kahn-Type Tear Tests," Alcoa Research Laboratory Report 9-M 681, Feb. 10, 1966.

with 6.2 unless a calibration comparison with a number of standard materials is conducted.

6.5 Because testing machine stiffness can influence the data recording in the tear test, the use of a relatively stiff machine is recommended. Further, it is recommended that for consistency of data, the same testing machine or machines be used for all tests that are intended for direct comparison and relative rating of a group of materials. If comparisons are to be made between different machines in one location or among several locations/organizations, it is recommended that a series of calibration tests be run on a group of materials with a range of toughness levels.

6.5.1 If rapid fracture of tear specimens is regularly observed, as described in 9.6.1, this is an indication that a stiffer testing machine and related apparatus is required to minimize extraneous energy release and deformation during the tear test.

7. Test Specimens

7.1 The design of the standard specimen is shown in Fig. 2. The dimensions shall be as indicated and pin loading shall be used. Specimen Types 1 and 2 are considered “standard” sizes. Types 3, 4 and 5 have the same dimensions as Types 1 and 2, except for thickness, and are used only in instances where it is desirable to test the full thickness of products up to 0.250 in. (6.35 mm) in thickness. For specimens that are machined to thickness, equal amounts of material are typically removed from each side.

7.1.1 For products thicker than 0.100 in. (2.54 mm), and especially for those thicker than 0.250 in. (6.35 mm), it is recommended that 0.100 in. (2.54 mm) thick specimens be machined from the appropriate orientations to maximize the ease of comparison with data for other products and lots.

7.2 The minimum specimen thickness shall be 0.040 in. (1 mm). Type 1 specimen dimensions are used for this thickness.

7.3 Measure the specimen thickness, B, to the nearest 0.0005 in. (0.013 mm) at not less than three positions between the machined notch and the back of the specimen and record the average value. If the variation about the average is greater than ±2 %, the specimen should be repaired or discarded. Measure the distance between the notch root and the back edge of the specimen, the net section width, to the nearest 0.001 in. (0.025 mm) and record. Measure the notch root radius to the nearest 0.00025 in. (0.006 mm) and record.

7.3.1 The sharpness of the machined notch is critical to the tear specimen, and special care is required to prepare the notch. For each specimen, the notch root radius and notch location with respect to pin hole centers shall be measured prior to testing, and specimens that do not meet the requirements of Fig. 2 shall be discarded or reworked.

8. Specimen Orientation

8.1 The tear properties of aluminum alloys usually depend on the specimen orientation and the direction in which the force is applied relative to the grain flow of the specimen. The specimen orientation and loading direction should be identified by the following systems:

8.1.1 The reference direction for rectangular shapes are indicated in Fig. 3 and are suitable for sheet, plate, extrusions, forgings and other shapes of nonsymmetrical grain flow.

8.1.2 The reference direction for certain cylindrical shapes where the longitudinal axis is the predominant grain flow are indicated in Fig. 4. The terminology in Fig. 4 is applicable to rolled, drawn, extruded, or forged round rod.

8.2 A two letter code is used in Figs. 3 and 4 to describe the specimen orientations and loading directions. The first letter designates the direction of loading, while the second letter designates the direction of crack propagation. The most commonly used specimen orientations are the L-T, T-L, and S-L for rectangular shapes in 8.1.1 and L-R, C-R, and R-L for cylindrical shapes in 8.1.2.

9. Procedure

9.1 Ensure the specimen and test clevises are clean and free of dirt and lubrication.

9.2 Place the specimen in the test fixtures of the type shown in Fig. 1 and apply a small preload of 50 to 100 lb (220 to 440 N) to the specimen.

9.3 Mount a displacement gage on the specimen or fixtures to monitor the displacement of the specimen during testing.

9.4 *Testing*—Conduct the test so that the crosshead displacement is between 0.05 in./min (1.3 mm/min) and 0.10 in./min (2.5 mm/min). Monitor the displacement using a device similar to that described in 6.3. Record the force and displacement to determine the maximum force and energies required to fail the specimen. A typical test curve is shown in Fig. 5. The test should be stopped when the test force decreases to 1 to 2 % of the force range.

9.5 *Fracture Appearance and Manner*—The appearance of the fracture is valuable subsidiary information and shall be noted for each specimen. Representative types of fracture are shown in Fig. 6. Type A is considered “normal”; that is, the

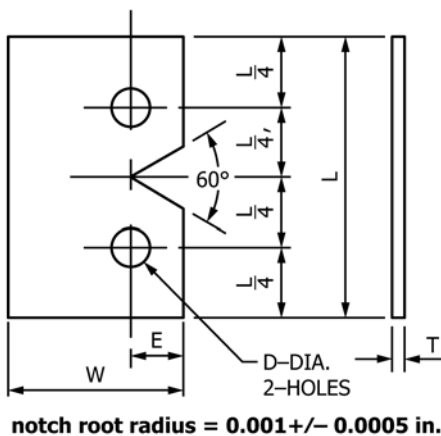

Type of Specimen	T	E	W	D	L
1	0.064	0.438	1.438	0.3125/0.3130	2¼
2	0.100	0.438	1.438	0.3125/0.3130	2¼
3	0.125	0.438	1.438	0.3125/0.3130	2¼
4	0.187	0.438	1.438	0.3125/0.3130	2¼
5	0.250	0.438	1.438	0.3125/0.3130	2¼

FIG. 2 Tear Test Specimen