

INTERNATIONAL
STANDARD

ISO
3302-1

First edition
1996-07-15

Rubber — Tolerances for products —

Part 1:

Dimensional tolerances

iTeh STANDARD PREVIEW

(standards.iteh.ai)

Caoutchouc — Tolérances pour produits —

Partie 1: Tolérances dimensionnelles

<https://standards.iteh.ai/catalog/standards/sist/2433e7d4-d7ce-40fd-b842-78d130ac7206/iso-3302-1-1996>



Reference number
ISO 3302-1:1996(E)

Foreword

ISO (the International Organization for Standardization) is a worldwide federation of national standards bodies (ISO member bodies). The work of preparing International Standards is normally carried out through ISO technical committees. Each member body interested in a subject for which a technical committee has been established has the right to be represented on that committee. International organizations, governmental and non-governmental, in liaison with ISO, also take part in the work. ISO collaborates closely with the International Electrotechnical Commission (IEC) on all matters of electrotechnical standardization.

Draft International Standards adopted by the technical committees are circulated to the member bodies for voting. Publication as an International Standard requires approval by at least 75 % of the member bodies casting a vote.

International Standard ISO 3302-1 was prepared by Technical Committee ISO/TC 45, *Rubber and rubber products*, Subcommittee SC 4, *Miscellaneous products*.

This edition of ISO 3302-1 cancels and replaces ISO 3302:1990, *Rubber — Dimensional tolerances for use with products*, of which it constitutes a technical revision, in particular in relation to table 1 (tolerances for mouldings).

ISO 3302 consists of the following parts, under the general title *Rubber — Tolerances for products*:

- Part 1: *Dimensional tolerances*
- Part 2: *Geometrical tolerances*

© ISO 1996

All rights reserved. Unless otherwise specified, no part of this publication may be reproduced or utilized in any form or by any means, electronic or mechanical, including photocopying and microfilm, without permission in writing from the publisher.

International Organization for Standardization
Case Postale 56 • CH-1211 Genève 20 • Switzerland

Printed in Switzerland

Introduction

Rubber products are subject to changes in their dimensions after processing and vulcanization. This may be due to a variety of factors, such as mould shrinkage or relaxation of die swell.

These changes should be determined and allowed for when designing such items as moulds and dies used in the manufacture of a given product.

The closer tolerance classes outlined in this specification should not be demanded unless required by the final application and should be restricted to those dimensions deemed to be critical. The greater the degree of accuracy demanded, the closer the control which must be exercised during manufacture, and hence the higher the costs.

When particular physical properties are required in the product, it may not always be possible to provide them in a mix which is capable of fabrication to close tolerances. It is advisable, in these circumstances, that consultation should take place between the interested parties. In general, softer vulcanizates (i.e. those of hardness below 50 IRHD — see ISO 48) need greater tolerances than harder ones.

<https://standards.iteh.ai/catalog/standards/sist/2433e7d4-d7ce-40fd-b842-78d130ac7206/iso-3302-1-1996>

iTeh STANDARD PREVIEW
This page intentionally left blank
(standards.iteh.ai)

ISO 3302-1:1996

<https://standards.iteh.ai/catalog/standards/sist/2433e7d4-d7ce-40fd-b842-78d130ac7206/iso-3302-1-1996>

Rubber — Tolerances for products —

Part 1: Dimensional tolerances

1 Scope

This part of ISO 3302 specifies classes of dimensional tolerances, and their values, for moulded, extruded and calendered solid rubber products. The relevant test methods necessary for the establishment of compliance with this International Standard are also specified.

The tolerances are primarily intended for use with vulcanized rubber but may also be suitable for products made of thermoplastic rubbers.

This part of ISO 3302 does not apply to precision toroidal sealing rings or to calendered composite products such as rubber-coated fabrics or products where a rubber coating is applied by the process of topping or skim coating.

2 Normative references

The following standards contain provisions which, through reference in this text, constitute provisions of this part of ISO 3302. At the time of publication, the editions indicated were valid. All standards are subject to revision, and parties to agreements based on this part of ISO 3302 are encouraged to investigate the possibility of applying the most recent editions of the standards listed below. Members of IEC and ISO maintain registers of currently valid International Standards.

ISO 3:1973, *Preferred numbers — Series of preferred numbers*.

iTeh STANDARD PREVIEW
(standards.iteh.ai)

ISO 48:1994, *Rubber, vulcanized or thermoplastic — Determination of hardness (hardness between 10 IRHD and 100 IRHD)*.

ISO 471:1995, *Rubber — Temperatures, humidities and times for conditioning and testing*.

ISO 2230:1973, *Vulcanized rubber — Guide to storage*.

ISO 4648:1991, *Rubber, vulcanized or thermoplastic — Determination of dimensions of test pieces and products for test purposes*.

3 Measurement of dimensions

3.1 General

For solid products, measurements of dimensions shall not be made until 16 h have elapsed after vulcanization, this minimum time being extended to 72 h in cases of dispute. Measurements shall be completed within 3 months after the date of despatch to the purchaser or before the product is put into use, whichever is the shorter time. Measurements shall be made at standard temperature, after conditioning (see ISO 471). Care shall be taken to ensure that the products are not subjected to adverse storage conditions (see ISO 2230) and that they are not distorted during measurement.

3.2 Test instruments

3.2.1 Depending on the circumstances, measurements shall be made using one or more of the following types of instrument:

3.2.1.1 For solid products, a **micrometer dial gauge**, the foot of which shall exert a pressure of $22 \text{ kPa} \pm 5 \text{ kPa}$ for rubber of hardness equal to or greater than 35 IRHD or of $10 \text{ kPa} \pm 2 \text{ kPa}$ for rubber of hardness less than 35 IRHD (see ISO 4648 and ISO 48).

3.2.1.2 A suitable optical measuring instrument.

3.2.1.3 Fixed gauges, for upper and lower limits appropriate to the dimensions being measured.

3.2.1.4 Other devices, including tape measures (with or without vernier), sliding calipers and micrometer calipers.

3.2.2 All instruments shall be capable of measuring the dimension with an error within the tolerances specified.

3.2.3 In all measurements intended to be comparative, the same measuring device shall be used.

4 Tolerances

For the purposes of this part of ISO 3302, nominal dimensions and tolerances are based on the R 5 and R 10 series of preferred numbers respectively (see ISO 3).

The dimensions of certain parameters of a particular product may not all require the application of the same class of tolerance. Dimensions of different parameters of the product on the same drawing may have different class tolerances applied to them. When drawings do not indicate a required class tolerance, the largest tolerance given in the related table shall be applied.

NOTES

1 Tolerances that are specified in this part of ISO 3302 in terms of a positive value and an equal negative value (e.g. $\pm 0,35$) may also be expressed in terms of unequal positive and negative values, providing the difference between the two values remains the same. For example, $\pm 0,35$ may also be expressed as $^{+0,2}_{-0,5}$ or $^{+0,7}_{-0}$, etc.

2 Special consideration of tolerances will be necessary for a vulcanizate with a low hardness and a high tensile strength (e.g. natural rubber gum vulcanizate).

5 Mouldings

5.1 General

The dimensional tolerances stated in this part of ISO 3302 may be wider than those used in some other engineering practice. The following considerations apply:

- a) All rubber shows some shrinkage when cooled after moulding, and allowance for this is made in the mould design. The amount of shrinkage is dependent on the rubber type and the mix used, but also varies from batch to batch of the same mix. Products made from some silicone rubbers, fluorocarbon elastomers and other special-purpose elastomers are subject to larger shrinkages; therefore tolerance classes M1 and M2 (see 5.2) are very difficult to obtain with these rubbers.
- b) Non-rubber parts bonded to the rubber will affect the shrinkage and, therefore, the practicable tolerances.
- c) Moulds are made in various ways depending on the type of product and accuracy demanded. In general, the product can be no more accurate than the mould, and the greater the degree of accuracy demanded, the more expensive become the moulds and their maintenance.
- d) Care shall be taken in applying the standard tolerances to products having wide sectional variations.
- e) In cases where the rubber product is unavoidably distorted during removal from the mould, the dimensions of the products may be affected, and special allowance may be needed.

5.2 Classification

This subclause establishes four classes of tolerance for fixed and closure dimensions (see 5.3) for products moulded in solid rubber, namely:

- a) Class M1 for precision mouldings. Such mouldings require precision moulds, fewer cavities per mould, close mix controls, etc., which results in high cost. Optical comparators or other, similar, measuring devices may be required to minimize distortion of the rubber by the measuring instrument. This type of part requires expensive control and inspection procedures.
- b) Class M2 for high-quality mouldings involving much of the close control required for class M1.

- c) Class M3 for good-quality mouldings.
- d) Class M4 for mouldings where dimensional control is non-critical.

5.3 Fixed dimensions and closure dimensions

In moulding a rubber product, more rubber is used than is required to fill the cavity, and the excess is flashed. This flash tends to prevent the mould sections from fully closing and thus affects the finished-part dimensions.

NOTE 3 For products moulded by transfer or injection, it is possible to regard all dimensions as fixed.

Two sets of tolerances, F and C, are given and are defined below.

5.3.1 fixed dimensions (F): Dimensions which are not affected by deforming influences like flash thickness or lateral displacement of different mould parts

(upper and lower parts or cores). See figure 1, dimensions l_1 , l_2 and l_3 .

5.3.2 closure dimensions (C): Dimensions which can be altered by variation in the flash thickness or lateral displacement of different mould parts. See figure 1, dimensions d_1 , d_2 , d_3 and h .

NOTE 4 The dimensions for F and C can only be tolerated insofar as they are independent of each other.

5.4 Tolerances

The tolerances to be applied shall be chosen, by agreement between the interested parties, from the classes of tolerance described in 5.2.

Standard tolerances are given in table 1. Fixed tolerances (F) are related by size to each dimension, but all closure tolerances (C) are determined by the largest closure dimension (h , see figure 1).

iTeh STANDARD PREVIEW (standards.iteh.ai)

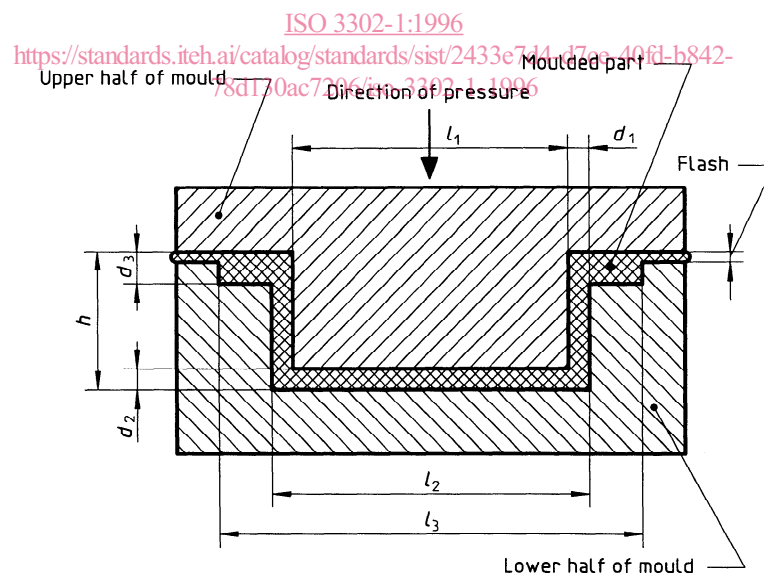

Figure 1 — Compression mould and moulded part (diagrammatic)

Table 1 — Tolerances for mouldings

Values in millimetres (unless indicated otherwise)

Nominal dimension		Class M1		Class M2		Class M3		Class M4
above	up to and including	F ±	C ±	F ±	C ±	F ±	C ±	F and C ±
0	4,0	0,08	0,10	0,10	0,15	0,25	0,40	0,50
4,0	6,3	0,10	0,12	0,15	0,20	0,30	0,50	0,70
6,3	10	0,10	0,15	0,20	0,20	0,40	0,60	0,80
10	16	0,15	0,20	0,20	0,25	0,50	0,80	1,00
16	25	0,20	0,20	0,25	0,35	0,60	1,00	1,30
25	40	0,20	0,25	0,35	0,40	0,80	1,30	1,60
40	63	0,25	0,35	0,40	0,50	1,00	1,60	2,0
63	100	0,35	0,40	0,50	0,70	1,30	2,0	2,5
100	160	0,40	0,50	0,70	0,80	1,30	2,0	2,5
160	—	0,3 %	0,4 %	0,5 %	0,7 %	0,8 %	1,3 %	1,5 %

6 Extrusions

EN2 high quality;

EN3 good quality.

6.1 General

Extruded rubber products require greater tolerances in manufacture than those produced by moulding since the rubber undergoes die swell and, during subsequent vulcanization, shrinkage and deformation usually occur.

Deformation can be reduced by the use of supports during vulcanization, the nature of the support depending on the section being produced, and the degree of control required. Such features determine the class of tolerance applicable to given dimensions.

In the case of certain synthetic rubbers, extrusion class E1 tolerances are not directly obtainable.

6.2 Classification

This subclause establishes 11 classes of tolerance for extrusions in solid rubber, related to particular ranges of dimensions, namely:

a) Three classes of tolerance on nominal cross-sectional dimensions of unsupported extrusions:

- E1 high quality;
- E2 good quality;
- E3 non-critical.

b) Three classes of tolerance on nominal cross-sectional dimensions of mandrel-supported extrusions:

- EN1 precision;

c) Two classes of tolerance (EG) on outside dimensions (nominal diameters) of surface-ground extrusions (tubing) together with two classes of tolerance (EW) on wall thickness of these extrusions:

EG1 and EW1 precision;

EG2 and EW2 good quality.

d) Three classes of tolerance (L) for the cut length of extrusions, and three classes of tolerance (EC) on the thickness of cut sections of extrusions:

L1 and EC1 precision;

L2 and EC2 good quality;

L3 and EC3 non-critical.

6.3 Tolerances

6.3.1 General

The tolerances to be applied shall be chosen, by agreement between the interested parties, from the classes of tolerance described in 6.2.

Standard tolerances are given in tables 2 to 7.

In any extruded cross-section, the dimensions of only two of the three variables (i.e. inside dimensions, outside dimensions and wall thickness) can be tolerated to control the dimensions of the cross-section.

6.3.2 Unsupported extrusions

The tolerances on the cross-sectional dimensions of unsupported extrusions are given in table 2.

For hollow extrusions or extrusions having a complex section, a certain amount of collapse may occur during vulcanization. It is possible to limit or prevent this collapse by putting the extrusions on mandrels or on formers. The amount of the permitted deformation of the section shall be stated by the purchaser.

6.3.3 Mandrel-supported extrusions

Vulcanization of hollow extrusions may be carried out on mandrels to achieve closer tolerances on internal dimensions than can be obtained without support. This can apply to tubing from which rings or washers are subsequently cut. Shrinkage usually occurs when the product is removed from the mandrel, so that the resulting size of the mandrel-supported dimension is smaller than the mandrel size. The dimension may, however, be larger should the positive tolerance for the mandrel exceed the shrinkage of the extrudate, and in this case both positive and negative tolerances will need to be applied.

The tolerances on internal dimensions of mandrel-supported extrusions are given in table 3. The positive tolerance is intended to cater for any tolerances that may apply to the mandrel itself and for this reason no change of tolerance in either direction is permitted for the internal dimension; the negative tolerances specified in table 3 shall not be increased.

All other dimensions shall be in accordance with table 2.

6.3.4 Surface-ground extrusions

6.3.4.1 The tolerances on the outside dimensions (usually diameter) of surface-ground extrusions (normally tubing) are given in table 4.

NOTE 5 These tolerances are also applicable to rings cut from surface-ground tubing.

6.3.4.2 The tolerances on the wall thickness of surface-ground extrusions (normally tubing) are given in table 5.

6.3.5 Cut lengths

The tolerances on the cut length of extrusions are given in table 6.

6.3.6 Cut sections

The tolerances on the thickness of cut sections (for example rings, washers, discs) are given in table 7.

NOTE 6 Tolerance classes EC1 and EC2 can be obtained only for lathe-cut sections.

Table 2 — Tolerances on cross-sectional dimensions of unsupported extrusions

Values in millimetres

Nominal dimension		Class E1 ±	Class E2 ±	Class E3 ±
above	up to and including			
0	1,5	0,15	0,25	0,40
1,5	2,5	0,20	0,35	0,50
2,5	4,0	0,25	0,40	0,70
4,0	6,3	0,35	0,50	0,80
6,3	10,0	0,40	0,70	1,00
10	16	0,50	0,80	1,30
16	25	0,70	1,00	1,60
25	40	0,80	1,30	2,00
40	63	1,00	1,60	2,50
63	100	1,30	2,00	3,20