



Designation: **D6775 – 02 (Reapproved 2011) D6775 – 13**

Standard Test Method for Breaking Strength and Elongation of Textile Webbing, Tape and Braided Material¹

This standard is issued under the fixed designation D6775; the number immediately following the designation indicates the year of original adoption or, in the case of revision, the year of last revision. A number in parentheses indicates the year of last reapproval. A superscript epsilon (ϵ) indicates an editorial change since the last revision or reapproval.

1. Scope

1.1 This test method covers the determination of the breaking strength and elongation of textile webbing, tape and braided materials using a split-drum type specimen clamp.

1.2 This test method is limited to materials with a maximum width of 90 mm (3.5 in.) and a maximum breaking strength of no more than ~~89000N~~ 89000 N (20000 lb).

1.3 The values stated in either SI units or U.S. Customary units are to be regarded separately as standard. Within the text, the U.S. Customary units are given in parentheses. The values stated in each system are not exact equivalents; therefore, each system shall be used independently of the other.

1.4 *This standard does not purport to address all of the safety concerns, if any, associated with its use. It is the responsibility of the user of this standard to establish appropriate safety and health practices and determine the applicability of regulatory limitations prior to use.*

2. Referenced Documents

2.1 *ASTM Standards:*²

[D76 Specification for Tensile Testing Machines for Textiles](#)

[D123 Terminology Relating to Textiles](#)

[D1776 Practice for Conditioning and Testing Textiles](#)

[D4848 Terminology Related to Force, Deformation and Related Properties of Textiles](#)

[D4850 Terminology Relating to Fabrics and Fabric Test Methods](#)

3. Terminology

3.1 For definitions of terms related to force and deformation used in this test method, refer to Terminology [D4848](#). For definitions of other terms related to textiles used in this standard, refer to Terminology [D123](#), and [D4850](#).

4. Summary of Test Method

4.1 A specimen is clamped in a tensile testing machine and extended to rupture. The breaking force is determined from a force-elongation curve or with an interfaced computer. Elongation is determined by calculating the difference between bench marks before the application of a force and at a specified force.

5. Significance and Use

5.1 This test method can be used for acceptance testing of commercial shipments but comparisons should be made with caution because estimates of between-laboratory precision are incomplete.

5.1.1 If there are differences of practical significance between reported test results for two laboratories (or more), comparative tests should be performed to determine if there is a statistical bias between them, using competent statistical assistance. As a minimum, use samples for such comparative tests that are as homogeneous as possible, drawn from the same lot of material as the samples that resulted in disparate results during initial testing, and randomly assigned in equal numbers to each laboratory. The test results from the laboratories involved should be compared using a statistical test for unpaired data, at a probability level chosen

¹ This test method is under the jurisdiction of ASTM Committee [D13](#) on Textiles and is the direct responsibility of Subcommittee [D13.60](#) on Fabric Test Methods, Specific. Current edition approved ~~May 1, 2011~~ July 1, 2013. Published ~~July 2011~~ August 2013. Originally approved in 2002. Last previous edition approved in ~~2007~~ 2011 as [D6775 – 02\(2007\)\(2011\)](#). DOI: ~~10.1520/D6775-02R11~~ 10.1520/D6775-13.

² For referenced ASTM standards, visit the ASTM website, www.astm.org, or contact ASTM Customer Service at service@astm.org. For *Annual Book of ASTM Standards* volume information, refer to the standard's Document Summary page on the ASTM website.

prior to the testing series. If bias is found, either its cause must be found and corrected, or future test results for that material must be adjusted in consideration of the known bias.

5.2 Elongation is an indication of the ability of a fiber to absorb energy. The elongation of textile materials must be great enough to withstand strains experienced in processing and end use, and to absorb the energies of applied forces repeatedly.

6. Apparatus³

6.1 *Tensile Testing Machine*, CRE-type, conforming to Specification D76 with respect to force indication, working range, capacity and verification of recorded elongation, and designed for operation at a pulling speed of 75 ± 25 mm/min (3 ± 1 in./min).

6.2 *Clamping Assembly*, consisting of an upper and lower clamp, each a split-drum type, as shown in Fig. 1 and Fig. 2.

6.3 *Computer or Microprocessor*, interfaced, with automatic data gathering system, including photo or electronic instruments to measure elongation. (Optional.)

7. Sampling, Test Specimens, and Test Units

7.1 *Lot Sample*—Take a lot sample as directed in the applicable material specification. In absence of such a specification randomly select five rolls or pieces to constitute the lot sample.

7.2 *Laboratory Sampling Unit, as produced material*—As a laboratory sampling unit take one piece of full-width webbing, tape or braid that is at least 1.4 m (1.5 yd) in length from each roll or piece in the lot sample.

7.2.1 For thick specimens, longer specimens may be required to maintain the specified gage length and to ensure the specimen is completely in the clamps.

7.2.2 When testing after abrasion is required, as a laboratory sampling unit, take one piece of full-width webbing, tape or braid that is at least 2.8 m (3.0 yd) in length from each roll or piece in the lot sample (see 7.2.1).

7.3 *Test Specimens, as produced material*—From each laboratory sampling unit, cut 1 test specimen full-width and at least 1.4 m (1.5 yd) in length (see 7.2.1).

7.3.1 When testing after abrasion is required, from each laboratory sampling unit, cut 2 test specimens full width and at least 1.4 m (1.5 yd) in length (see 7.2.1). Mark one specimen “A” for abraded and the other “U” for unabraded.

³ Apparatus and clamps are commercially available.

(https://standards.iteh.ai)
Document Preview

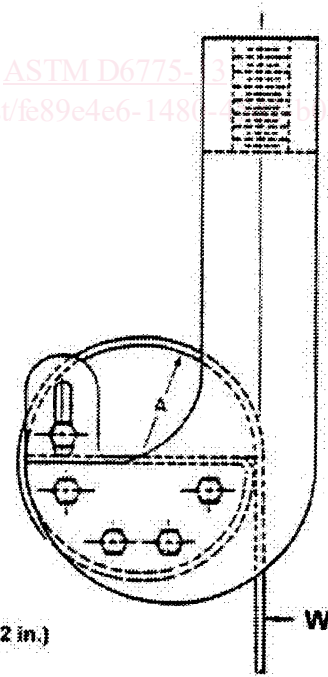

A = 2.5 - 5.0 cm (1 - 2 in.)

TEST JAWS FOR HIGH STRENGTH TEXTILES

FIG. 1 Side View of Clamping Assembly

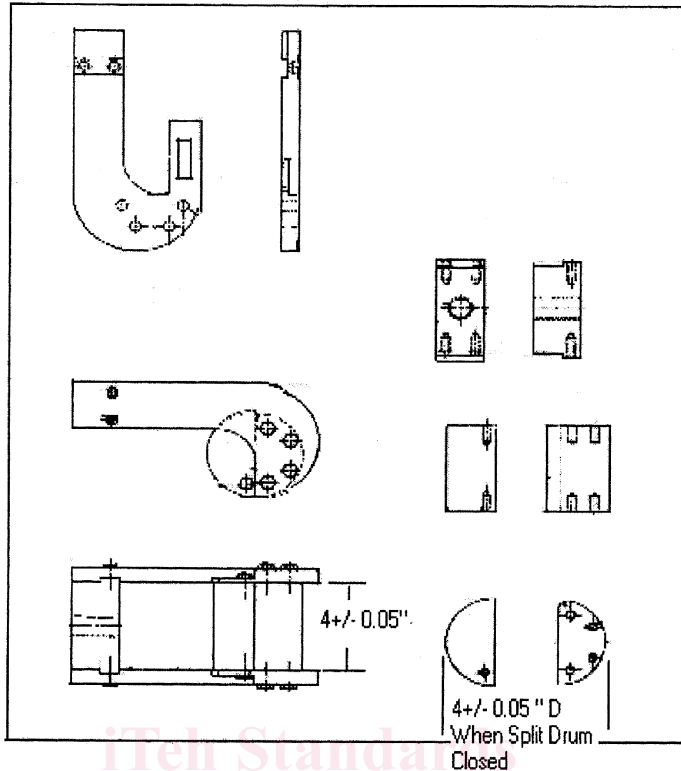

FIG. 2 Example of Clamping Assembly

7.4 When the lot or shipment consist of less than 5 rolls or pieces, randomly select 5 test specimens for each condition of test, that represent all rolls or pieces in the lot or shipment.

7.5 Ensure specimens are free of folds, creases, or wrinkles. Avoid getting oil, water, grease, etc. on the specimens when handling.

NOTE 1—An adequate specification or other agreement between the purchaser and the supplier requires taking into account the variability between shipping units, between packages or ends within a shipping unit, and between specimens from a single package to provide a sampling with a meaningful producer's risk, consumer's risk, acceptable quality level and limiting quality level.

8. Preparation of Apparatus

8.1 Prepare and verify the calibration of the tensile testing machine as directed in the manufacturer's instructions and Specification D76.

8.2 Set up and adjust the CRE-type tensile testing machine as follows:

8.2.1 Ensure that the clamps are positioned such that they are facing opposite of each other with the upper clamp facing front and the lower clamp facing back. Set the distance between clamps, (gage length) to 250 ± 10 mm (10 ± 0.5 in.), center to center of the drums at the split.

8.2.2 Use a force measuring system such that the breaking force will fall between 15 and 85 percent of its full-scale capacity.

8.2.3 Set the crosshead speed to 75 ± 25 mm/min (3 ± 1 in./min).

8.2.4 When using an interfaced computer or microprocessor, set parameters to obtain selected properties using supplier's directions and Specification D76.

9. Conditioning

9.1 Condition the test specimens to moisture equilibrium for testing in the standard atmosphere for testing textiles in accordance with Practice D1776 or, if applicable, in the specified atmosphere in which the testing is to be performed.

9.2 In the event of dispute concerning the results of tests that may be affected by the moisture content, test specimen(s) shall be preconditioned by bringing them to approximate moisture equilibrium in the standard atmosphere for preconditioning textiles in accordance with Practice D1776.

10. Procedure

10.1 Test the relaxed specimens in the standard atmosphere for testing textiles.

NOTE 2—The force measuring system should be zeroed prior to running any specimens and periodically during the course of the test, particularly if