



Standard Test Methods for Determining Effects of Large Hydrocarbon Pool Fires on Structural Members and Assemblies¹

This standard is issued under the fixed designation E1529; the number immediately following the designation indicates the year of original adoption or, in the case of revision, the year of last revision. A number in parentheses indicates the year of last reapproval. A superscript epsilon (ϵ) indicates an editorial change since the last revision or reapproval.

INTRODUCTION

The performance of structural members and assemblies exposed to fire conditions resulting from large, free-burning (that is, outdoors), fluid-hydrocarbon-fueled pool fires is of concern in the design of hydrocarbon processing industry (HPI) facilities and other facilities subject to these types of fires. In recognition of this unique fire protection problem, it is generally required that critical structural members and assemblies be of fire-resistant construction.

Historically, such requirements have been based upon tests conducted in accordance with Test Methods E119, the only available standardized test for fire resistant construction. However, the exposure specified in Test Methods E119 does not adequately characterize large hydrocarbon pool fires. Test Methods E119 is used for representation of building fires where the primary fuel is solid in nature, and in which there are significant constraints on the movement of air to the fire, and the combustion products away from the fire (that is, through doors, windows). In contrast, neither condition is typical of large hydrocarbon pool fires (see Appendix X1 on Commentary).

One of the most distinguishing features of the pool fire is the rapid development of high temperatures and heat fluxes that can subject exposed structural members and assemblies to a thermal shock much greater than that associated with Test Methods E119. As a result, it is important that fire resistance requirements for HPI assemblies of all types of materials be evaluated and specified in accordance with a standardized test that is more representative of the anticipated fire conditions. Such a standard is found in the test methods herein.

1. Scope

1.1 The test methods described in this fire-test-response standard are used for determining the fire-test response of columns, girders, beams or similar structural members, and fire-containment walls, of either homogeneous or composite construction, that are employed in HPI or other facilities subject to large hydrocarbon pool fires.

1.2 It is the intent that tests conducted in accordance with these test methods will indicate whether structural members of assemblies, or fire-containment wall assemblies, will continue to perform their intended function during the period of fire exposure. These tests shall not be construed as having determined suitability for use after fire exposure.

1.3 These test methods prescribe a standard fire exposure for comparing the relative performance of different structural and fire-containment wall assemblies under controlled laboratory conditions. The application of these test results to predict the performance of actual assemblies when exposed to large pool fires requires a careful engineering evaluation.

1.4 These test methods provide for quantitative heat flux measurements during both the control calibration and the actual test. These heat flux measurements are being made to support the development of design fires and the use of fire safety engineering models to predict thermal exposure and material performance in a wide range of fire scenarios.

1.5 These test methods are useful for testing other items such as piping, electrical circuits in conduit, floors or decks, and cable trays. Testing of these types of items requires development of appropriate specimen details and end-point or failure criteria. Such failure criteria and test specimen descriptions are not provided in these test methods.

1.6 *Limitations*—These test methods do not provide the following:

¹ These test methods are under the jurisdiction of ASTM Committee E05 on Fire Standards and are the direct responsibility of Subcommittee E05.11 on Fire Resistance. Current edition approved Sept. 1, 2010/July 1, 2013. Published December 2010/August 2013. Originally approved in 1993. Last previous edition approved in 2006/2010 as E1529—06/E1529—10. DOI: 10.1520/E1529-10/10.1520/E1529-13.

- 1.6.1 Full information on the performance of assemblies constructed with components or of dimensions other than those tested.
- 1.6.2 An evaluation of the degree to which the assembly contributes to the fire hazard through the generation of smoke, toxic gases, or other products of combustion.
- 1.6.3 Simulation of fire behavior of joints or connections between structural elements such as beam-to-column connections.
- 1.6.4 Measurement of flame spread over the surface of the test assembly.
- 1.6.5 Procedures for measuring the test performance of other structural shapes (such as vessel skirts), equipment (such as electrical cables, motor-operated valves, etc.), or items subject to large hydrocarbon pool fires, other than those described in 1.1.
- 1.6.6 The erosive effect that the velocities or turbulence, or both, generated in large pool fires has on some fire protection materials.
- 1.6.7 Full information on the performance of assemblies at times less than 5 min because the rise time called out in Section 5 is longer than that of a *real* fire.
- 1.7 These test methods do not preclude the use of a *real* fire or any other method of evaluating the performance of structural members and assemblies in simulated fire conditions. Any test method that is demonstrated to comply with Section 5 is acceptable.
- 1.8 The values stated in inch-pound units are to be regarded as standard. The values given in parentheses are mathematical conversions to SI units that are provided for information only and are not considered standard.
- 1.9 *This standard is used to measure and describe the response of materials, products, or assemblies to heat and flame under controlled conditions, but does not by itself incorporate all factors required for fire hazard or fire risk assessment of the materials, products, or assemblies under actual fire conditions.*
- 1.10 *This standard does not purport to address all of the safety concerns, if any, associated with its use. It is the responsibility of the user of this standard to establish appropriate safety and health practices and determine the applicability of regulatory limitations prior to use.*
- 1.11 The text of this standard references notes and footnotes which provide explanatory information. These notes and footnotes (excluding those in tables and figures) shall not be considered as requirements of the standard.

2. Referenced Documents

2.1 ASTM Standards:²

[B117 Practice for Operating Salt Spray \(Fog\) Apparatus](#)

[D822 Practice for Filtered Open-Flame Carbon-Arc Exposures of Paint and Related Coatings](#)

[E119 Test Methods for Fire Tests of Building Construction and Materials](#)

[E176 Terminology of Fire Standards](#)

[E457 Test Method for Measuring Heat-Transfer Rate Using a Thermal Capacitance \(Slug\) Calorimeter](#)

[E459 Test Method for Measuring Heat Transfer Rate Using a Thin-Skin Calorimeter](#)

[E511 Test Method for Measuring Heat Flux Using a Copper-Constantan Circular Foil, Heat-Flux Transducer](#)

[E814 Test Method for Fire Tests of Penetration Firestop Systems](#)

[E2683 Test Method for Measuring Heat Flux Using Flush-Mounted Insert Temperature-Gradient Gages](#)

2.2 Code of Federal Regulations:³

[46 CFR 164.007 Structural Insulations](#)

2.3 IMO Documents:⁴

[IMO A754](#)

2.4 ISO Standard:⁵

[ISO 834-1 Fire Resistance Tests – Elements of Building Construction – Part 1: General Requirements](#)

3. Terminology

3.1 *Definitions*—Refer to Terminology [E176](#) for definitions of terms used in these test methods.

3.2 *Definitions of Terms Specific to This Standard:*

3.2.1 *total cold wall heat flux*—the heat flux that would be transferred to an object whose temperature is 70°F (21°C).

4. Summary of Test Methods

4.1 A standard fire exposure of controlled extent and severity is specified. The test setup will provide an average total cold wall heat flux on all exposed surfaces of the test specimen of 50 000 Btu/ft²·h ± 2500 Btu/ft²·h (158 kW/m² ± 8 kW/m²). The heat flux shall be attained within the first 5 min of test exposure and maintained for the duration of the test. The temperature of the

² For referenced ASTM standards, visit the ASTM website, www.astm.org, or contact ASTM Customer Service at service@astm.org. For *Annual Book of ASTM Standards* volume information, refer to the standard's Document Summary page on the ASTM website.

³ Available from Standardization Documents Order Desk, Bldg. 4 Section D, 700 Robbins Ave., Philadelphia, PA 19111-5094, Attn: NPODS.

⁴ Available from the International Maritime Organization (IMO), Environmental Standards Division (CG-5224), U.S. Coast Guard Headquarters, 2100 Second Street SW, Washington, DC 20593; http://www.uscg.mil/environmental_standards/

⁵ Available from American National Standards Institute (ANSI), 25 W. 43rd St., 4th Floor, New York, NY 10036, <http://www.ansi.org>.

environment that generates the heat flux of procedures in 6.2 shall be at least 1500°F (815°C) after the first 3 min of the test and shall be between 1850°F (1010°C) and 2150°F (1180°C) at all times after the first 5 min of the test. Performance is defined as the time period during which structural members or assemblies will continue to perform their intended function when subjected to fire exposure. The results are reported in terms of time increments such as ½ h, ¾ h, 1 h, 1½ h, etc.

4.1.1 These test methods require quantitative measurements of thermal exposure during both furnace calibration and actual testing.

4.1.2 These test methods are cited as the “Standard Large Hydrocarbon Pool Fire Tests.”

5. Significance and Use

5.1 These test methods are intended to provide a basis for evaluating the time period during which a beam, girder, column, or similar structural assembly, or a nonbearing wall, will continue to perform its intended function when subjected to a controlled, standardized fire exposure.

5.1.1 In particular, the selected standard exposure condition simulates the condition of total continuous engulfment of a member or assembly in the luminous flame (fire plume) area of a large free-burning-fluid-hydrocarbon pool fire. The standard fire exposure is basically defined in terms of the total flux incident on the test specimen together with appropriate temperature conditions. Quantitative measurements of the thermal exposure (total heat flux) are required during both furnace calibration and actual testing.

5.1.2 It is recognized that the thermodynamic properties of free-burning, hydrocarbon fluid pool fires have not been completely characterized and are variable depending on the size of the fire, the fuel, environmental factors (such as wind conditions), the physical relationship of the structural member to the exposing fire, and other factors. As a result, the exposure specified in these test methods is not necessarily representative of all the conditions that exist in large hydrocarbon pool fires. The specified standard exposure is based upon the best available information and testing technology. It provides a basis for comparing the relative performance of different assemblies under controlled conditions.

5.1.3 Any variation to construction or conditions (that is, size, method of assembly, and materials) from that of the tested assembly is capable of substantially changing the performance characteristics of the assembly.

5.2 Separate procedures are specified for testing column specimens with and without an applied superimposed load.

5.2.1 The procedures for testing loaded columns stipulate that the load shall be applied axially. The applied load is to be the maximum load condition allowed under nationally recognized structural design criteria unless limited design criteria are specified and a corresponding reduced load applied.

5.2.2 The procedure for testing unloaded steel column specimens includes temperature limits. These limits are intended to define the temperature above which a steel column with an axially applied design allowable load would fail structurally.

~~NOTE 1—The procedure for unloaded specimens also provides for the testing of other than steel columns provided that appropriate acceptance criteria have been established.~~

5.2.3 The procedure for unloaded specimens also provides for the testing of other than steel columns provided that appropriate acceptance criteria have been established.

5.3 Separate procedures are also specified for testing beam assemblies with and without an applied superimposed load.

5.3.1 The procedure for testing loaded specimens stipulates that the beam shall be simply supported. Application of restraint against longitudinal thermal expansion depends on the intended use, as specified by the customer. The applied load is intended to be the allowable design load permitted for the beam as determined in accordance with accepted engineering practice.

5.3.2 The procedure for testing unloaded beams includes temperature limits for steel. These limits are to define the temperature above which a simply supported, unrestrained beam would fail structurally if subjected to the allowable design load. The procedure for unloaded specimens also provides for the testing of other than steel and reinforced concrete beams provided that appropriate acceptance criteria have been established.

5.3.3 It is recognized that beam assemblies that are tested without load will not deflect to the same extent as an identical assembly tested with load. As a result, tests conducted in accordance with the unloaded beam procedure are not intended to reflect the effects of crack formation, dislodgement of applied fire protection materials, and other factors that are influenced by the deflection of the assembly.

5.4 A separate procedure is specified for testing the fire-containment capability of a wall/bulkhead/partition, etc. Acceptance criteria include temperature rise of nonfire exposed surface, plus the ability of the wall to prohibit passage of flames or hot gases, or both.

5.5 In most cases, the structural assemblies that will be evaluated in accordance with these test methods will be located outdoors and subjected to varying weather conditions that are capable of adversely affecting the fire endurance of the assembly. A program of accelerated weathering followed by fire exposure is described to simulate such exposure.

5.6 These test methods provide for quantitative heat flux measurements to support the development of design fires and the use of fire safety engineering models to predict thermal exposure and material performance in a wide range of fire scenarios.

CONTROL OF FIRE TEST

6. Fire Test Exposure Conditions

6.1 Expose the test specimen to heat flux and temperature conditions representative of total continuous engulfment in the luminous flame regime of a large free-burning fluid-hydrocarbon-fueled pool fire. See **Appendix X1**, which describes measurements in intermediate to large scale pool fires with calorimeters of different sizes and shapes, for the rationale used in the selection of the temperatures and heat flux specifications. Essential conditions are specified in **6.2** and **6.3**. Use calibration assemblies to demonstrate that the required heat flux and temperature levels are generated in the test facility.

6.2 After the first 5 min, the test setup will provide an average total cold wall heat flux (**6.2.1**) on all exposed surfaces of the test specimen of $50\,000 \text{ Btu/ft}^2\cdot\text{h} \pm 2500 \text{ Btu/ft}^2\cdot\text{h}$ ($158 \text{ kW/m}^2 \pm 8 \text{ kW/m}^2$). Adjust the flow of fuel and air, or vary other parameters, or both, within the individual test facility as necessary to achieve the specified setup. Attain the cold wall heat flux of $50\,000 \text{ Btu/ft}^2\cdot\text{h}$ within the first 5 min of test exposure; maintain it for the duration of the test. (See **7.1** through **7.3** for measurement and control details.)

6.2.1 In all cases in these test methods, the heat flux values cited are total cold wall heat fluxes, where the wall temperature is 50°C .

6.3 The temperature of the environment that generates the heat flux specified in **6.2** shall be at least 1500°F (815°C) after the first 3 min of the test and shall be between 1850°F (1010°C) and 2150°F (1180°C) at all times after the first 5 min of the test. (See **9.1-9.4** for measurement and control details.)

6.4 Continue the fire-endurance test until the specified conditions of acceptance are exceeded or until the specimen has withstood the fire exposure for a period equal to that for which classification is being sought. Continue the test beyond the time at which the specified conditions of acceptance are exceeded, when the purpose in doing so is to obtain additional performance data.

7. Heat Flux Measurements

7.1 Measure the total heat flux as specified in **6.2** using both calibration and fire-resistance (actual) tests.

7.2 The sensors to be used for this measurement during calibration tests are (1) water-cooled Schmidt-Boelter Gauges (thermopile design) or Gardon Gauges (aka Circular Foil Heat Flux Gauges - differential thermocouple design) or (2) Directional Flame Thermometers, which are uncooled (passive) sensors.

7.2.1 When using water-cooled heat flux sensors, the temperature of the cooling water shall be above the dew point in the furnace (50°C is usually sufficient). Otherwise, large uncertainties will result due to condensation. Gardon Gauges are more sensitive to this error than Schmidt-Boelter Gauges.

7.2.2 Because the radiative sensitivity of Gardon Gauges is up to 25 % greater than the convective sensitivity, they shall not be used in this test method unless the gauge rating is at least 8 times greater than the specified total heat flux.

NOTE 1—Water-cooled heat flux gauges are discussed in **Annex A1** for Gardon Gauges. See Test Method **E511** (Subcommittee E21.08). E21.08 is developing a standard for Schmidt-Boelter Gauges.

7.2.3 When Directional Flame Thermometers (DFTs) are used, they shall be fabricated to meet the specifications contained in **Annex A2**. DFTs utilize two thermocouples. Methods for analyzing DFT data to obtain the heat flux history are given in **Annex A2**.

7.2.4 For columns or beams, the heat flux measurements will be made with a calibration assembly mounted in the appropriate orientation. The calibration assembly is to be fabricated from noncombustible materials. The dimensions and instrumentation are shown in **Fig. 1**.⁶

7.2.5 For fire-containment walls, the heat flux measurements will be made with a calibration assembly with a minimum of 5 points as shown in **Fig. 2**.

7.2.6 The sampling rate for all heat flux and DFT plate temperature measurements is required to be 1 Hz (1 s interval) to utilize certain data analysis tools; it is suggested that all measurements be made with a 1 s sampling rate.

7.2.7 All measurements made within a 1 s interval (that is, recorded time ± 0.5 s) shall be considered as having been made at the same time.

7.3 Directional Flame Thermometers (DFTs) shall be used during actual fire-resistance tests. They shall be fabricated to meet the specifications contained in **Annex A2**. DFTs utilize two thermocouples. Methods for analyzing DFT data to obtain the heat flux history are given in **Annex A2**.

7.4 At all times after the first 5 min of a calibration or fire endurance test, the total heat flux shall be:

7.4.1 At any one point, between $37\,500$ and $62\,500 \text{ Btu/ft}^2\cdot\text{h}$ (118 to 197 kW/m^2). That is, $50\,000 \text{ Btu/ft}^2\cdot\text{h}$ (158 kW/m^2) ± 25 %).

⁶ The calibration assembly design shown in **Fig. 1** is similar to one developed by Underwriters Laboratories for their test method UL 1709 and is used with permission. This test method does not require the use of an exact duplicate of the Underwriters calibration assembly.

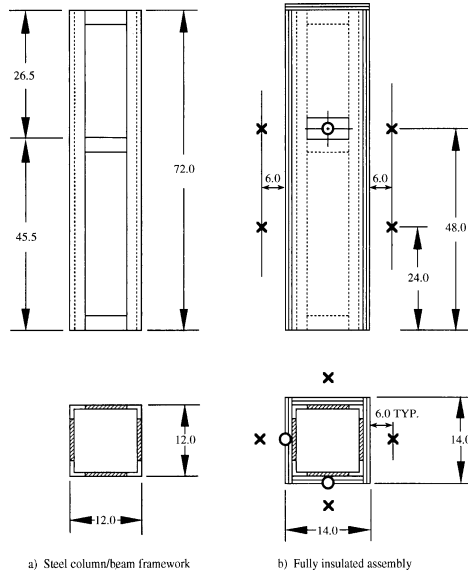

NOTE 1—O represents total heat flux sensor; X a gas temperature sensor.
 NOTE 2—Heat flux measurements are required on two faces of the column.
 NOTE 3—Temperature measurements are required on all faces.
 NOTE 4—All dimensions are in inches.

FIG. 1 Calibration Assembly for Beams and Columns

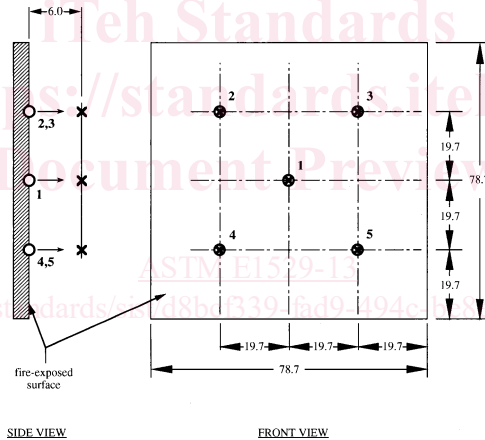

NOTE 1—O denotes site of heat flux measurement, X a gas temperature sensor.
 NOTE 2—Arrow denotes viewing direction of heat flux sensor.
 NOTE 3—All dimensions are in inches.

FIG. 2 Calibration Assembly for Fire-Containment Walls

7.4.2 For the average of the total number of measurement sites, between 47 500 and 52 500 Btu/ft²·h (50 000 Btu/ft²·h (158 kW/m²) ± 5 %.

8. Furnace Pressure Measurement

8.1 When testing any assembly that forms part of the wall of a test furnace (for example, walls, ceilings, floors, bulkheads, decks, doors, etc.), the furnace pressure shall be measured. The procedure is adapted from the differential pressure section of Test Method E814.

8.2 Measure the gauge pressure at three points 0.78 in. (20 mm) from the surface and located as follows:

8.2.1 *Vertical Surfaces*, at the center and quarter points on the vertical center line.

8.2.2 *Horizontal Surfaces*, at the center and quarter points on the longitudinal center line.

8.3 The pressure measuring probe tips shall be as shown in Fig. 3; this design is identical to the one shown in Fig. 4 of Test Method E814. The probe tips are to be manufactured from stainless steel or other suitable material.

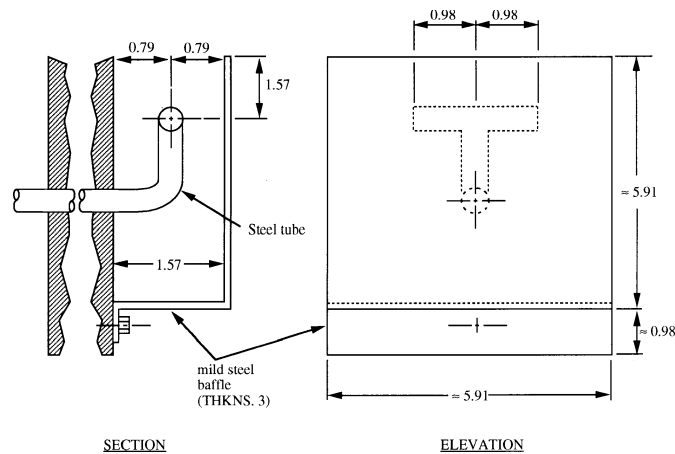

FIG. 3 Static Pressure-Measuring Device Dimensions in Millimetres

8.4 Measure the pressure by means of a manometer or equivalent transducer. The manometer or transducer shall be capable of reading 0.01 in. H₂O (2.5 Pa) increments with a measurement precision of 0.005 in. H₂O (12.5 Pa).

9. Furnace Measurements – Furnace (Gas) Temperature and Thermal Exposure

9.1 *Furnace Temperature*—Measure the temperature of the gases adjacent to and impinging on the calibration or test specimens, as specified in 6.3. Mineral-Insulated, Metal-Sheathed (MIMS) thermocouples shall be used. Use Inconel-sheathed, 0.25-in. outside diameter (OD), Type K, (Chromel-Alumel) thermocouples. The time constant of the MIMS thermocouple assemblies shall be less than 60 s in air flowing at 65 ft/s (20 m/s). Use standard calibration thermocouples with an accuracy of $\pm 0.75\%$. A minimum length of 20 diameters (125 mm) of the sheathed junction end of the thermocouple shall be mounted parallel to the surface of the test specimen.

9.2 Obtain the gas temperature from the readings of not less than five thermocouples for a nonbearing wall specimen, and not less than eight thermocouples for a column or beam specimen. The thermocouples shall be symmetrically disposed and distributed to show the temperatures of the environment near all parts of the specimen.

9.2.1 For columns and beams, the thermocouple junction shall be placed 6 in. (152 mm) away from the exposed faces of the specimen at the beginning of the test, and during the test shall not touch the specimen as a result of specimen growth or deflection.

9.2.2 In the case of fire-containment walls, the thermocouple junctions shall be placed 6 in. (152 mm) away from the exposed face of the specimen at the beginning of the test, and shall not touch the specimen during the test as a result of specimen growth or deflection.

9.3 Measurements of the gas temperature will be made with a maximum sampling interval of 10 s at each required measurement site. Data recorded within ± 10 s will satisfy the minimum requirements for calibration and control called out in Section 6.

9.4 At all times after the first 5 min of the test, the average gas temperature shall be between 1850°F (1010°C) and 2150°F (1180°C)

9.5 *Thermal Exposure*—To obtain total thermal exposure in these test methods, Directional Flame Thermometers (DFT) shall be used in both calibration and testing to provide quantitative heat flux measurements.

NOTE 2—Annex A2 provides specifications on the fabrication and use of DFTs. Appendix X2 explains the need for quantitative measurements and the rationale for selecting DFTs.

9.6 During a test run, one DFT will be mounted 6 in. (152 mm) from and parallel to the test unit wall of the furnace or 6 in. (152 mm) in front of one side of a column unit. A second DFT will be mounted 6 in. (152 mm) in front of the calibration unit during calibration runs.

9.7 Measurements of the DFT plate temperatures will be made with a sampling interval of 1 s. This is required for using the Inverse Filter Functions to calculate heat flux and thermal exposure.

10. Test Facility Design

10.1 These test methods specify the environment to which a specimen shall be exposed, but do not specify test facility design. This approach was taken for several reasons:

- 10.1.1 It is consistent with the approach of Test Methods E119,
- 10.1.2 It is important not to inhibit the creativity of experimenters in achieving the specified test environment, and
- 10.1.3 It is not desired to eliminate any existing facilities (or modification of them) or to eliminate the use of an actual fire *a priori*.

11. Calibration and Control of Furnace Type Test Facilities

11.1 If the test facility is of the furnace type, use the measurement and control procedures described in 11.2-11.6.

11.2 Calibration runs shall meet the following configurational and procedural criteria:

11.2.1 During all calibration runs, an instrumented calibration specimen shall be in place during the entire test. The calibration specimen shall be fabricated of noncombustible materials and shall be as follows:

11.2.1.1 For columns and beams, the box shape of Fig. 1, or its equivalent, oriented in the same position and inclination (for example, vertical or horizontal) as the subsequent materials test specimen would be.

11.2.1.2 For fire-containment wall specimens, the calibration specimen shall consist of 25 mm of ceramic insulating board⁷ facing the fire. The board shall be suitably supported in a frame, and if necessary, its backface (that is, nonfire-exposed surface) shall be insulated with inorganic blanket insulation such that the temperature of the backface of the entire (composite) specimen does not exceed the criteria of 17.6.2.

11.2.2 Instrument the calibration specimen to make measurements that are specified as follows:

11.2.2.1 *Total Heat Flux*—See 7.1 through 7.4.

11.2.2.2 *Gas Temperature*—See 9.1-9.4 and *Thermal Exposure*, see 9.5-9.7.

11.2.3 The time duration of the calibration run shall be:

11.2.3.1 At least as long as the longest subsequent materials test for which it shall apply, or

11.2.3.2 Until the test facility has reached a steady condition such that the average cold wall heat flux and the average gas temperature are within $\pm 5\%$ of the specified values over a continuous period of 15 min.

11.3 A successful calibration run shall meet the following criteria:

11.3.1 *For Total Heat Flux*—See 6.2 and Section 7.

11.3.2 *For Gas Temperature and Thermal Exposure*—See 6.3 and Section 9.

11.4 A furnace type facility shall be considered calibrated after an initial test that meets the requirements of 11.2 and 11.3.

11.5 After the initial calibration, recalibrate the test facility if any repair or modification is made to the heat generation, heat retention, flow or other characteristics of the furnace that is capable of affecting the initial calibration. Between calibrations, record any repairs, modifications, or maintenance made to the facility.

11.6 Once the test facility has been successfully calibrated, materials for testing shall be subjected to a fire environment simulated by reproducing the time-temperature curves recorded during the furnace calibration.

11.6.1 The accuracy of the furnace control shall be such that:

11.6.1.1 The area under the integrated heat-flux curve developed from Directional Flame Thermometer measurements of 9.1-9.3 is within 10 % of the corresponding curve developed in the furnace calibration for tests of $\frac{1}{2}$ h or less duration, within 7.5 % for those over $\frac{1}{2}$ h and not more than 1 h, and within 5 % for tests exceeding 1 h in duration.

11.6.1.2 The area under the time-temperature curve of the average of the gas temperature measurements of 9.1-9.3 is within 10 % of the corresponding curve developed in the furnace calibration for tests of $\frac{1}{2}$ h or less duration, within 7.5 % for those over $\frac{1}{2}$ h and not more than 1 h, and within 5 % for tests exceeding 1 h in duration.

TEST CONFIGURATIONS

12. Test Specimen

12.1 The test specimen shall be representative of the construction for which classification is desired as to materials, workmanship, and details such as the dimensions of various components. Build the test specimen under conditions representative of those encountered in actual construction to the extent possible. Determine the physical properties of the materials and components used in the construction of the test specimen where possible.

12.2 For fire-protected steel columns and beams, both the weight (w) and heated perimeter (d) of the steel member significantly influence fire endurance as determined in accordance with these test methods. Consideration of the w/d ratio is paramount when designing a test program in order to directly compare the performance of different fire protection materials applied to structural steel beams and columns. It is desirable to conduct tests on a common size member, such as a W10 by 49 (W250 by 73) column to accommodate ease of making relative comparisons of thermal performance.

12.3 For fire containment steel wall specimens, the thickness of the steel plate will influence fire endurance as determined by these test methods. When designing the test program, however, in order to directly compare the performance of different fire protection materials applied to steel wall specimens, tests shall be performed using a standard steel wall thickness of 0.18 ± 0.02 -in. (4.5 ± 0.5 -mm). The 0.18 ± 0.02 -in. thick specimen is specified by IMO Resolution A.517(13) and as such, has had a large number of tests conducted on it.

⁷ Marinite XL, a registered trademark of Johns-Manville Co., Manville Corp., Product Information Center, P.O. Box 5108, Denver, CO 80217, has been found suitable for this purpose. It has the following thermal properties: density of 46 lb/ft³ (737 kg/m³), thermal conductivity (at 350°F (177°C)) of 0.89 Btu.in./h-ft² · °F (0.13 W/m·°K), and specific heat (at 200°F (93°C)) of 0.28 Btu/lb. °F (117 J/kg·K).

13. Conditioning

13.1 Protect the test specimen during and after fabrication to ensure the quality of its condition at the time of test. The specimen shall not be tested until after its strength has at least attained its design strength.

13.2 If the test specimen contains moisture, solvents, plasticizers, curing compounds, or similar agents, condition the specimen prior to the test with the objective of providing a condition within the specimen which is representative of the intended end-use environment of the assembly. When accelerated drying techniques are used to achieve this objective, avoid drying procedures that will alter the structural or fire endurance characteristics of the test specimen from those produced as a result of air drying under ambient atmospheric conditions. Record the temperature and humidity of the test specimen at the time of the fire test. (See 13.4.)

13.3 For some assemblies, it is difficult or impossible to achieve the objective of 13.2 even after an excessively lengthy period of time. In the event that specimens, air dried in a heated building, fail to meet this objective after a 12-month conditioning period or in the event that the nature of the assembly is such that it is evident that drying of the specimen interior is prevented due to hermetic sealing, the requirements of 13.2 are waived. In such cases, test the specimen after its strength has at least attained its design strength. Record the temperature and humidity of the test specimen at the time of the fire test. (See 13.4.)

13.4 If the specimen contains moisture or solvents, measure the actual content of such agents within 72 h prior to the test. Obtain this information by weight determinations, moisture meters, or any other appropriate techniques deemed suitable by the testing laboratory. If the condition of the tested specimen is capable of significantly changing within 72 h preceding the test, the actual content of moisture, solvents, and similar agents shall be made within 24 h prior to the test.

14. Accelerated Weathering and Aging Tests

14.1 Test procedures are specified in 14.2-14.9 that represent a recommended minimum test program for evaluating the weatherability for fire protection materials and assemblies using accelerated weathering and aging tests. These tests are applicable for fire protection materials for structural steel. Determination of the applicability of these test methods to other materials and assemblies is left to those interested parties involved. Further, because it is recognized that accelerated aging/weathering testing is an art and not a science, requirements for preconditioning tests prior to aging/weather exposure (for example, tensile stressing of brittle materials), and additional exposure environments for some fire protection materials for structural steel or other materials and assemblies, are left to the parties involved that have a particular concern about a particular material or an assembly in a particular environmental exposure.

NOTE 3—By defining a specific test program for protection materials for structural steel, it is not to be construed that the fire protection properties of these materials are especially vulnerable to weathering effects. Rather, it is a reflection of the state of the art that such a test program exists for these materials.

14.2 For evaluation of a protective material, apply the material to 2-ft long, 6 by 6 in. steel tubes with a 3/16-in. wall thickness. Provide each end of each steel tube with steel caps covered with the protection material being investigated.

14.3 Locate four Type K thermocouples having a time constant not greater than 2 s on each steel tube. The thermocouples shall measure the temperature at the center of each face of the steel tube.

14.4 The protective material thickness shall be sufficient to provide an endurance time of approximately 70 ± 29 min in accordance with 16.2.5.

14.5 Prepare a minimum of seven samples. Expose at least six samples to the environments and use at least one sample as a control for comparison purposes. Expose a sample to only one environment before it is subjected to the fire endurance test.

14.6 The accelerated weathering or aging environments shall consist of:

14.6.1 *Accelerated Aging*—A circulating air oven maintained at $160 \pm 5^\circ\text{F}$ ($71 \pm 3^\circ\text{C}$) and the air circulated at a rate to change the air volume in the oven each 8 h. The exposure time shall be at least 6480 h (270 days).

14.6.2 *Accelerated Weathering Exposure*—A weatherometer in accordance with Practice D822. The exposure time shall be at least 720 h (30 days).

14.6.2.1 Samples are mounted on a rotating drum within the weatherometer. Operation of the weatherometer requires samples to be balanced and the sample weight not exceed the limits of the equipment.

14.6.3 *Wet/Freeze/Thaw Exposure*—Twelve cycles of simulated rainfall at 0.7 in. (17.8 mm) per day for 72 h, followed by an immediate exposure to $-40 \pm 5^\circ\text{F}$ ($-40 \pm 3^\circ\text{C}$) for 24 h, and then an immediate exposure to $+140 \pm 5^\circ\text{F}$ ($+60 \pm 3^\circ\text{C}$) for 72 h.

14.6.4 *High Humidity Exposure*—A chamber maintained at 100 % relative humidity ($+0, -3$ %) and $95 \pm 5^\circ\text{F}$ ($35 \pm 3^\circ\text{C}$). The exposure time shall be at least 4320 h (180 days).

14.6.5 *Heavy Industrial Atmospheric Exposure*—A chamber maintained at $95 \pm 5^\circ\text{F}$ ($35 \pm 3^\circ\text{C}$). There shall be a pan filled to a depth of 1 in. (25.4 mm) with water in the bottom of the test chamber. Maintain the gaseous mixture in the test chamber from 97 to 98 % air, 1 to 1.5 % sulphur dioxide, 1 to 1.5 % carbon dioxide (by volume). The exposure time shall be at least 720 h.

14.6.6 *Salt Spray or Salt Fog*—If this type of exposure is required, perform the test in accordance with Test Method B117.

14.7 Note any changes in the physical integrity, adhesion, or general appearance of fire protection materials or assemblies tested under the conditions of 14.6.

14.8 Subject seven samples to the fire exposure defined in Section 6. Determine the time to reach an average temperature of 1000°F (538°C) as measured by the thermocouples attached to a tube.

14.9 A fire protection material shall be judged to have not been affected by aging or weathering if the average endurance time to 1000°F for each sample exposed to the conditions of 14.6 is at least 75 % of the endurance time determined for the control sample.

TEST METHOD A—COLUMN TESTS

15. Procedure

15.1 *Loaded Specimens:*

15.1.1 Test the column assembly in a vertical orientation. The length of the assembly subjected to the fire exposure shall be not less than 9 ft (2.74 m). Apply the contemplated details of connections and their protection, if any, according to methods of field practice. Subject the assembly to the specified fire exposure simultaneously on all sides.

15.1.2 Throughout the fire endurance test, apply a superimposed load to the column to simulate the maximum load condition allowed under nationally recognized structural design criteria unless limited design criteria are specified with a corresponding reduced load. Calculate the applied load so as to be consistent with the degree of the end fixity inherent in the laboratory's system for transmitting the load to the column assembly. Make provisions for transmitting the load to the exposed portion of the column without increasing the effective column length.

15.1.3 The column assembly shall sustain the superimposed applied load during the fire endurance test for a period equal to that for which classification is desired.

15.2 *Unloaded Steel Specimens:*

15.2.1 The following test procedure does not require application of a superimposed load at any time. This procedure is used to evaluate the fire endurance of steel columns where the applied fire protection materials are not intended to carry any of the superimposed load acting on the column.

15.2.2 Use of this procedure for the testing of other than steel columns is allowed provided that appropriate endpoint or acceptance criteria have been established and substantiated. Base such acceptance criteria upon the temperature of the column assembly and other parameters that influence the load carrying capacity of the column (such as depth of char for timber columns). Unless otherwise specified, base the acceptance criteria upon an axially loaded specimen using the allowable design load for the specific column assembly as the applied load.

15.2.3 Test the column assembly in a vertical orientation. The length of the test specimen subjected to the fire exposure shall be not less than 8 ft (2.44 m). Apply the contemplated details of connections and their protection, if any, according to methods of field practice. Subject the column to the specified fire exposure simultaneously on all sides.

15.2.4 Restrain the applied protection against longitudinal temperature expansion greater than that of the steel column with rigid steel plates or reinforced concrete attached to the ends of the steel column before the protection is applied. The size of the plates or amount of concrete shall provide direct bearing for the entire transverse area of the protection. Provide the ends of the specimen, including the means for restraint of the applied protection, with thermal insulation to limit direct heat transfer from the furnace.

15.2.5 Measure the temperature of the column assembly at four levels throughout the fire endurance test. The upper and lower levels shall be located 2 ft (0.61 m) from the ends of the column and the intermediate levels shall be equally spaced. Position at least three thermocouples at each level so as to measure the temperature of significant elements of the steel column. Use metal or ceramic sheathed thermocouples if the nature of the protection material is such that other types of thermocouples will not function properly (for example, short-out in a charring type protection material or one that releases significant amounts of water).

15.2.6 The average temperature at each of the four levels shall not exceed 1000°F (538°C), and the maximum temperature recorded by any individual thermocouple shall not exceed 1200°F (649°C), for a period equal to that for which classification is desired.

TEST METHOD B—BEAM TESTS

16. Procedure

16.1 *Loaded Specimens:*

16.1.1 Test the beam assembly in a horizontal orientation. The length of the assembly subjected to the fire exposure shall be not less than 12 ft (3.7 m). Subject the assemblies to the specified fire exposure simultaneously on all sides (Note 54). The ends of the beam shall be simply supported and the beam shall not be restrained against longitudinal thermal expansion.

NOTE 4—Because this test method is aimed at fires generally occurring at HPI and similar facilities where flooring is not a great concern on structural beams, the fire test method for beam assemblies specifies that the beam be totally engulfed. This varies from Test Methods E119, in which the beam is an integral part of a ceiling assembly, and therefore is subjected to fire from only three sides.

16.1.2 Throughout the fire endurance test, apply a superimposed load to the beam to simulate maximum load condition. This load shall be the maximum load condition allowed under nationally recognized structural design criteria unless limited design criteria are specified and a corresponding reduced load applied.

16.1.3 The beam shall sustain the superimposed load during the fire endurance test for a period equal to that for which classification is desired.

16.2 *Unloaded Steel Specimens:*

16.2.1 The following test procedure does not require the application of a superimposed load at any time. This procedure is used to evaluate the fire endurance of steel beams where the applied protection materials are not intended to carry any of the superimposed load acting on the beam.

NOTE 5—This procedure is used for the testing of other than steel beams provided that appropriate endpoint or acceptance criteria have been established and substantiated. Such acceptance criteria shall be based upon the temperature of the beam assembly and other parameters that are capable of influencing the load carrying capacity of the beam (such as depth of char for timber beams).

16.2.2 Test the beam assembly in a horizontal orientation. The length of the test specimen subjected to the fire exposure shall be not less than 12 ft (3.67 m). Subject the beams to the specified fire exposure simultaneously on all sides (Note 54).

16.2.3 Restrain the applied protection against longitudinal temperature expansion greater than that of the steel beam or girder with rigid steel plates or reinforced concrete attached to the ends of the steel member before the protection is applied. The size of the plates or amount of concrete shall be adequate to provide direct bearing for the entire transverse area of the protection. Provide the ends of the member, including the means for restraint of the applied protection, with thermal insulation to limit direct heat transfer from the furnace.

16.2.4 Measure the temperature of the steel in the beam or girder with not less than four thermocouples at each of four sections equally spaced along the length of the beam and symmetrically disposed and not nearer than 2 ft (0.6 m) from the inside face of the test facility. Symmetrically place the thermocouples at each section so as to measure significant temperatures of the component elements of the steel section. Use metal- or ceramic-sheathed thermocouples if the nature of the protection material is such that other types of thermocouples will not function properly.

16.2.5 The average temperature at each of the four levels shall not exceed 1000°F (538°C), and the maximum temperature recorded by any individual thermocouple shall not exceed 1200°F (649°C), for a period equal to that for which classification is desired.

16.2.6 See 5.3.2.

16.2.7 *Piping*—Use of these procedures for the testing of items other than steel beams, such as piping is allowed. However, failure criteria are not provided in these test methods for these types of assemblies. As a result, these types of tests should not be conducted unless appropriate endpoint or acceptance criteria have been established and substantiated. Base such acceptance criteria upon the temperature of the assembly and any other parameters that may influence its performance.

TEST METHOD C—TESTS OF FIRE-CONTAINMENT CAPABILITY OF WALLS

17. Tests of Fire-Containment Capability of Walls

17.1 The purpose of this test method is to evaluate the fire-containment capability of members having structural, fire containment, or other functions, or combinations thereof, such as walls, partitions, or bulkheads in buildings, and marine structures and offshore petroleum chemical platforms. For brevity, the term *wall* is used in provisions that also apply to other barrier, or containment element configurations such as *partitions* or *bulkheads*.

17.2 *Size of Specimen*—The test specimen shall have a fire-exposed surface of not less than 50 ft² (4.65 m²) and a height of not less than 8 ft (2.44 m). Restrain the test specimen on all four edges. See 12.3.

17.2.1 Adjust the specimen size when required to correspond with the size specified in a particular regulation. For example, 46 CFR 164.007, which concerns the performance of materials intended for use as structural insulation on merchant vessels, requires the samples to be 40 by 60 in. (1.02 by 1.52 m).

17.3 *Steel Wall*—The specimen shall have a structural core of flat steel plate, suitably stiffened, representative of the intended actual construction. In the absence of a specific construction design, the specimen shall have a structural core of stiffened flat steel plate designed and fabricated in accordance with the specifications shown in Fig. 4. When the actual construction will contain one or more joints, the specimen shall be tested with at least one joint.

NOTE 6—This procedure is used for the fire-containment listing of other than steel walls provided that an appropriate wall design has been defined and appropriate endpoint or acceptance criteria have been established and substantiated. Such acceptance criteria shall be based upon the temperature of the nonfire exposed face of the wall and other parameters that influence the intended fire-containment performance of the wall.

17.4 The surface of the wall assembly designated the exposed side shall be subjected to the specified fire exposure of 6.2 through 6.3.

17.5 *Temperature Measurements During Testing:*

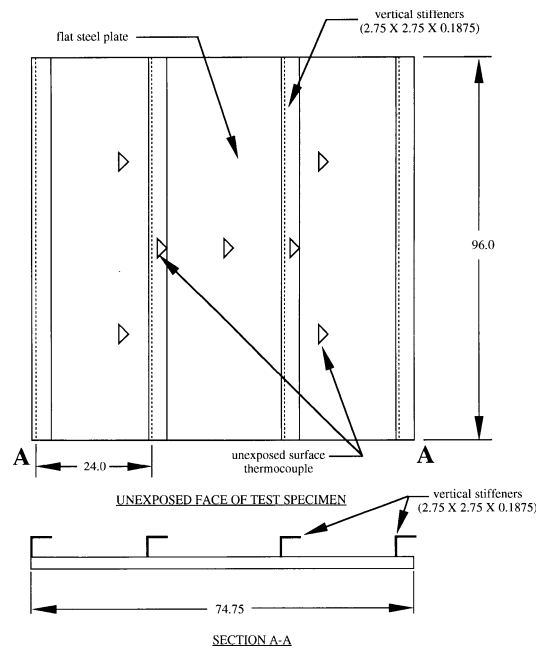

NOTE 1—The overall dimensions shown are minimum. Increase as necessary to fit supporting frame into the wall of test furnace.

NOTE 2—Except for steel plate thickness and thermocouple instrumentation, this specimen is intended to be identical to the steel bulkhead specified in IMO Resolution A.517(13). If IMO acceptance is desired, a second set of thermocouples may be required.

FIG. 4 Design of Steel Fire-Containment Wall Test Specimen

17.5.1 Measure the surface temperatures on the unexposed side of the test specimen throughout the fire test by thermocouples located as follows and indicated in Fig. 4:

17.5.1.1 Four thermocouples, each located approximately in the center of a quarter section of the test specimen.

17.5.1.2 One thermocouple located close to the center of the test specimen, but away from the joint, if any.

17.5.1.3 One thermocouple is placed within the partially enclosed area of each of the two central stiffeners, if such stiffeners are present. For a specific construction design, where the stiffeners form an enclosed channel, locate these thermocouples on areas of the unexposed wall surface adjacent to the two central stiffeners.

17.5.1.4 At least one thermocouple at a joint, if any is included in the specimen being tested.

17.5.2 Place the thermocouples used for temperature measurement on the unexposed surface in accordance with Test Methods E119. Also, see Fig. 4.

17.6 Conditions of Acceptance—The test method shall be regarded as successful if the following conditions are met:

17.6.1 The fire-containment wall assembly shall have withstood the fire endurance test without passage of flame or gases hot enough to ignite cotton waste, for a time period equal to that for which classification is desired.

17.6.2 Transmission of heat through the wall or partition during the fire endurance test period shall not have raised the average temperature on its unexposed surface more than 250°F (139°C) above its initial temperature, nor the temperature of any one point on the surface, including any joint, more than 325°F (181°C) above its initial temperature. The average temperature of the unexposed surface shall be the average of the readings of the thermocouples specified in 17.5.1 and 17.5.2.

18. Report

18.1 Report the following information:

18.1.1 General description of the test facility including the method of developing the specified fire environment and the results and date of the current calibration of the test facility. Report the type, location, and orientation of all instrumentation (such as heat flux meters and thermocouple assemblies) used to monitor or control, or both, the fire exposure.

18.1.2 For a calibration test, report the heat flux incident on the test specimen and the temperature of the fire environment with measurements at intervals of no more than 3 min. For an actual test, report the temperature of the fire environment with measurements at intervals of no more than 3 min.

18.1.3 Indicate whether the fire environment resulted in an exposure that satisfied the criteria set forth herein, in particular the agreement between the time-temperature curves from the calibration test and the actual test.

18.1.4 Indicate the test procedure that was followed and the resulting fire endurance period to the nearest minute. For loaded test specimens, include a description of the laboratory equipment for applying, measuring, and maintaining the load. Also include a discussion of the test method used to determine the applied load.