



Designation: ~~D1238~~—~~10~~ **D1238** – 13

Standard Test Method for Melt Flow Rates of Thermoplastics by Extrusion Plastometer¹

This standard is issued under the fixed designation D1238; the number immediately following the designation indicates the year of original adoption or, in the case of revision, the year of last revision. A number in parentheses indicates the year of last reapproval. A superscript epsilon (ϵ) indicates an editorial change since the last revision or reapproval.

1. Scope*

1.1 This test method covers the determination of the rate of extrusion of molten thermoplastic resins using an extrusion plastometer. After a specified preheating time, resin is extruded through a die with a specified length and orifice diameter under prescribed conditions of temperature, load, and piston position in the barrel. Four procedures are described. Comparable results have been obtained by these procedures in interlaboratory round-robin measurements of several materials and are described in Section 15.

1.2 Procedure A is used to determine the melt flow rate (MFR) of a thermoplastic material. The units of measure are grams of material/10 minutes (g/10 min). It is based on the measurement of the mass of material that extrudes from the die over a given period of time. It is generally used for materials having melt flow rates that fall between 0.15 and 50 g/10 min (see Note 1).

1.3 Procedure B is an automatically timed measurement used to determine the melt flow rate (MFR) as well as the melt volume rate (MVR) of thermoplastic materials. MFR measurements made with Procedure B are reported in g/10 minutes. MVR measurements are reported in cubic centimetres/ten minutes (cm³/10 min). Procedure B measurements are based on the determination of the volume of material extruded from the die over a given period of time. The volume is converted to a mass measurement by multiplying the result by the melt density value for the material (see Note 2). Procedure B is generally used with materials having melt flow rates from 0.50 to 1500 g/10 min.

1.4 Procedure C is an automatically timed measurement used to determine the melt flow rate (MFR) of polyolefin materials. It is generally used as an alternative to Procedure B on samples having melt flow rates greater than 75 g/10 min. Procedure C involves the use of a modified die, commonly referred to as a “half-die,” which has half the height and half the internal diameter of the standard die specified for use in Procedures A and B thus maintaining the same length to diameter ratio. The test procedure is similar to Procedure B, but the results obtained with Procedure C shall not be assumed to be half of those results produced with Procedure B.

1.5 Procedure D is a multi-weight test commonly referred to as a “Flow Rate Ratio” (FRR) test. Procedure D is designed to allow MFR determinations to be made using two or three different test loads (either increasing or decreasing the load during the test) on one charge of material. The FRR is a dimensionless number derived by dividing the MFR at the higher test load by the MFR at the lower test load. Results generated from multi-weight tests shall not be directly compared with results derived from Procedure A or Procedure B.

NOTE 1—Polymers having melt flow rates less than 0.15 or greater than 900 g/10 min may be tested by the procedures in this test method; however, precision data have not been developed.

NOTE 2—Melt density is the density of the material in its molten state. It is not to be confused with the standard density value of the material. See Table 3.

NOTE 3—This test method and ISO 1133 address the same subject matter, but differ in technical content.

1.6 *This standard does not purport to address the safety concerns, if any, associated with its use. It is the responsibility of the user of this standard to establish appropriate safety and health practices and determine the applicability of regulatory limitations prior to use.*

¹ This test method is under the jurisdiction of ASTM Committee D20 on Plastics and is the direct responsibility of Subcommittee D20.30 on Thermal Properties (Section D20.30.08).

Current edition approved Feb. 1, 2010/Aug. 1, 2013. Published March 2010/August 2013. Originally approved in 1965. Last previous edition approved in 2004/2010 as ~~D1238 - 04e~~ D1238 - 10. DOI: ~~10.1520/D1238-10~~ 10.1520/D1238-13.

*A Summary of Changes section appears at the end of this standard

2. Referenced Documents

2.1 *ASTM Standards:*²

D618 Practice for Conditioning Plastics for Testing

D883 Terminology Relating to Plastics

D3364 Test Method for Flow Rates for Poly(Vinyl Chloride) with Molecular Structural Implications

D4000 Classification System for Specifying Plastic Materials

E691 Practice for Conducting an Interlaboratory Study to Determine the Precision of a Test Method

iTeh Standards (<https://standards.itih.ai>) Document Preview

[ASTM D1238-13](#)

<https://standards.itih.ai/catalog/standards/sist/7b7762a5-bd64-45d0-86f9-82aaf31319e/astm-d1238-13>

² For referenced ASTM standards, visit the ASTM website, www.astm.org, or contact ASTM Customer Service at service@astm.org. For *Annual Book of ASTM Standards* volume information, refer to the standard's Document Summary page on the ASTM website.

2.2 *ANSI Standard:*

B46.1 on Surface Texture³

2.3 *ISO Standard:*

ISO 1133 Determination of the Melt-Mass Flow Rate (MFR) and the Melt Volume-Flow Rate (MVR) of Thermoplastics³

3. Terminology

3.1 *General:*

3.1.1 Definitions are in accordance with Terminology **D883** unless otherwise specified.

4. Significance and Use

4.1 This test method is particularly useful for quality control tests on thermoplastics.

4.2 The data produced by this test method serves to indicate the uniformity of the flow rate of the polymer as made by an individual process. It is not to be used as an indication of uniformity of other properties without valid correlation with data from other tests.

4.3 The flow rate obtained with the extrusion plastometer is not a fundamental polymer property. It is an empirically defined parameter critically influenced by the physical properties and molecular structure of the polymer and the conditions of measurement. The rheological characteristics of polymer melts depend on a number of variables. It is possible that the values of these variables occurring in this test will differ substantially from those in large-scale processes, which would result in data that does not correlate directly with processing behavior.

4.4 Measure the flow rate of a material using any of the conditions listed for the material in **8.2X4.1**. For many materials, there are specifications that require the use of this test method, but with some procedural modifications that take precedence when adhering to the specification. Therefore, it is advisable to refer to that material specification before using this test method. Table 1 in Classification **D4000** lists the ASTM materials standards that currently exist. An alternative test method for poly (vinyl chloride) (PVC) compounds is found in **Test Method D3364**.

4.5 Additional characterization of a material can be obtained if more than one condition is used. In the case that two or more conditions are employed, a Flow Rate Ratio (FRR) is obtained by dividing the flow rate at one condition by the flow rate at another condition. Procedure D provides one method to measure more than one condition in a single charge.

4.6 Frequently, variations in test technique, apparatus geometry, or test conditions, which defy all but the most careful scrutiny, exist, causing discrepancies in flow rate determinations. A troubleshooting guide is found in **Appendix X2** and it is a resource to be used to identify sources of test error.

5. Apparatus

5.1 *Extrusion Plastometer (Alternative Names—Melt Indexer, Melt Flow Indexer):*

NOTE 4—Older plastometers that were manufactured in accordance with “design specifications” detailed in previous revisions of this test method (pre D1238 - 04c) are deemed to be acceptable, as long as they meet the dimensional and performance specifications stated in this section.

NOTE 5—Relatively minor changes in the design and arrangement of the component parts have been shown to cause differences in results among laboratories. For the best interlaboratory agreement, it is important that the design adhere closely to the description herein; otherwise, it should be determined that modifications do not influence the results. Refer to **Fig. 1**.

5.1.1 The apparatus shall be a dead-weight piston plastometer consisting of a thermostatically controlled heated steel cylinder with a bore that contains a die at the lower end, and a weighted piston operating within the cylinder. The essential features of the plastometer, illustrated in **Figs. 1 and 2**, are described in **5.2-5.12**. The bore of the extrusion plastometer shall be properly aligned in the vertical direction (see **Appendix X1**). All dimensional measurements shall be made when the article being measured is at $23 \pm 5^\circ\text{C}$.

5.2 *Cylinder*—The cylinder shall be $50 \text{ mm} \pm 10 \text{ mm}$ in diameter, 115 to 180 mm in length with a smooth, straight bore $9.5504 \pm 0.0076 \text{ mm}$ in diameter. The cylinder bore shall be manufactured in a way that produces a finish approximately 12 rms or better in accordance with ANSI B46.1. Means shall be provided to monitor the temperature inside the bore.

5.3 *Die (Orifice):*

5.3.1 *Standard Die*—The outside diameter of the die shall be such that it will fall freely to the bottom of the hole in the cylinder. The orifice of the die shall have a smooth straight bore $2.095 \pm 0.005 \text{ mm}$ in diameter and shall be $8.000 \pm 0.025 \text{ mm}$ in length (see **Fig. 2**). The bore of the orifice and its finish are critical. It shall have no visible drill or other tool marks and no detectable eccentricity. The bore of the orifice shall be manufactured by techniques known to produce finishes approximately 12 rms or better in accordance with ANSI B46.1.

³ Available from American National Standards Institute (ANSI), 25 W. 43rd St., 4th Floor, New York, NY 10036, <http://www.ansi.org>.

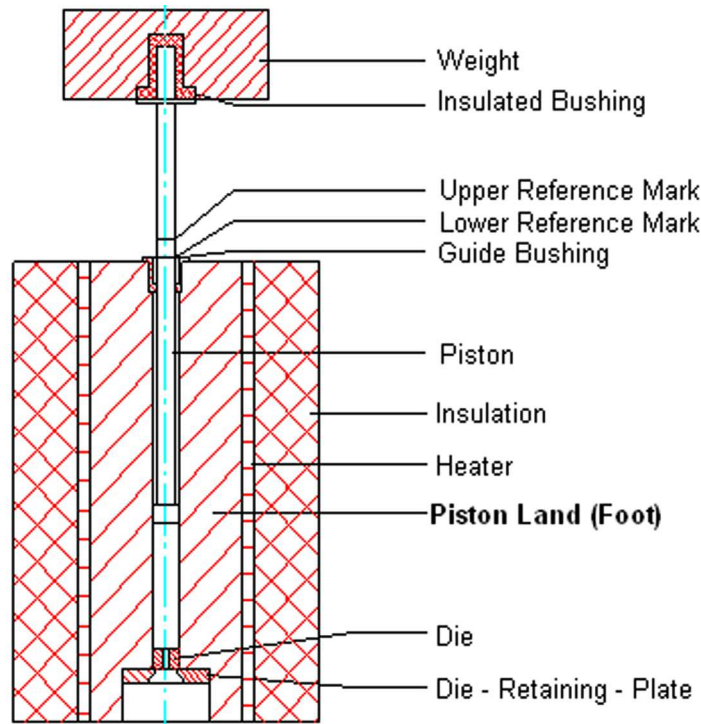

FIG. 1 General Arrangement of Extrusion Plastometer (See Section 5.)

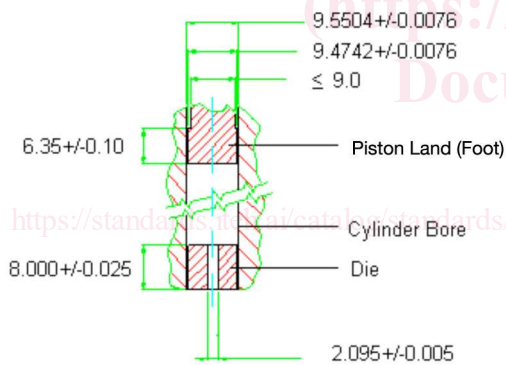

Figure # 2 - Dimensions of the cylinder bore, piston foot & standard die
All measurements in "mm"

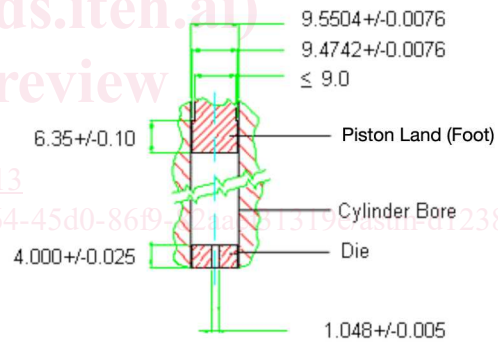

Figure # 2 a - Dimensions of the cylinder bore, piston foot & "half" die

FIG. 2 Details of Extrusion Plastometer

5.3.2 "Half" Die—Used for Procedure C. When testing polyolefins with a MFR of 75 or greater (using the standard die), an alternate die has shown to improve the reproducibility of results by reducing the flow rate of these materials. The outside diameter of the die shall be such that it will fall freely to the bottom of the hole in the cylinder. The orifice shall have a smooth straight bore 1.048 ± 0.005 mm in diameter and shall be 4.000 ± 0.025 mm in length (see Fig. 2A). The bore of the orifice and its finish are critical. It shall have no visible drill or other tool marks and no detectable eccentricity. The bore of the orifice shall be manufactured by techniques known to produce finishes approximately 12 rms or better in accordance with ANSI B46.1 (Note Note 6). No spacer shall be used with this die.

NOTE 6—Recommended die material is tungsten carbide. Also satisfactory are steel, synthetic sapphire, and cobalt-chromium-tungsten alloy. When softer materials are used, it will be necessary to conduct critical dimensional checks and visual inspections on the die more often.

5.4 Piston:

5.4.1 The piston shall be made of steel. There shall be insulation at the top as a barrier to heat transfer from the piston to the weight. The piston shall be prevented from rubbing on the bore. Most commercially available instruments use a loose fitting metal guide sleeve, but other methods are acceptable. The weight of the sleeve shall not be considered as part of the test load. The land (foot) of the piston shall be 9.4742 ± 0.0076 mm in diameter and 6.35 ± 0.10 mm in length. Above the land, the piston shall be

relieved to ≤ 9.0 mm in diameter (see Fig. 2). The piston land shall be manufactured by techniques known to produce finishes approximately 12 rms in accordance with ANSI B46.1. If corrosion is a problem, the piston or piston land, if removable, shall be made of corrosion resistant material.

5.4.2 For procedure A, the piston shall be scribed with two reference marks 4 mm apart in such fashion that when the lower mark coincides with the top of the cylinder, guide sleeve or other suitable reference point, the bottom of the piston is 48 mm above the top of the die (see Fig. 1) and the timed test run shall start within these two reference marks. The targeted starting point shall be 46 ± 2 mm above the upper face of the die. (see Fig. 1).

5.4.3 The combined weight of piston and load shall be within a tolerance of ± 0.5 % of the selected load.

5.5 Temperature Control System:

5.5.1 The equipment shall have the capability of heating and maintaining the temperature inside the bore of the cylinder in accordance with the requirements specified in Table 1 throughout the duration of the test.

5.5.2 The preferred method for calibrating the temperature is to use a temperature sensor assembly having a sensor with at least an accuracy of $\pm 0.08^\circ\text{C}$ at 200°C and a 20 ± 0.5 -mm long brass tip press fit on the end of the sensor. The diameter of the brass tip shall closely match the diameter of the die and the length of the active measuring length of the temperature sensor (see Appendix X3).

5.5.3 Temperatures shall be verified with the bottom of the temperature sensor at 10 and 75 ± 1 mm above the upper face of the die and at each test temperature, without touching the die. Allow at least four minutes for equilibrium of temperature to be reached for each position. Temperature variation shall be determined over a minimum of 15 minutes. When using the “half” die, the temperature indicating device shall be calibrated as stated in Table 1 except temperatures are measured at 79 ± 1 mm and 14 ± 1 mm above the upper surface of the die.

5.5.4 An alternative method is to insert the temperature sensor without a brass tip into the melt from the top of the cylinder so that it is 10 and 75 ± 1 mm above the upper face of the die.

5.5.5 The temperature sensor and readout equipment used for calibration of the extrusion plastometer shall be traceable to a national standard (for example, NIST).

5.6 Timing Device/System—For Procedure A, a timing device with an accuracy of 0.1 s shall be used. For Procedures B, C, and D, an automatic timing system shall measure and time piston movement within the specified travel range. The requirements of the automatic timing system shall be as follows:

5.6.1 Sense and indicate the piston travel time within ± 0.01 s.

5.6.2 Measure piston travel within ± 0.4 % of the nominal selected value (see 10.7) for use in the flow rate calculations.

5.6.3 Operate within a fixed portion of the cylinder. This is defined as the portion of the cylinder between 48 mm and 18.35 mm above the top of the die.

5.6.4 Any effects on the applied load caused by the Timing Device/System must be included in the allowable tolerance given in 5.4.3.

5.6.5 The equipment used to calibrate the Timing Device/System shall be traceable to a national standard (for example, NIST).

5.7 Operating Tools:

5.7.1 Level—Used to verify the vertical alignment of the bore of the extrusion plastometer. This is necessary to minimize subtractive loads resulting from rubbing or friction between the piston tip and sidewall. Means of alignment are discussed in Appendix X1.

5.7.2 Calibrated Go/No-Go Gauge:

5.7.2.1 For the standard die, a go/no-go gauge suitable to inspect the inner diameter of the hole in the die. The go member of the gauge shall be no smaller than 2.090 mm. The no-go member shall be no larger than 2.100 mm.

5.7.2.2 For the “half” die, a go/no-go gauge suitable to inspect the hole in the die. The go member of the gauge shall be no smaller than 1.043 mm. The no-go member shall be no larger than 1.053 mm.

5.7.3 Funnel—For charging samples to the cylinder

5.7.4 Packing Tool—For charging samples to the cylinder

TABLE 1 Maximum Allowable Variation in Temperature with Distance and Time Throughout the Test

Test temperature set point T °C	Temperature tolerance, °C	
	At 75 ± 1 mm above the die surface (°C) ^A	At 10 ± 1 mm above the die surface (°C) ^A
$125 \leq T < 250$	± 2.0	± 0.2
$250 \leq T < 300$	± 2.5	± 0.5
$300 \leq T$	± 3.0	± 1.0

^AWhen using the “half” die, the temperature indicating device shall be calibrated as stated in this table except temperatures are measured at nominal 79 ± 1 mm and $14 \text{ mm} \pm 1 \text{ mm}$ above the upper surface of the die.

5.7.5 *Spatula*—Or similar device used to cut extrudate

5.7.6 *Balance*—Capable of weighing to 0.001 g

5.8 *Cleaning Equipment:*

5.8.1 *Cylinder bore cleaning tool*

5.8.2 *Die cleaning tool*

5.8.3 *Cotton patches*

5.9 *Weight Support*—Used with high Melt Flow Rate material to prevent material from flowing out during the preheat period.

5.10 *Die Plug*—Used with high melt flow rate material to plug the die when weight support measures are not enough to prevent material from flowing out during the preheat period.

5.11 *Automatic Weight Lowering and Lifting Device*—Optional for Procedures A, B, and C, but required for Procedure D. Device for automatically applying test loads to the piston. This device is often useful as a weight support.

5.12 *Multi-Weight (Flow Rate Ratio) Accessory*—For testing in accordance with Procedure D, it is necessary to have an accessory that permits Melt Flow Rate determinations to be made using two or three different test loads on one charge of material by loading or unloading test loads, or both, at pre-set heights.

NOTE 7—Different manufacturers of equipment may offer options that help to automate the test and/or data collection. These are acceptable for use provided they operate in a manner that does not conflict with descriptions in Section 5 and the procedures listed in Sections 9, 10, 11, and 12.

6. Test Specimen

6.1 The test specimen is permitted to be in any form that allows it to be introduced into the bore of the cylinder, for example, powder, granules, strips of film, or molded slugs.

NOTE 8—It may be desirable to pre-form or pelletize a powder. Trapped air causes the piston to fall faster, hence measurements are affected.

7. Conditioning

7.1 Many thermoplastic materials do not require conditioning prior to testing. Materials which contain volatile components, are chemically reactive, or have other special characteristics most probably require appropriate conditioning procedures. Moisture not only affects reproducibility of flow rate measurement but, in some types of materials, degradation is accelerated by moisture at the high temperatures used in testing. Check the applicable material specification for any conditioning requirements before using this test. See Practice D618 for appropriate conditioning practices.

8. Procedural Conditions

8.1 ~~Standard conditions of test are given~~ A list of possible test conditions for various materials is shown in [Table X4.1](#) found in [Appendix X4](#). Test conditions shall be shown as: Condition / , where the temperature in degrees Celsius is shown first, followed by the weight in kilograms. For example: Condition 190/2.16.

NOTE 9—Some materials may require special materials of construction or handling for performing this test. Please refer to the material specification for appropriate recommendations.

8.2 ~~Table 2 shows conditions that have been found satisfactory for the material listed.~~

NOTE 9—Some materials may require special materials of construction or handling for performing this test. Please refer to the material specification for appropriate recommendations.

9. Procedure A—Manual Operation

9.1 Select conditions of temperature and load from [8.2X4.1](#) or in accordance with material specifications. Where multiple test conditions exist, test conditions shall be agreed upon by the cooperating laboratories. If test conditions are not known, select conditions that result in flow rates between 0.15 to 50 g/10 min.

9.2 Inspect the extrusion plastometer for cleanliness (see [Note 10](#)). All surfaces of the cylinder bore, die and piston shall be free of any residue from previous tests.

NOTE 10—The degree of cleanliness can significantly influence the flow rate results, therefore a thorough method of cleaning should be established. It has been found that swabbing the barrel with a clean cotton patch several times is satisfactory for most materials and that the die, barrel, and piston are more easily cleaned while hot. For materials that are difficult to clean from the metal surfaces, use of a brass brush has been found to be satisfactory.

9.3 Check the die bore diameter at frequent intervals with appropriately sized go/no-go gauges (checked with die at $23 \pm 5^\circ\text{C}$) to verify that the die is within the tolerances given in [5.3.1](#). Visually examine the die bore to verify that it is not scratched or damaged. Also visually inspect the land of the piston foot to verify that it is not scratched or damaged and use a calibrated micrometer to verify that the dimensions are within the tolerances given in [5.4.1](#) (see [Note 11](#)).

NOTE 11—Cleaning and usage will eventually cause damage or wear to the, bore, die and the land of the piston. Data has shown that erroneous results will be obtained if these components are not within the appropriate tolerances.

9.4 Set the temperature in accordance with the manufacturer's instructions.

9.5 Insert the die and the piston into the bore. Allow the temperature of the cylinder, with the piston and die in place, to stabilize within $\pm 0.2^{\circ}\text{C}$ of the selected test temperature for at least 15 min before starting a test. When equipment is used continuously, it is not necessary to heat the piston and die for 15 minutes when runs of the same or similar material at the same test temperature are being measured over a continuous time frame, provided the piston and die are cleaned and re-inserted into the bore within five minutes after removal from the extrusion plastometer at the end of each test. If the piston, or die, or both, are removed from the bore for longer than five minutes, they shall be considered “cold” and the full 15 minutes heating stabilization time shall be required.

9.6 Remove the piston from the bore (see **Note 12**). Within 60 seconds, charge the cylinder with a weighed portion of the sample in accordance with the expected flow rate (as given in **Table 32**), reinsert the piston and add the appropriate weight. The charging weights given in **Table 32** are merely suggestions, and the actual charging weight for a specific sample, if not known, will need to be determined by trial and error. Adjust the charge weight so that the piston is in the proper position at the end of the pre-heat period. If necessary, it is acceptable to purge excess material from the cylinder bore so that the piston is in the proper position at the end of the pre-heat period. Purging of material done at conditions with greater force than testing conditions shall be completed at least 2 min prior to making the initial cut-off (see **Note 13**).

NOTE 12—Placing the piston on an insulated surface after removing it from the bore will reduce heat loss.

NOTE 13—Material is purged by forcing the piston to a position that will ensure that subsequent travel of the piston during the remainder of the pre-heat period will position the piston at the correct start position. The material should be allowed to soften and melt before manually purging.

NOTE 14—Additional care may be necessary to prevent thermal degradation in the extrusion plastometer. This is sometimes done by the addition of an appropriate antioxidant. For highly unstable materials, it may be necessary to use alternative techniques as an indication of flow characteristics.

9.7 Start the test by initiating the timing device that monitors the pre-heat period, which is a period of time that allows the material to soften and begin to melt. The pre-heat period shall last for 7.0 ± 0.5 min from the completion of the charge unless otherwise stated in the materials specification.

9.8 For materials with flow rates greater than 10 g/10 min, a weight (and if needed, a piston) support must be used to prevent the piston from travelling during the pre-heat period in order to ensure that there is enough material in the bore to correctly test the material. The support is to be installed in a manner that holds the lower scribe mark of the piston approximately 25 mm above the top of the guide bushing or other suitable reference mark. Alternatively, it is acceptable for the operator to delay applying the weight to the piston. The support shall be removed or the weight applied to the piston at such a time as to allow the operator to make the initial cut-off within 7 ± 0.5 min of the completion of the charge.

NOTE 15—It has been found that the effect of supporting the weight is significant to the flow rate results. The choice of piston support was made to cover all conditions and flow rates 10 to 50 g/10 min. Piston/weight supports will vary between extrusion plastometer manufacturers.

9.9 At the end of the pre-heat period and when the top scribe mark on the piston is visible above the cylinder (or top of the guide sleeve) and the lower scribe mark is in the cylinder (or below the top of the guide sleeve) indicating that the piston land is 46 ± 2 mm from the top of the die, reset the timer to zero then simultaneously make the initial cut-off. Discard the extrudate from the

<https://standards.iteh.ai/catalog/standards/sist/7b7762a5-bd64-45d0-86f9-82aaef31319e/astm-d1238-13>

TABLE 32 Standard Test Conditions, Sample Mass,^A and Testing Time^B

Flow Range, g/10 min	Suggested Mass of Sample in Cylinder, g	Time Interval, min	Factor for Obtaining Flow Rate in g/10 min
0.15 to 1.0	2.5 to 3.0	6.00	1.67
>1.0 to 3.5	3.0 to 5.0	3.00	3.33
>3.5 to 10	4.0 to 8.0	1.00	10.00
>10 to 25	4.0 to 8.0	0.50	20.00
>25	4.0 to 8.0	0.25	40.00

^A This is a suggested mass for materials with melt densities of about 0.7 g/cm³. Correspondingly, greater quantities are suggested for materials of greater melt densities. Density of the molten resin (without filler) may be obtained using the procedure described by Terry, B. W., and Yang, K., “A New Method for Determining Melt Density as a Function of Pressure and Temperature,” *SPE Journal*, SPEJA, Vol. 20, No. 6, June 1964, p. 540 or the procedure described by Zoller, Paul, “The Pressure-Volume-Temperature Properties of Polyolefins,” *Journal of Applied Polymer Science*, Vol 23, 1979, p. 1051. It may also be obtained from the weight of an extruded known volume of resin at the desired temperature. For example, 25.4 mm (1 in.) of piston movement extrudes 1.804 cm³ of resin. An estimate of the density of the material can be calculated from the following equation:

$$\text{resin density at test temperature} = M/1.804$$

where:

M = mass of extruded resin.

^B See 9.13.

pre-heat period. Make the final cut-off exactly when the time interval selected (see [Table 32](#)) is reached. Collect and weigh the extrudate specimen. If the extrudate specimen contains visible bubbles, discard it and begin the test again. If the initial cut-off was initiated outside of the tolerances of the pre-heat period or the piston position requirements, discard the specimen and repeat the test with readjusted piston position after the initial purge, or change the weight.

9.10 Once the extrudate is cool, weigh to the nearest 1 mg.

9.11 Multiply the weight of the extrudate by the appropriate factor shown in [Table 32](#) to obtain the flow rate in grams per 10 min.

NOTE 16—Some labs have found it helpful to take interim cuts of the extrudate at uniform time intervals during the specified extrusion time period. The individual cuts may give an indication of the presence of bubbles which may be masked due to their size or to opacity of the sample which will result in test error. This technique is particularly helpful in the case of highly pigmented materials.

9.12 Purge the remainder of the sample from the bore and follow the extrusion plastometer manufacturer’s instructions for removing the die from the bore. Swab out the cylinder with cotton patches and the cylinder bore cleaning tool. Thoroughly clean the die and the piston to remove all residues ([Note 17](#)).

NOTE 17—The die may be cleaned by dissolving the residue in a solvent. A better method is pyrolytic decomposition of the residue in a nitrogen atmosphere. Place the die in a tubular combustion furnace or other device for heating to $550 \pm 10^\circ\text{C}$ and clean with a small nitrogen purge through the die. This method is preferable to flame or solvent cleaning, being faster than solvent cleaning and less detrimental to the die than an open flame. In certain cases where materials of a given class having similar flow characteristics are being tested consecutively, interim die cleaning may be unnecessary. In such cases, however, the effect of cleaning upon flow rate determination must be shown to be negligible if this step is avoided.

9.13 In case a specimen has a flow rate at the borderline of the ranges in [Table 32](#) and slightly different values are obtained at different time intervals, the referee value shall be obtained at the longer time interval.

10. Procedure B—Automatically Timed Flow Rate Measurement

10.1 Install/enable the automatic timing device on the extrusion plastometer.

10.2 Select conditions of temperature and load from [Table 2X4.1](#) or in accordance with material specifications. Where multiple test conditions exist, test conditions shall be agreed upon by the cooperating laboratories. A melt density value (see [Table 32](#) and [Table 43](#)) for the material is required if MFR is to be calculated from the results.

10.3 Inspect the extrusion plastometer for cleanliness (see [Note 17](#)). All surfaces of the cylinder bore, die and piston shall be free of any residue from previous tests.

10.4 Check the die bore diameter at frequent intervals with appropriately sized go/no-go gauges (checked with die at $23 \pm 5^\circ\text{C}$) to verify that the die is within the tolerances given in [5.3](#). Visually examine the die bore to verify that it is not scratched or damaged. Also visually inspect the land of the piston foot to verify that it is not scratched or damaged and use a calibrated micrometer to verify that the dimensions are within the tolerances given in [5.4.1](#) (see [Note 11](#)).

10.5 Set the temperature in accordance with the manufacturer’s instructions.

10.6 Insert the die and the piston into the bore. Allow the temperature of the cylinder with the piston and die in place to stabilize within $\pm 0.2^\circ\text{C}$ of the selected test temperature for at least 15 min before starting a test. When equipment is used continuously, it is not necessary to heat the piston and die for 15 minutes when runs of the same or similar material at the same test temperature are being measured over a continuous time frame, provided the piston and die are cleaned and re-inserted into the bore within five minutes after removal from the extrusion plastometer at the end of each test. If the piston, or die, or both, are removed from the bore for longer than five minutes, they shall be considered “cold” and the full 15 minutes heating stabilization time shall be required.

TABLE 43 Factors for Calculation of Flow Rate

Material (Unpigmented)	Temperature, °C	Piston Travel, L, cm (in.)	Factor for Calculation of Flow Rate, F^A
Polyethylene	190	2.54 (1)	826
Polyethylene	190	0.635 (0.25)	207
Polypropylene	230	2.54 (1)	799
Polypropylene	230	0.635 (0.25)	200

^A Factors calculated using melt-density values of 0.7636 g/cm³ for polyethylene and 0.7386 g/cm³ for polypropylene, as expressed in article by Zoller, Paul, “The Pressure-Volume-Temperature Properties of Polyolefins,” *Journal of Applied Polymer Science*, Vol 23, 1979, P. 1051. The base densities at 23°C for which the melt densities are reported were 0.917 g/dm³ for annealed low-density polyethylene and polypropylene homopolymer.

10.7 Adjust the automatic timing system to operate within the 6.35 ± 0.25 mm measuring range for materials with expected melt flow rates of up to 10 g/10 min, or 25.40 ± 0.25 mm measuring range for materials with expected melt flow rates of 10 g/10 min or higher and set to begin timing when the bottom of the piston foot is 46 ± 2 mm above the top of the die.

NOTE 18—It has been found that for some materials the melt flow rates obtained on a material will be different depending on which travel length is chosen; therefore, it is important to use the same measurement range to compare interlaboratory results.

10.8 Remove the piston from the bore (see Note 12). Within 60 seconds, charge the cylinder with a weighed portion of the sample in accordance with the expected flow rate (as given in Table 32), reinsert the piston and add the appropriate weight. The charging weights given in Table 32 are merely suggestions, and the actual charging weight for a specific sample, if not known, will need to be determined by trial and error. Adjust the charge weight so that the piston is in the proper position at the end of the pre-heat period. If necessary, it is acceptable to purge excess material from the cylinder bore so that the piston is in the proper position at the end of the pre-heat period. Purging of material done at conditions with greater force than testing conditions shall be completed at least 2 min prior to the expiration of the preheat period (see Note 13).

10.9 Start the test by initiating the timing device that monitors the pre-heat period, which is a period of time that allows the material to soften and begin to melt. The pre-heat period shall last for 7.0 ± 0.5 min from the completion of the charge unless otherwise stated in the materials specification.

10.10 For materials with flow rates greater than 10 g/10 min, a weight (and if needed, a piston) support must be used to prevent the piston from travelling during the pre-heat period in order to ensure that there is enough material in the bore to correctly test the material. The support is to be installed in a manner that holds the lower scribe mark of the piston approximately 25 mm above the top of the guide bushing or other suitable reference mark. Alternatively, it is acceptable for the operator to delay applying the weight to the piston. The support shall be removed or the weight applied to the piston at such a time as to allow the measurement to start within 7 ± 0.5 min of the completion of the charge. (For automated weight lowering systems, the bottom of the piston foot is held at approximately 71 mm above the top of the die.)

10.11 For materials greater than 50 g/10 min, use of a die plug is an option in addition to the piston/weight support. The die plug is inserted before charge and is removed prior to removing the piston/weight support. (**Warning**—Rapid expulsion of material when die plug is removed is hazardous.)

10.12 At the end of the pre-heat period and when automatic timing system senses that the piston has reached the pre-selected starting point (indicating that the piston land is 46 ± 2 mm from the top of the die), the automatic timing system shall begin measuring the time it takes for the piston to travel the pre-selected distance (see 10.7). If the extrudate specimen contains visible bubbles, discard the results and begin the test again (see Note 13). If the initial timed measurement was initiated outside of the tolerances of the pre-heat period or the piston position requirements, discard the results and repeat the test after readjusting the piston position after the initial purge or changing the charge weight.

10.13 Record the time to the nearest 0.01 s for the piston to complete the selected distance of travel.

10.14 Purge the remainder of the sample from the bore and follow the extrusion plastometer manufacturer's instructions for removing the die from the bore. Swab out the cylinder with cotton patches and the cylinder bore cleaning tool. Thoroughly clean the die and the piston to remove all residues (see Note 10).

11. Procedure C—Automatically Timed Flow Rate Measurement for High Flow Rate Polyolefins Using “Half” Die

11.1 Procedure:

11.1.1 Install/enable the automatic timing device on the extrusion plastometer.

11.1.2 Select conditions of temperature and load from 8-2X4.1 or in accordance with material specifications. Where multiple test conditions exist, test conditions shall be agreed upon by the cooperating laboratories. A melt density value (not bulk density) for the material is required if MFR is to be calculated from the results.

11.1.3 Use the procedure described in 10.3-10.14 with the following exceptions:

11.1.3.1 Use the “half” die as described in 5.3.2.

11.1.3.2 Adjust the timing device to operate within the 25.40 ± 0.25 mm measuring range and set to begin timing when the bottom of the piston foot is 50 ± 2 mm above the top of the die.

12. Procedure D—Multi-Weight Using Automatically Timed Flow Rate Measurement

12.1 Procedure:

12.1.1 Install/enable the automatic timing device, automatic weight lifting/lowering device and multi-weight (FRR) accessory on the extrusion plastometer. The multi-weight test shall be made in either increasing weight or decreasing weight conditions. Follow the equipment manufacturer's instructions for installation and operation.

12.1.2 Configure the multi-weight (FRR) accessory to take at least two MFR determinations at each load condition used before changing to the next test load. After switching load conditions, achieve stable flow by allowing sufficient piston travel or time to elapse before beginning measurements (see Note 19). Piston travel distances shall be chosen so that at least 2 seconds elapse during the measurement and that the distances are determined within ± 0.4 %.

NOTE 19—Normally, 5 mm of piston travel or 2 min is sufficient to obtain stable flow after changing test loads.

12.1.3 Adjust the automatic timing device to make multiple test measurements as required and set to begin timing the first measurement when the bottom of the piston foot is 46 ± 2 mm above the top of the die. Do not take readings below 18.35 mm above the top of the die.

12.1.4 Inspect the extrusion plastometer for cleanliness (see Note 10). All surfaces of the cylinder bore, die and piston shall be free of any residue from previous tests.

12.1.5 Check the die bore diameter at frequent intervals with appropriately sized go/no-go gauges (checked with die at $23 \pm 5^\circ\text{C}$) to verify that the die is within the tolerances given in 5.3.1. Visually examine the die bore to verify that it is not scratched or damaged. Also visually inspect the land of the piston foot to verify that it is not scratched or damaged and use a calibrated micrometer to verify that the dimensions are within the tolerances given in 5.4.1 (see Note 11).

12.1.6 Set the temperature in accordance with the manufacturer's instructions.

12.1.7 A melt density value (see Table 32) for the material is required in order to calculate MFR for the individual determinations.

12.1.8 Insert the die and the piston into the bore. Allow the temperature of the cylinder with the piston and die in place to stabilize within $\pm 0.2^\circ\text{C}$ of the selected test temperature for at least 15 min before starting a test. When equipment is used continuously, it is not necessary to heat the piston and die for 15 minutes when runs of the same or similar material at the same test temperature are being measured over a continuous time frame, provided the piston and die are cleaned and re-inserted into the bore within five minutes after removal from the extrusion plastometer at the end of each test. If the piston and/or die are removed from the bore for longer than five minutes, they shall be considered "cold" and the full 15 minutes heating stabilization time shall be required.

12.1.9 Remove the piston from the bore (see Note 12). Within 60 seconds, charge the cylinder with a weighed portion of the sample in accordance with the expected melt flow rate (as given in Table 32), reinsert the piston and use the weight lifting and lowering device to add the test load to the piston.

12.1.10 Some materials, particularly those with expected melt flow rates less than 10g/10 min during the first measurement period require the operator to purge some material to a position that insures subsequent travel of the piston will activate the timing device at the desired starting point for the first measurement within 7.0 ± 0.5 min after the completion of the charge. The lower scribe mark of the piston shall be at least 25 mm above the top of the cylinder after purging. Any purging must be completed at least 2 min prior to start of the test Melt Flow Rates.

12.1.11 Materials with higher expected flow rates will require that the weight and piston support be used after charging the material. For Procedure D, this can be accomplished with the automatic weight lifting/lowering device. The support shall be removed at such a time as to allow the automatic timing device to activate at the starting point for the first measurement within 7.0 ± 0.5 min after the completion of the charge. Only use the piston support if there is excessive material flow (see Note 15).

12.1.12 If a die plug is used to prevent excessive leakage before the test, for materials with a melt flow rate greater than 50 g/10 min, then the die plug is to be inserted before the charge and removed prior to removing the piston/weight support. The initial charge shall be adjusted to ensure appropriate measurement loads based on suggestions in Table 32. If the timer is not activated within 7 ± 0.5 min after the completion of the charge the test must be repeated with readjusted charge weights.

12.1.13 Record the time, to the nearest 0.01 s, for the individual piston travel determinations measured for each test load.

12.1.14 Repeat the above for any additional test loads.

12.1.15 Purge the remainder of the sample from the bore and follow the extrusion plastometer manufacturer's instructions for removing the die from the bore. Swab out the cylinder with cotton patches and the cylinder bore cleaning tool. Thoroughly clean the die and the piston to remove all residues (see Note 10).

13. Calculation of Flow Rate

13.1 Calculation for Procedures B and C:

13.1.1 Calculate the flow rate in grams per 10 min or volume rate in cm^3 per 10 min as follows (see Note 20):

$$\text{Melt flow rate} = (426 \times L \times d)/t$$

or

$$\text{Melt volume rate} = 426 \times L/t$$

where:

L = length, cm, of calibrated piston travel,

d = melt density of resin, g/cm^3 , at test temperature, (see reference under Table 3 and Table 4),

\underline{d} = melt density of resin, g/cm^3 , at test temperature, (see reference under Table 2 and Table 3),

t = time, seconds, of piston travel for length L , and

426 = mean of areas, cm^2 , of piston and cylinder $\times 600$.

NOTE 20—Factors that may be substituted in the following equation are given for some materials in Table 43.

$$\text{Flow rate, g/10min} = F/t$$

where: