



Designation: ~~D3412—07~~ D3412/D3412M – 13

Standard Test Method for Coefficient of Friction, Yarn to Yarn¹

This standard is issued under the fixed designation ~~D3412~~D3412/D3412M; the number immediately following the designation indicates the year of original adoption or, in the case of revision, the year of last revision. A number in parentheses indicates the year of last reappraisal. A superscript epsilon (ϵ) indicates an editorial change since the last revision or reappraisal.

1. Scope

1.1 This test method covers the measurement of frictional properties for both continuous filament and spun-staple yarns under boundary friction conditions.

1.2 This test method has been used with yarns having linear densities ranging from 1.5 to ~~200~~400 tex, but may be used with yarns outside these ranges (~~+5[15 to 1800 denier]~~:3600 denier).

NOTE 1—For coefficient of friction, yarn to metal, see Test Method ~~D3108~~D3108M.

1.3 The values stated in either SI units or inch-pound units are to be regarded separately as the standard. The ~~inch-pound units given in parentheses are for information only~~ values stated in each system may not be exact equivalents; therefore, each system shall be used independently of the other. Combining values from the two systems may result in non-conformance with the standard.

1.4 *This standard does not purport to address all of the safety concerns, if any, associated with its use. It is the responsibility of the user of this standard to establish appropriate safety and health practices and determine the applicability of regulatory limitations prior to use.*

2. Referenced Documents

2.1 *ASTM Standards:*²

[D123 Terminology Relating to Textiles](#)

[D1776 Practice for Conditioning and Testing Textiles](#)

[D1907 Test Method for Linear Density of Yarn \(Yarn Number\) by the Skein Method](#)

[D2258 Practice for Sampling Yarn for Testing](#)

[D3108M Test Method for Coefficient of Friction, Yarn to Solid Material](#)

[D4849 Terminology Related to Yarns and Fibers](#)

3. Terminology

3.1 For all terminology relating to D13.58, Yarns and Fibers, refer to Terminology [D4849](#).

3.2 For all other terminology related to textiles, refer to Terminology [D123](#).

4. Summary of Test Method

4.1 A length of yarn is moved at a known speed in contact with itself or similar yarn at a specified wrap angle. The input and output tensions are measured and the coefficient of friction calculated. Alternatively, apparatus may be used in which the ratio of input to output tension is measured allowing the coefficient of friction to be indicated directly.

4.2 ~~Two~~Three optional procedures are included. Option 1 is based on the Twisted Strand Method, using a wrap angle of 15.71 rad (~~900°~~:900°). Option 2 is based on the Capstan Method, using a wrap angle of 3.14 radians (~~180°~~:180°). Option 3 is based on the Fixed Yarn-Body Capstan Method, using a wrap angle of 3.14 radians [180°].

NOTE 2—Editions of Test Method ~~D3412~~D3412/D3412M prior to the 1986 revision incorrectly stated the wrap angle for Option 1 to be 18.85 rad. This is incorrect, since 3 turns of the swivel pulley do not result in a wrap angle of 18.85 radians. This has now been corrected to 15.71 rad. This should be taken into account in comparing with earlier results.

¹ This test method is under the jurisdiction of ASTM Committee [D13](#) on Textiles and is the direct responsibility of Subcommittee [D13.58](#) on Yarns and Fibers. Current edition approved ~~Jan. 1, 2007~~July 1, 2013. Published ~~January 2007~~August 2013. Originally approved in 1975T. Last previous edition approved in ~~2004~~2007 as ~~D3412—04~~D3412 – 07. DOI: ~~10.1520/D3412-07~~10.1520/D3412_D3412M-13.

² For referenced ASTM standards, visit the ASTM website, www.astm.org, or contact ASTM Customer Service at service@astm.org. For *Annual Book of ASTM Standards* volume information, refer to the standard's Document Summary page on the ASTM website.

5. Significance and Use

5.1 This test method for testing yarn-to-yarn friction is being used, but is not recommended, for acceptance testing of commercial shipments since between-laboratory precision is known to be poor.

5.1.1 In some cases, the purchaser and supplier may have to test a commercial shipment of one or more specific materials by the best available method even though the method has not been recommended for acceptance testing of commercial shipments. In case of a dispute arising from differences in reported test results when using Test Method ~~D3412~~D3412/D3412M for acceptance testing of commercial shipments, the purchaser and the supplier should conduct comparative tests to determine if there is a statistical bias between their laboratories. Competent statistical assistance is recommended for the investigation of bias. As a minimum, the two parties should take a group of test specimens that are as homogeneous as possible and that are from a lot of material of the type in question. The test specimens should then be randomly assigned in equal numbers to each laboratory for testing. The average results from the two laboratories should be compared using Student's *t*-test for unpaired data and an acceptable probability level chosen by the two parties before the testing is begun. If a bias is found, either its cause must be found and corrected or the purchaser and the supplier must agree to interpret future test results with consideration to the known bias.

5.2 This test method is intended for the determination of yarn-to-yarn boundary friction coefficients measured over a specified length of yarn.

5.3 The test method is useful for quality control, research, and the characterization of yarn boundary lubricants.

NOTE 3—Because the geometry of the yarns is different, Options 1 and 2 should not be expected to give the same numerical values on the same yarns.

6. Apparatus

6.1 *Option 1 (Twisted Strand Method)*—A schematic diagram of the elements required for twisted strand friction measurement is shown in Fig. 1. The yarn is run over upper pulleys and under a lower pulley and is intertwined between these pulleys. One end of the yarn (output) is taken up at a controlled rate. The other end of yarn (input) is maintained at a controlled tension. The number of intertwisting wraps, the apex angle between the input and output yarns, and the input and output tensions are precisely known or recorded. From these data the coefficient of yarn-on-yarn friction is calculated. The required elements are:

6.1.1 *Friction Testing Apparatus (Indirect)*³—Apparatus in which the input tension is measured, or controlled to a set value, the output tension is measured, and the coefficient of friction is calculated within or outside the apparatus.

6.1.1.1 *Yarn Input Tension Control*—A means of controlling the yarn input tension to the nearest 5 % is required. A demand-feed apparatus tensioned with a fixed weight is suitable.

6.1.1.2 *Yarn Input Tension Measurement*—The yarn input tension is measured to within $\pm 5.0 \pm 1.0$ mN (± 0.5 gf); [± 0.1 gf], using a suitable tension gage producing an electrical signal. The signal is recorded as millinewtons (grams-force) [grams-force], or is used in combination with the yarn output tension measured to calculate the coefficient of friction. If a demand-feed apparatus tensioned with a precise, known fixed mass is used, the yarn input tension need not be constantly measured and recorded.

6.1.1.3 *Yarn Output Tension Measurement*—Yarn output tension is measured to within $\pm 5.0 \pm 1.0$ mN (± 0.5 gf); [± 0.1 gf], using a suitable tension gage producing an electrical signal. The signal is recorded as millinewtons, (grams-force); millinewtons [grams-force], or is used in combination with the yarn input tension setting or measurement to calculate the coefficient of friction.

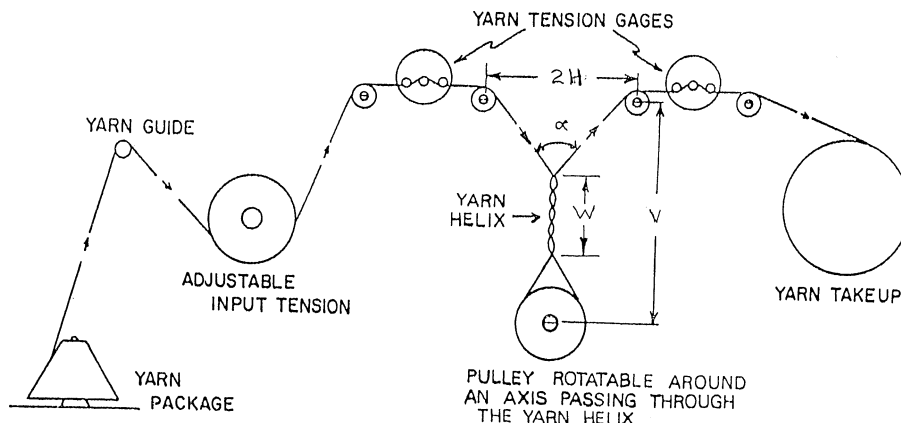

FIG. 1 Twisted Strand Yarn-to-Yarn Friction Apparatus—Twisted-Yarn Method

³ Equipment meeting these requirements may be obtained commercially from: Custom Scientific Instruments Inc, 13 Wing Drive, Cedar Knolls, NJ 07292, and Rothschild-Messinstruments, Traubstr 3, 8002 Zurich, Switzerland, represented in the U.S. by Lawson Hemphill Sales Inc, PO Drawer 6388, Spartanburg, SC 29304.

6.1.2 *Friction Testing Apparatus (Direct)*⁴—Apparatus in which the ratio of output to input tensions are compared directly and the coefficient of friction is indicated on a scale.

6.1.3 *Auxilliary Equipment (Indirect and Direct):*

6.1.3.1 *Guide Pulley Arrangement*—The upper and lower pulleys shall be of the same diameter. The recommended pulley diameter is ~~38 mm (1.5 in.)~~, ranges between 20 and 50 mm [0.8 and 2 in.]. The separation distance between the upper pulleys, $2H$, shall be 140 ± 25 mm [~~5.5 [5.5 ± 0.1 in.]~~0.25 in.]. The separation distance between the axis of the lower pulley and a line connecting the upper pulley axes, V , shall be 280 ± 25 mm [~~11 [11 ± 0.1 in.]~~0.25 in.]. All pulleys shall be in the same plane. The lower pulley may optionally be mounted so that it can be swiveled around an axis at right angles to its axis of rotation and then fixed in position in the same plane as the upper pulleys.

6.1.3.2 *Drive Unit*—The yarn takeup shall run between ~~200.1 and 400~~200 mm/min [~~0.75 [0.004 and 4.0 in./min]~~8 in./min].

6.2 *Option 2 (Capstan Method)*—A schematic diagram of the elements required for the Capstan Method is shown in Fig. 2. Suitable elements are:

6.2.1 *Cylinder*—A rotating mandrel of 50 ± 2 mm [~~2.0 [2.0 ± 0.1 in.]~~in.] outside diameter.

6.2.2 *Drive Unit*—A mechanism designed to rotate the cylinder at a surface speed of 20 ± 1 mm/min [~~0.75 [0.75 ± 0.04 in./mm]~~in./mm].

6.2.3 *Winding Unit*—A device to wrap the yarn on the surface of the cylinder. A helix angle of 0.2 to 0.3 rad [~~10 to 15°~~15°] is needed to prevent burrowing by the hanging strand of yarn.

6.2.4 *Tension Gauge*—~~Gauge~~—A suitable tension gauge, producing an electrical signal, to measure the yarn output tension which is recorded as millinewtons or after calculation as coefficient of friction.

6.2.5 *Weights*—A set of weights or other device to preset the input tension.

NOTE 4—Measured stick-slip differentials are greatly dependent on tension transducer spring constants, yarn modulus, and recorder frequency responses. If interlaboratory checks are required, the same type of tension transducer and recorder should be used and the distance between the transducer and the hanging weight to center line of the mandrel must be specified.

6.3 *Option 3 (Fixed Yarn-Body Capstan Method)*—A schematic diagram of the elements required for the Fixed Yarn Body Method is shown in Fig. 3. Suitable elements are:

6.3.1 *Friction Testing Apparatus*—Apparatus in which the input tension is measured, or controlled to a set value, the output tension is measured, and the coefficient of friction is calculated within or outside the apparatus.

6.3.1.1 *Yarn Input Tension Measurement*—The yarn input tension is measured to within ± 1.0 mN [± 0.1 gf], using a suitable tension gauge producing an electrical signal. The signal is recorded as millinewtons or centinewtons (grams-force), or is used in combination with the yarn output tension measured to calculate the coefficient of friction. If a demand-feed apparatus tensioned with a precise, known fixed mass is used, the yarn input tension need not be constantly measured and recorded.

6.3.1.2 *Yarn Output Tension Measurement*—Yarn output tension is measured to within ± 1.0 mN [± 0.1 gf], using a suitable tension gauge producing an electrical signal. The signal is recorded as millinewtons or centinewtons, (grams-force), or is used in combination with the yarn input tension setting or measurement to calculate the coefficient of friction.

6.3.2 *Drive Unit*—The yarn takeup shall run between 0.1 and 200 mm/min [0.0039 and 7.9 in./min].

6.3.3 *Cylinder*—A fixed mandrel capable of fixing a bobbin of 50 ± 5 mm [2.0 ± 0.25 in.] outside diameter.

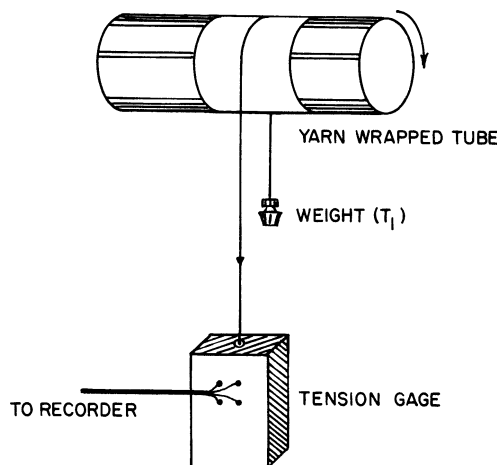

FIG. 2 Yarn-to-Yarn Friction Apparatus—Capstan Method

⁴ Equipment meeting these requirements may be obtained commercially from: Rothschild-Messinstruments, Traubstr 3, 8002 Zurich, Switzerland, represented in the U.S. by Lawson Hemphill Sales Inc, PO Drawer 6388, Spartanburg, SC 29304, and Shirley Developments Ltd, PO Box 6, Didsbury, Manchester M20 8SA, England, represented in the U.S. by Lawson Hemphill Sales Inc, PO Drawer 6388, Spartanburg, SC 29304.