**Diesel fuel — Assessment of
lubricity using the high-frequency
reciprocating rig (HFRR) —**

**Part 1:
Test method**

*Carburant diesel — Évaluation du pouvoir lubrifiant au banc
alternatif à haute fréquence (HFRR) —
Partie 1: Méthode d'essai*

[ISO 12156-1:2023](https://standards.iteh.ai/catalog/standards/sist/ab05b213-d83d-4d9a-98ec-8ab4ccf0e4a5/iso-12156-1-2023)

<https://standards.iteh.ai/catalog/standards/sist/ab05b213-d83d-4d9a-98ec-8ab4ccf0e4a5/iso-12156-1-2023>



iTeh STANDARD PREVIEW
(standards.iteh.ai)

ISO 12156-1:2023

<https://standards.iteh.ai/catalog/standards/sist/ab05b213-d83d-4d9a-98ec-8ab4ccf0e4a5/iso-12156-1-2023>



COPYRIGHT PROTECTED DOCUMENT

© ISO 2023

All rights reserved. Unless otherwise specified, or required in the context of its implementation, no part of this publication may be reproduced or utilized otherwise in any form or by any means, electronic or mechanical, including photocopying, or posting on the internet or an intranet, without prior written permission. Permission can be requested from either ISO at the address below or ISO's member body in the country of the requester.

ISO copyright office
CP 401 • Ch. de Blandonnet 8
CH-1214 Vernier, Geneva
Phone: +41 22 749 01 11
Email: copyright@iso.org
Website: www.iso.org

Published in Switzerland

Contents

	Page
Foreword.....	iv
Introduction.....	v
1 Scope.....	1
2 Normative references.....	1
3 Terms and definitions.....	1
4 Principle.....	2
5 Reagents and materials.....	2
6 Apparatus.....	3
7 Sampling.....	5
8 Preparation and calibration.....	6
8.1 Preparation of apparatus.....	6
8.1.1 Test plates and balls.....	6
8.1.2 Hardware.....	6
8.2 Calibration and correction.....	6
8.2.1 Temperature.....	6
8.2.2 Frequency.....	6
8.2.3 Stroke length.....	6
8.2.4 Test duration.....	6
8.2.5 Test rig performance.....	6
9 Test procedure.....	7
10 Measurement of wear scar.....	8
11 Test results.....	8
12 Precision.....	8
12.1 General.....	8
12.2 Repeatability, <i>r</i>	8
12.3 Reproducibility, <i>R</i>	9
13 Test report.....	9
Annex A (informative) Measurement of HFRR wear scars.....	10
Bibliography.....	13

Foreword

ISO (the International Organization for Standardization) is a worldwide federation of national standards bodies (ISO member bodies). The work of preparing International Standards is normally carried out through ISO technical committees. Each member body interested in a subject for which a technical committee has been established has the right to be represented on that committee. International organizations, governmental and non-governmental, in liaison with ISO, also take part in the work. ISO collaborates closely with the International Electrotechnical Commission (IEC) on all matters of electrotechnical standardization.

The procedures used to develop this document and those intended for its further maintenance are described in the ISO/IEC Directives, Part 1. In particular, the different approval criteria needed for the different types of ISO document should be noted. This document was drafted in accordance with the editorial rules of the ISO/IEC Directives, Part 2 (see www.iso.org/directives).

ISO draws attention to the possibility that the implementation of this document may involve the use of (a) patent(s). ISO takes no position concerning the evidence, validity or applicability of any claimed patent rights in respect thereof. As of the date of publication of this document, ISO had not received notice of (a) patent(s) which may be required to implement this document. However, implementers are cautioned that this may not represent the latest information, which may be obtained from the patent database available at www.iso.org/patents. ISO shall not be held responsible for identifying any or all such patent rights.

Any trade name used in this document is information given for the convenience of users and does not constitute an endorsement.

For an explanation of the voluntary nature of standards, the meaning of ISO specific terms and expressions related to conformity assessment, as well as information about ISO's adherence to the World Trade Organization (WTO) principles in the Technical Barriers to Trade (TBT), see www.iso.org/iso/foreword.html.

This document was prepared by Technical Committee ISO/TC 28, *Petroleum and related products, fuels and lubricants from natural or synthetic sources*, in collaboration with the European Committee for Standardization (CEN) Technical Committee CEN/TC 19, *Gaseous and liquid fuels, lubricants and related products of petroleum, synthetic and biological origin*, in accordance with the Agreement on technical cooperation between ISO and CEN (Vienna Agreement).

This fifth edition cancels and replaces the fourth edition (ISO 12156-1:2018), which has been technically revised.

The main changes are as follows:

- the scope has been broadened;
- a new precision statement has been added using linear transformation as required by ISO 4259-1;
- “Method B” Visual Observation has been removed.

A list of all parts in the ISO 12156 series can be found on the ISO website.

Any feedback or questions on this document should be directed to the user's national standards body. A complete listing of these bodies can be found at www.iso.org/members.html.

Introduction

All diesel fuel injection equipment has some reliance on diesel fuel as a lubricant. Wear due to excessive friction resulting in shortened life of engine components, such as diesel fuel injection pumps and injectors, has sometimes been ascribed to lack of lubricity in the fuel.

The relationship of test results to diesel injection equipment component distress due to wear has been demonstrated for some fuel/hardware combinations where boundary lubrication is a factor in the operation of the component. Test results from fuels tested using this procedure have been found to correlate with many fuel/hardware combinations and provide an adequate prediction of the lubricating quality of the fuel. The correlation of biodiesel blends has been validated through 15 years of field experience and anecdotal data.

iTeh STANDARD PREVIEW
(standards.iteh.ai)

[ISO 12156-1:2023](https://standards.iteh.ai/catalog/standards/sist/ab05b213-d83d-4d9a-98ec-8ab4ccf0e4a5/iso-12156-1-2023)

<https://standards.iteh.ai/catalog/standards/sist/ab05b213-d83d-4d9a-98ec-8ab4ccf0e4a5/iso-12156-1-2023>

Diesel fuel — Assessment of lubricity using the high-frequency reciprocating rig (HFRR) —

Part 1: Test method

WARNING — Application of this document may involve the use of hazardous materials, operations, and equipment. This document does not purport to address all the safety problems associated with its use. It is the responsibility of the user of this document to establish appropriate safety and health practices, and to determine the applicability of any other restrictions for this purpose.

1 Scope

This document specifies a test method using the high-frequency reciprocating rig (HFRR) with a digital camera, for assessing the lubricating property of petroleum-based middle distillate fuels, paraffinic diesel fuels, and biodiesel blends, with or without lubricity enhancing additives, and with HFRR wear scar diameters (WSDs) of 350 µm to 700 µm.

This test method applies to fuels used in diesel engines.

NOTE It is not known if this test method can predict the performance of all additive/fuel combinations.

2 Normative references

The following documents are referred to in the text in such a way that some or all of their content constitutes requirements of this document. For dated references, only the edition cited applies. For undated references, the latest edition of the referenced document (including any amendments) applies.

ISO 683-17, *Heat-treated steels, alloy steels and free-cutting steels — Part 17: Ball and roller bearing steels*

ISO 3170, *Petroleum liquids — Manual sampling*

ISO 3171, *Petroleum liquids — Automatic pipeline sampling*

ISO 3290-1, *Rolling bearings — Balls — Part 1: Steel balls*

ISO 5272, *Toluene for industrial use — Specifications*

ISO 6507-1, *Metallic materials — Vickers hardness test — Part 1: Test method*

ISO 6508-1, *Metallic materials — Rockwell hardness test — Part 1: Test method*

ISO 21920-3, *Geometrical product specifications (GPS) — Surface texture: Profile — Part 3: Specification operators*

ASTM D4306:2020, *Practice for Aviation Fuel Sample Containers for Tests Affected by Trace Contamination*

3 Terms and definitions

For the purposes of this document, the following terms and definitions apply.

ISO and IEC maintain terminology databases for use in standardization at the following addresses:

- ISO Online browsing platform: available at <https://www.iso.org/obp>
- IEC Electropedia: available at <https://www.electropedia.org/>

3.1

boundary lubrication

condition in which the friction and wear between two surfaces in relative motion are determined by the properties of the surfaces and the properties of the contacting fluid, other than bulk viscosity

Note 1 to entry: Metal to metal contact occurs and the chemistry of the system is involved. Physically adsorbed or chemically reacted soft films (usually very thin) support contact loads. As a result, some wear is inevitable.

3.2

lubricity

qualitative term describing the ability of a fluid to affect friction between, and wear to, surfaces in relative motion under load

Note 1 to entry: In this test method, the lubricity of a fluid is evaluated by the wear scar, measured in micrometres, produced on an oscillating ball from contact with a stationary disk immersed in the fluid operating under closely controlled conditions.

3.3

wear scar diameter

WSD

mean diameter of the wear scar produced on the test ball

4 Principle

A sample of the fluid under test is placed in a test reservoir which is maintained at the specified test temperature. A fixed steel ball is held in a vertically mounted chuck and forced against a horizontally mounted stationary steel plate with an applied load. The test ball is oscillated at a fixed frequency and stroke length while the interface with the plate is fully immersed in the fluid. The metallurgies of the ball and plate, test fluid temperature, load, frequency, stroke length, and the ambient air conditions of temperature and humidity during the test are specified. The wear scar generated on the test ball is taken as a measure of the fluid lubricity.

5 Reagents and materials

5.1 Compressed air, if required for drying the equipment listed in [8.1.1](#) and [8.1.2](#). The compressed air shall be supplied at a pressure of 140 kPa to 210 kPa, and contain less than 0,1 ml/m³ hydrocarbons, and less than 50 ml/m³ water.

WARNING — Use with extreme caution in the presence of combustible material.

5.2 Acetone, analytical reagent grade.

WARNING — Extremely flammable. Vapours can cause flash fire.

5.3 Reference fluids¹⁾

WARNING — Flammable.

1) Reference fluids A and B are available from ASTM Monitoring Center (<https://www.astmtmc.org>). This information is given for the convenience of users of this document and does not constitute an endorsement by ISO of the products named. Equivalent products may be used if they can be shown to lead to the same results.

Two reference fluids, Fluid “A” – High (Good) lubricity reference and Fluid “B” – Low (Poor) lubricity reference, shall be used for verifying the performance of the test apparatus. They shall be clearly marked with the HFRR value (WSD) and its expanded uncertainty, expressed in micrometres. Store reference fluids in clean, borosilicate glass with an aluminium foil-lined insert cap or fully epoxy-lined metal container. Store in a dark location.

5.4 **Gloves**, appropriate for the reagents used.

5.5 **Heptane**, reagent grade.

WARNING — Extremely flammable. Vapours can cause flash fire.

5.6 **Isooctane**, reagent grade.

WARNING — Extremely flammable. Vapours can cause flash fire.

5.7 **2-propanol**, reagent grade.

WARNING — Extremely flammable. Vapours can cause flash fire.

5.8 **Wiper**, wiping tissue, light-duty, lint-free, hydrocarbon-free, disposable.

5.9 **Toluene**, in accordance with ISO 5272.

WARNING — Extremely flammable. Vapours can cause flash fire. Can be fatal if swallowed and enters airways. Can cause drowsiness or dizziness. Suspected of damaging unborn children. Can cause damage to organs through prolonged or repeated exposure.

6 Apparatus

6.1 **Test apparatus**²⁾ (see [Figure 1](#)), capable of engaging a steel ball loaded against a stationary steel plate with an applied load and oscillating at a fixed frequency and stroke length while the contact interface is fully immersed in a fluid according to the test conditions given in [Table 1](#).

Table 1 — Test conditions

Parameter	Value
Fluid volume, ml	2 ± 0,2
Stroke length, mm	1 ± 0,02
Frequency, Hz	50 ± 1
Laboratory air ^a	See Figure 2
Fluid temperature, °C	60 ± 2
Test mass ^b , g	200 ± 1
Test duration, min	75 ± 0,1
Reservoir surface area, mm ²	600 ± 100
^a Laboratory air conditions as measured between 0,1 m and 0,25 m of the fluid reservoir shall be controlled to the acceptable range of conditions as shown in Figure 2 .	
^b Total mass including fixing elements.	

2) HFRR units of PCS Instruments (<https://pcs-instruments.com>), have been found satisfactory. This information is given for the convenience of users of this document and does not constitute an endorsement by ISO of these products. Equivalent products may be used if they can be shown to lead to the same results.

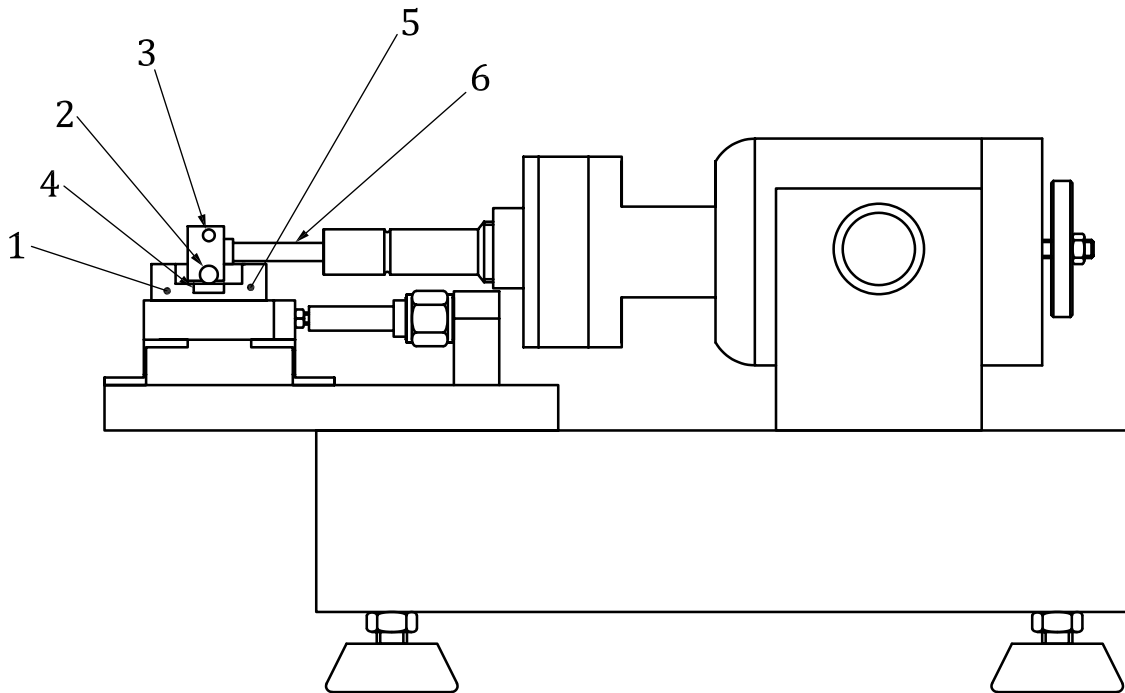

Key

- | | | | |
|---|-----------------|---|--------------------|
| 1 | fluid reservoir | 4 | test plate |
| 2 | test ball | 5 | heating bath |
| 3 | test mass | 6 | oscillating motion |

Figure 1 — Schematic of the high-frequency reciprocating rig

The fluid reservoir shall be capable of holding a test plate in a rigid manner and shall also contain the test fluid. The temperature of this reservoir, and consequently the test fluid contained in it, should be achieved by means of an electrically controlled heater pad to which the fluid reservoir is closely attached.

The apparatus control unit for controlling variable parameters shall include provision for electronic data storage and retrieval, and for electronic calibration of the stroke length.

6.2 Test plate³⁾, made of 100Cr6 steel as specified in ISO 683-17, machined from annealed rod, having a Vickers hardness “HV 30” scale number of 190 to 210 in accordance with ISO 6507-1. It shall be lapped and polished to a surface finish of Ra < 0,02 µm, measured in accordance with ISO 21920-3.

6.3 Test ball³⁾, 6,00 mm diameter, grade 28 (G28) in accordance with ISO 3290-1 of 100Cr6 steel as specified in ISO 683-17. It shall have a Rockwell hardness “C” scale (HRC) number of 58 to 66 in accordance with ISO 6508-1.

6.4 Microscope with digital camera³⁾, capable of 100 × magnification, installed and calibrated according to the manufacturer's instructions, capable of capturing a crisp image of the wear scar. Camera system resolution should be a minimum of 2 048 pixels × 1 536 pixels. The measurement

3) Suitable test specimens and microscopes are available from PCS Instruments (<https://pcs-instruments.com>). This information is given for the convenience of users of this document and does not constitute an endorsement by ISO of this product. Equivalent products may be used if they can be shown to lead to the same results.

system should allow horizontal and vertical measurement devices or cursors to be positioned at the wear scar boundaries with an accuracy of 1 µm.

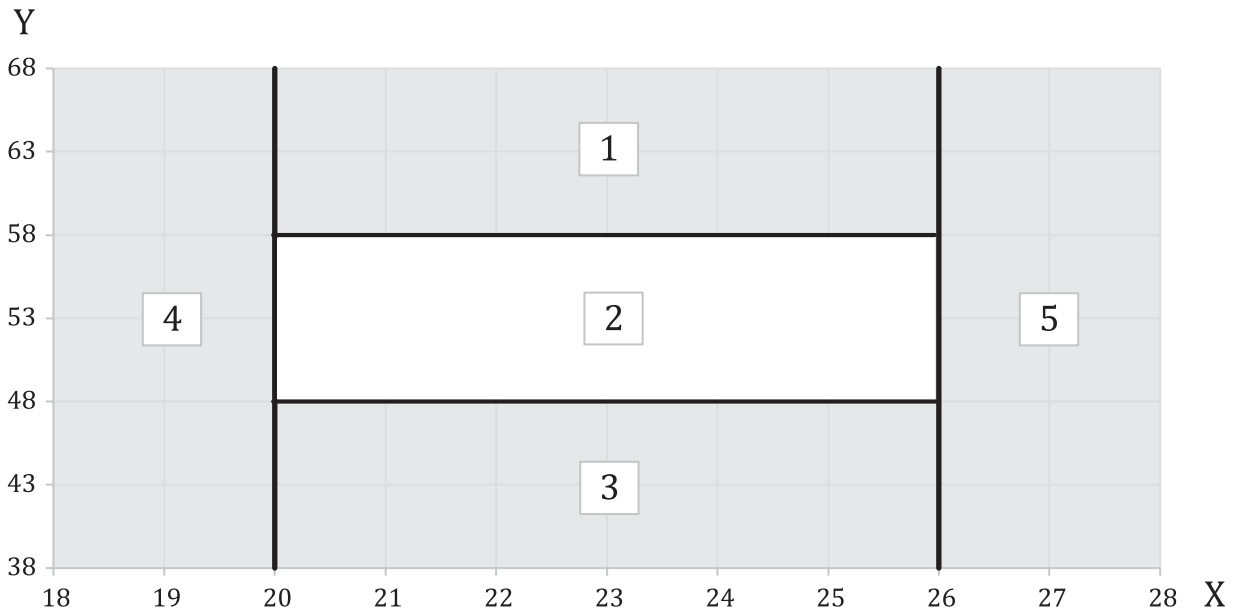

Key

X	air temperature, °C	3	unacceptable range of conditions — too dry
Y	relative humidity, %	4	unacceptable range of conditions — too cold
1	unacceptable range of conditions — too moist	5	unacceptable range of conditions — too warm
2	acceptable range of conditions		

Figure 2 — Laboratory air conditions

<https://standards.iteh.ai/catalog/standards/sist/ab05b213-d83d-4d9a-98ec-8ab4ccf0e4a5/iso-12156-1-2023>

6.5 Desiccator, containing a drying agent, capable of storing test plates, balls, and hardware.

6.6 Cleaning bath, ultrasonic type, with a seamless stainless-steel tank of adequate capacity and a cleaning power of 40 W or greater.

6.7 Time-measuring device, mechanical or electronic, capable of measuring $(75 \pm 0,1)$ min.

7 Sampling

7.1 Unless otherwise specified, samples shall be taken in accordance with ISO 3170 or ISO 3171.

7.2 Because of the sensitivity of lubricity measurements to trace materials, sample containers shall be only fully epoxy-lined metal or amber borosilicate glass with an aluminium foil-lined insert cap, cleaned and rinsed thoroughly at least three times with the product to be sampled before use, as specified under ASTM D4306:2020, 6.7.

7.3 New sample containers are preferred, but if not available, ASTM D4306:2020, 6.7 gives guidance on suitable cleaning procedures for each type of container.