

---

**INTERNATIONAL STANDARD**



**3314**

---

INTERNATIONAL ORGANIZATION FOR STANDARDIZATION • МЕЖДУНАРОДНАЯ ОРГАНИЗАЦИЯ ПО СТАНДАРТИЗАЦИИ • ORGANISATION INTERNATIONALE DE NORMALISATION

---

**Shell drills with taper bore (taper bore 1 : 30 (included))  
with slot drive**

*Forets creux à alésage conique (conicité 1 : 30) à entraînement par tenons*

First edition — 1975-05-15

**iTeh STANDARD PREVIEW**  
**(standards.iteh.ai)**

[ISO 3314:1975](https://standards.iteh.ai/catalog/standards/sist/1418c28f-a2ff-4ec3-b6ea-8011b01614b/iso-3314-1975)

<https://standards.iteh.ai/catalog/standards/sist/1418c28f-a2ff-4ec3-b6ea-8011b01614b/iso-3314-1975>



---

UDC 621.951.47

Ref. No. ISO 3314-1975 (E)

**Descriptors :** tools, drill bits, taper bore, specifications, dimensions.

## FOREWORD

ISO (the International Organization for Standardization) is a worldwide federation of national standards institutes (ISO Member Bodies). The work of developing International Standards is carried out through ISO Technical Committees. Every Member Body interested in a subject for which a Technical Committee has been set up has the right to be represented on that Committee. International organizations, governmental and non-governmental, in liaison with ISO, also take part in the work.

Draft International Standards adopted by the Technical Committees are circulated to the Member Bodies for approval before their acceptance as International Standards by the ISO Council.

International Standard ISO 3314 was drawn up by Technical Committee ISO/TC 29, *Small tools*, and circulated to the Member Bodies in February 1974.

It has been approved by the Member Bodies of the following countries :

Australia	India	Switzerland
Austria	Israel	Turkey
Belgium	Japan	United Kingdom
Bulgaria	Netherlands	U.S.A.
Egypt, Arab Rep. of	Poland	U.S.S.R.
France	Romania	Yugoslavia
Germany	South Africa, Rep. of	
Hungary	Spain	

The Member Bodies of the following countries expressed disapproval of the document on technical grounds :

Czechoslovakia  
Italy  
Sweden

# Shell drills with taper bore (taper bore 1 : 30 (included)) with slot drive

## iTeh STANDARD PREVIEW (standards.iteh.ai)

### 1 SCOPE AND FIELD OF APPLICATION

This International Standard specifies the dimensions of shell drills with taper bore, taper bore 1 : 30 (included), with slot drive, for use on the corresponding arbors for shell reamers in accordance with ISO 2402. (The dimensions of these arbors are repeated for information in the annex.)

It supplements ISO 235/1.

It covers only metric dimensions, regarded as the only recommended dimensions in the future, for this type of drill :

- for shell drills with outside diameters above 23,6 mm up to and including 101,6 mm having taper bores with large end diameters  $d_1$  from 13 to 40 mm;
- for shell drill slots, in order to ensure interchangeability of shell drills and the corresponding arbors shown in ISO 2402, and also details of a method of checking the taper bore.

A list of recommended stocked sizes of shell drills is given in the annex.

Unless otherwise stated, these drills will be right-hand cutting.

### 2 REFERENCES

ISO 235/1, *Parallel shank twist drills, jobber and stub series, Morse taper shank twist drills and core drills.*

ISO 2402, *Shell reamers with taper bore (taper bore 1 : 30 (included)) with slot drive and arbors for shell reamers.*

### 3 GENERAL DIMENSIONS AND FITTING DIMENSIONS

The range of outside diameters does not correspond exactly to the ranges already established in ISO 2402 for shell reamers, and it has also been found necessary to depart from the outside diameter/bore diameter relationship established for shell reamers, in order to maintain a wall thickness which will give sufficient strength to the drills since the depth of the flutes of shell drills is very much greater than those of shell reamers.

The numbers of flutes are not specified, being left to the discretion of the manufacturer.

4 SHELL DRILLS WITH TAPER BORE (TAPER 1 : 30 (INCLUDED)) WITH SLOT DRIVE

TABLE 1

Dimensions in millimetres

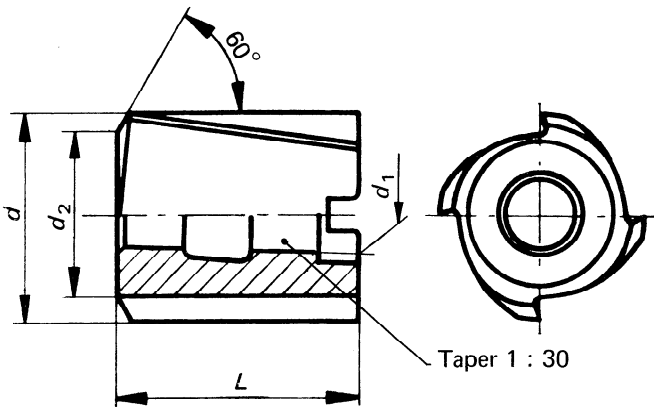

Diameter ranges <i>d</i> (h8)		<i>d</i> <sub>1</sub>	<i>d</i> <sub>2</sub>	<i>L</i>
above	up to and including			
23,6	35,5	13	<i>d</i> - 5	45
35,5	45	16	<i>d</i> - 6	50
45	53	19	<i>d</i> - 8	56
53	63	22	<i>d</i> - 9	63
63	75	27	<i>d</i> - 11	71
75	90	32	<i>d</i> - 13	80
90	101,6	40	<i>d</i> - 15	90

iTeh STANDARD PREVIEW  
(standards.iteh.ai)

For tolerance on *d*<sub>1</sub>, see clause 6.

ISO 3314:1975

<https://standards.iteh.ai/catalog/standards/sist/1418c28f-a2ff-4ec3-b6ea-8011b01614b/iso-3314-1975>

5 INTERCHANGEABILITY DIMENSIONS OF SLOTS

*z* = maximum permissible deviation between the axial plane of the slot and the axis of diameter *d*<sub>1</sub>.

TABLE 2

Dimensions in millimetres

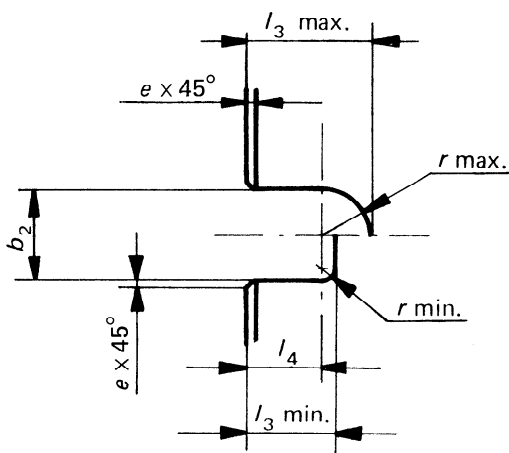

<i>d</i> <sub>1</sub> *	<i>b</i> <sub>2</sub> ** H13	<i>l</i> <sub>3</sub>		<i>r</i>		<i>l</i> <sub>4</sub>	<i>z</i> max.	<i>e</i> ***	
		min.	max.	min.	max.				
13	4,3	5,4	7,0	0,6	2,15	4,8	0,075	0,3	+ 0,1 0
16	5,4	6,2	8,3	0,6	2,70	5,6		0,4	
19	6,4	7,8	10,2	0,8	3,20	7,0		0,5	
22	7,4	8,6	11,3	1,0	3,70	7,6	0,100		+ 0,2 0
27	8,4	9,3	12,5	1,0	4,20	8,3		0,6	
32	10,4	10,5	14,5	1,2	5,20	9,3		0,8	
40	12,4	11,2	16,2	1,2	6,20	10,0			

\* For description of *d*<sub>1</sub>, see clause 6.

\*\* The width *b*<sub>2</sub> of the slot must always be parallel for the length *l*<sub>4</sub>.

\*\*\* Chamfers can be replaced by radii of the same value and tolerance.

6 METHOD OF CHECKING TAPER BORE

Tolerance on diameter  $d_1$  of the taper bore in the shell drill

The tolerance is determined by the amount of the permissible variation  $a_1$  in the position of the gauge plane of the taper bore. The value  $a_1$  represents the depth to which a taper plug gauge of the appropriate nominal size may enter the drills to be checked with respect to its gauge line.

The method of checking the arbor is shown in ISO 2402.

Lower permissible limit

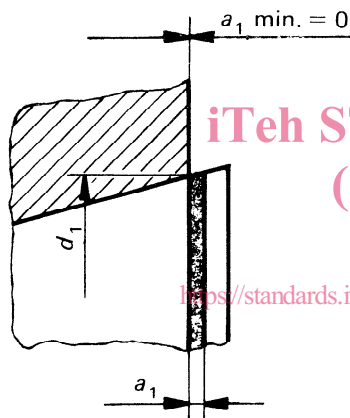

Taper plug gauge

Upper permissible limit

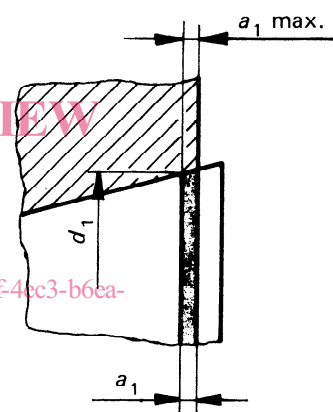

Taper plug gauge

iTeh STANDARD PREVIEW  
(standards.iteh.ai)

ISO 3314:1975

<https://standards.iteh.ai/catalog/standards/sist/1418c28f-a2ff-4ec3-b6ca-8011b01614b/iso-3314-1975>

TABLE 3

Dimensions in millimetres

$d_1$	$a_1$	
	min.	max.
13	0	0,6
16		
19		
22	0	0,7
27		
32	0	0,9
40		

ANNEX

**A.1 RECOMMENDED STOCKED SIZES OF SHELL DRILLS**

The following diameters of shell drills are recommended as stocked sizes :

25 – 26 – 27 – 28 – 29 – 30 – 31 – 32 – 33 – 34 – 35 – 36 – 37 – 38 – 39 – 40 – 42 – 44 – 45 – 46 – 47 – 48 – 50 – 52 – 55 – 58 – 60 – 62 – 65 – 70 – 72 – 75 – 80 – 85 – 90 – 95 – 100 mm.

**A.2 EXTRACT FROM ISO 2402 – DIMENSIONS OF ARBORS FOR SHELL DRILLS WITH TAPER FITMENT (TAPER 1 : 30 (INCLUDED)) WITH TENON DRIVE**

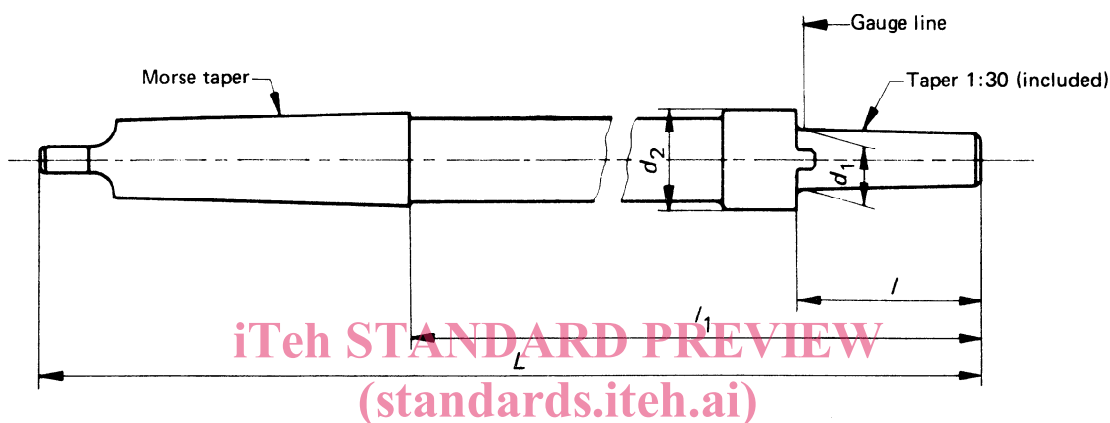

iTeh STANDARD PREVIEW  
(standards.iteh.ai)

ISO 3314:1975

Ranges of shell drill outside diameters $d$		$d_1$	Morse taper shank No.	$d_2$ max.	$l$ h16	$l_1$	$L$
above	up to and including						
23,6	35,5	13	3	21	45	151	250
35,5	45	16	3	27	50	162	261
45	53	19	4	32	56	174	298
53	63	22	4	39	63	188	312
63	75	27	5	46	71	203	359
75	90	32	5	56	80	220	376
90	101,6	40	5	65	90	240	396

**iTeh STANDARD PREVIEW**  
**(standards.iteh.ai)**

This page intentionally left blank

[ISO 3314:1975](#)

<https://standards.iteh.ai/catalog/standards/sist/1418c28f-a2ff-4ec3-b6ea-8011bf01614b/iso-3314-1975>

**iTeh STANDARD PREVIEW**  
**(standards.iteh.ai)**

This page intentionally left blank

[ISO 3314:1975](#)

<https://standards.iteh.ai/catalog/standards/sist/1418c28f-a2ff-4ec3-b6ea-8011bf01614b/iso-3314-1975>