



Standard Specification for Metal Insert Fittings Utilizing a Copper Crimp Ring for SDR9 Cross-linked Polyethylene (PEX) Tubing and SDR9 Polyethylene of Raised Temperature (PE-RT) Tubing¹

This standard is issued under the fixed designation F1807; the number immediately following the designation indicates the year of original adoption or, in the case of revision, the year of last revision. A number in parentheses indicates the year of last reapproval. A superscript epsilon (ϵ) indicates an editorial change since the last revision or reapproval.

1. Scope*

1.1 This specification covers metal insert fittings and copper crimp rings for use with cross-linked polyethylene (PEX) tubing in $\frac{3}{8}$, $\frac{1}{2}$, $\frac{5}{8}$, $\frac{3}{4}$, 1, 1 $\frac{1}{4}$, 1 $\frac{1}{2}$, and 2 in. nominal diameters that meet the requirements for Specifications F876 and F877 and for use with polyethylene of raised temperature (PE-RT) tubing in $\frac{3}{8}$, $\frac{1}{2}$, $\frac{5}{8}$, $\frac{3}{4}$ and 1 in. and 1 $\frac{1}{4}$ in. nominal diameters that meet the requirements of Specifications F2623 and F2769. These fittings are intended for use in 100 psi (689.5 kPa) cold- and hot-water distribution systems operating at temperatures up to, and including, 180°F (82°C). The requirements for materials, workmanship, dimensions, and markings to be used on the fittings and rings are also included.

1.2 The values stated in inch-pound units are to be regarded as the standard. The values given in parentheses are mathematical conversions to SI units which are provided for information only and are not considered the standard.

1.3 Compliance with this specification requires that these fittings be tested and certified to Specification F877 when used with PEX tubing and Specification F2769 when used with PE-RT tubing.

1.4 *This standard does not purport to address all of the safety concerns, if any, associated with its use. It is the responsibility of the user of this standard to establish appropriate safety and health practices and determine the applicability of regulatory limitations prior to use.*

2. Referenced Documents

2.1 ASTM Standards:²

¹ This standard is under the jurisdiction of ASTM Committee F17 on Plastic Piping Systems and is the direct responsibility of Subcommittee F17.10 on Fittings.

Current edition approved Aug. 15, 2013. Published September 2013. Originally approved in 1997. Last previous edition approved in 2013 as F1807 – 13. DOI: 10.1520/F1807-13A.

² For referenced ASTM standards, visit the ASTM website, www.astm.org, or contact ASTM Customer Service at service@astm.org. For *Annual Book of ASTM Standards* volume information, refer to the standard's Document Summary page on the ASTM website.

- A269 Specification for Seamless and Welded Austenitic Stainless Steel Tubing for General Service
- A276 Specification for Stainless Steel Bars and Shapes
- A312/A312M Specification for Seamless, Welded, and Heavily Cold Worked Austenitic Stainless Steel Pipes
- B16/B16M Specification for Free-Cutting Brass Rod, Bar and Shapes for Use in Screw Machines
- B62 Specification for Composition Bronze or Ounce Metal Castings
- B75 Specification for Seamless Copper Tube
- B88 Specification for Seamless Copper Water Tube
- B124/B124M Specification for Copper and Copper Alloy Forging Rod, Bar, and Shapes
- B140/B140M Specification for Copper-Zinc-Lead (Red Brass or Hardware Bronze) Rod, Bar, and Shapes
- B283 Specification for Copper and Copper-Alloy Die Forgings (Hot-Pressed)
- B371/B371M Specification for Copper-Zinc-Silicon Alloy Rod
- B584 Specification for Copper Alloy Sand Castings for General Applications
- B967/B967M Specification for Copper-Zinc-Tin-Bismuth Alloy Rod, Bar and Wire
- D1600 Terminology for Abbreviated Terms Relating to Plastics
- D2122 Test Method for Determining Dimensions of Thermoplastic Pipe and Fittings
- E18 Test Methods for Rockwell Hardness of Metallic Materials
- F412 Terminology Relating to Plastic Piping Systems
- F876 Specification for Crosslinked Polyethylene (PEX) Tubing
- F877 Specification for Crosslinked Polyethylene (PEX) Hot- and Cold-Water Distribution Systems
- F2623 Specification for Polyethylene of Raised Temperature (PE-RT) SDR 9 Tubing
- F2769 Specification for Polyethylene of Raised Temperature (PE-RT) Plastic Hot and Cold-Water Tubing and Distribution Systems

*A Summary of Changes section appears at the end of this standard

2.2 ASME Standards:³

B1.20.1 Pipe Threads General Purpose (Inch)

B16.18 Cast Copper Alloy Solder Joint Pressure Fittings

B16.22 Wrought Copper and Copper Alloy Solder Joint Pressure Fittings

2.3 Manufacturer's Standardization Society Standard:⁴

SP-104 Wrought Copper Solder Joint Pressure Fittings

2.4 NSF International Standard:⁵

Standard No. 14 for Plastic Piping Components and Related Materials

Standard No. 61 for Drinking Water System Components-Health Effects

2.5 EN Standards⁶

EN 12164 Copper and Copper Alloys-Rod for Free Machining Purposes

EN 12165 Copper and Copper Alloys-Wrought and Unwrought Forging Stock

EN 1982 Copper and Copper Alloys, Ingots and Castings

Specification **B371/B371M** Copper Alloy UNS No. C69300, or Standard EN 12164, Copper Alloy CW614N, or Copper Alloy UNS No. C27450, or Specification **B967/B967M** copper alloy UNS No. C49260 or C49340.

5.1.4 *Forged Brass*—Forged brass fittings shall be made from material meeting the requirements of Specification **B283**, Copper Alloy UNS Nos. C27450, C35330, C36500, C37700, C46400, C48600, C49260, C49340, C69300 or C87700.

5.1.5 *Stainless Steel*—Stainless steel fittings shall be made from material meeting requirements of Specification **A312/A312M**, stainless steel alloy 304, 304L, 316 or 316L, (UNS Nos. S30400, S30403, S31600 or S31603), or Specification **A269**, stainless steel alloy 304, 304L, 316, 316L (UNS Nos. S30400, S30403, S31600 or S31603), or Specification **A276**, Stainless steel alloy 304, 401L, 316, or 316L (UNS Nos. S30400, S30403, S31600 or S31603)

5.2 *Crimp Rings*—Crimp rings shall be made from copper UNS Nos. C10200 or C12200, and shall be black in color. The crimp rings shall have a minimum allowable hardness of 35 and a maximum allowable hardness of 45 on the Rockwell 15T scale when measured according to Test Methods **E18**.

6. General Requirements

6.1 When fittings manufactured according to this specification are intended for use with the PEX tubing, the following sections of Specification **F877** constitute a part of this specification.

6.1.1 Requirements,

6.1.2 Test Methods, and

6.1.3 Retest and Rejection.

6.2 In addition, when a section with a title identical to that referenced in **6.1** appears in this specification, it contains additional requirements that supplement those appearing in Specification **F877**.

6.3 When fittings manufactured according to this specification are intended for use with PE-RT tubing, the following sections of Specification **F2769** constitute a part of this specification:

6.3.1 Requirements,

6.3.2 Test Methods, and

6.3.3 Retest and Rejection.

6.4 In addition, when a section with a title identical to that referenced in **6.3** appears in this specification, it contains additional requirements that supplement those appearing in Specification **F2769**.

6.5 *Dimensions*—Any randomly selected fitting or fittings, and crimp ring or crimp rings, shall be used to determine dimensions. Measurements shall be made in accordance with Test Method **D2122**, except when determining diameters, which is done by making measurements at four locations spaced approximately 45° apart around the circumference. Inspection and gauging of solder joint ends shall be in accordance with ASME B16.18, ASME B16.22, or MSS SP-104.

6.6 *General*—All performance tests shall be performed on assemblies of fittings, crimp rings, and PEX tubing or PE-RT

3. Terminology

3.1 Definitions are in accordance with Terminology **F412** and abbreviations are in accordance with Terminology **D1600**, unless otherwise indicated.

4. Classification

4.1 This specification covers one class of fittings and copper crimp rings suitable for use with PEX tubing that meet the requirements of Specifications **F876** or **F877** or with PE-RT tubing that meet the requirements of Specifications **F2623** and **F2769** or a combination thereof.

5. Materials and Manufacture

5.1 *Fittings*—The fittings shall be made from one of the following metals:

5.1.1 *Wrought Copper*—Wrought copper fittings shall be made from material meeting the requirements of Specification **B75** or **B88** for one of the following coppers: copper UNS Nos. C10200, C10300, C10800, or C12200.

5.1.2 *Cast Copper Alloys*—Cast copper alloy fittings shall be made from material meeting the requirements of Specification **B584**, copper alloy UNS Nos. C84400, C83800, C87710, C87850 or C89844 or Specification **B62**, copper alloy UNS No. C83600, or Standard EN 1982, copper alloy EN Symbol CuSn4Zn6Pb3-C.

5.1.3 *Machined Brass*—Machined brass fittings shall be made from material meeting the requirements of Specification **B140/B140M** copper alloy UNS No. C31400, or Specification **B16/B16M**, Copper Alloy UNS No. C36000, Specification **B124/B124M** copper alloy UNS No. C48600, or C87700, or

³ Available from American Society of Mechanical Engineers (ASME), ASME International Headquarters, Three Park Ave., New York, NY 10016-5900, <http://www.asme.org>.

⁴ Available from Manufacturers Standardization Society of the Valve and Fittings Industry (MSS), 127 Park St., NE, Vienna, VA 22180-4602, <http://www.msshq.com>.

⁵ Available from NSF International, P.O. Box 130140, 789 N. Dixboro Rd., Ann Arbor, MI 48113-0140, <http://www.nsf.org>.

⁶ Available from European Committee for Standardization (CEN), 36 rue de Stassart, B-1050, Brussels, Belgium, <http://www.cenorm.be>.

tubing. Fittings and crimp rings shall meet the material and dimensional requirements of this specification. PEX tubing shall meet the requirements of Specifications F876 or F877. PE-RT tubing shall meet the requirements of Specification F2769. Assembly of test specimens shall be in accordance with 9.1.1. Use separate sets of assemblies for each performance test requirement.

7. Dimensions

7.1 Dimensions and Tolerances—The dimensions and tolerances of fittings and crimp rings shall be as shown in Fig. 1,

Fig. 2, Fig. 3, and Fig. 4, when measured in accordance with 6.5.

7.1.1 Alignment—The maximum angular variation of any opening shall not exceed 1° off the true centerline axis.

7.1.2 Fittings with Solder Joint Ends—Solder joint ends shall be in accordance with ASME B16.22, ASME B16.18, or MSS SP-104.

7.1.3 Tapered Threaded Ends—Fitting threads shall be right-hand conforming to ASME B1.20.1. They shall be taper threads (NPT).

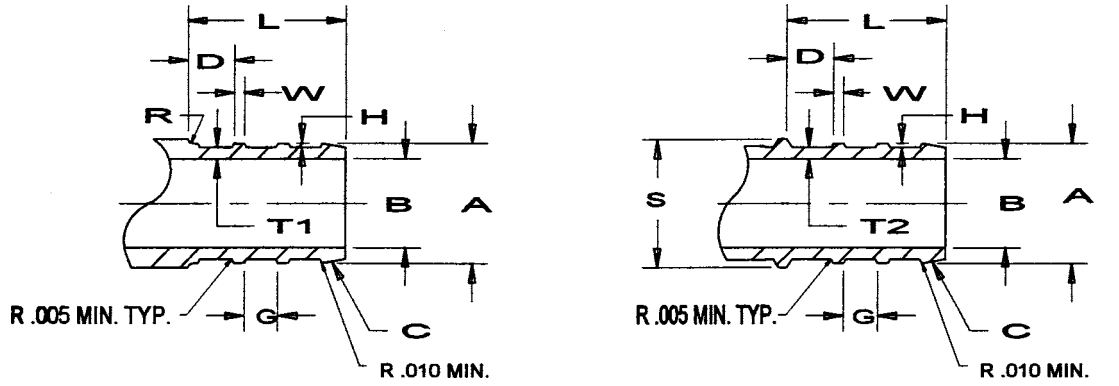

INSERT FOR BRASS, STAINLESS STEEL OR COPPER ALLOY FITTINGS

INSERT FOR WROUGHT COPPER FITTINGS

C
ENTRANCE
CHAMFER
10 - 30 deg.

standards (https://standards.iteh.ai) Document Preview

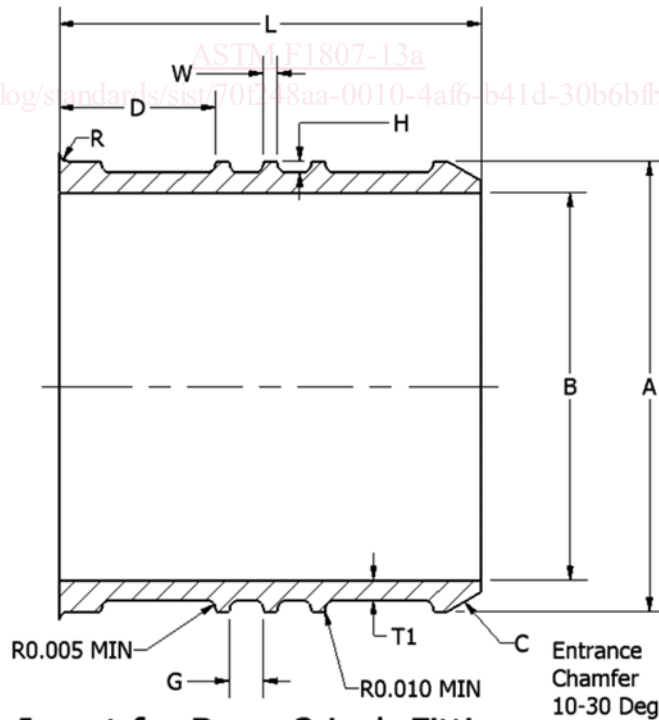

Insert for Brass 2 inch Fittings

FIG. 1 Fitting Insert Dimensions and Tolerances

Size	A Outside Diameter of Rib ^A	B Minimum ID	D Distance to First Rib ^B	L Minimum Insert Length ^A	H Minimum Rib Height	Number of Ribs ^C	W Rib ^D Width	G Rib Spacing Typical	T1 Minimum Wall ^E	T2 Minimum Wall ^E	R Minimum Radius	S Minimum Average Diam- eter ^F	Maximum Flash and Mismatch, Total on Crest Diameter ^{G,H}
3/8 in.	0.345 ± 0.004	0.230	0.180–0.224	0.625	0.013	2	0.03–0.05	0.120–0.145	0.025	0.025	0.02	0.369	0.005
1/2 in.	0.471 ± 0.004	0.350	0.180–0.224	0.625	0.013	2	0.03–0.05	0.120–0.145	0.028	0.028	0.02	0.495	0.005
5/8 in.	0.570 ± 0.004	0.451	0.180–0.224	0.625	0.013	2	0.03–0.05	0.120–0.145	0.032	0.032	0.02	0.595	0.005
3/4 in.	0.667 ± 0.004	0.530	0.180–0.224	0.625	0.013	2	0.03–0.05	0.120–0.145	0.037	0.032	0.02	0.691	0.005
1 in.	0.856 ± 0.004	0.710	0.180–0.224	0.795	0.015	3	0.03–0.05	0.120–0.145	0.041	0.035	0.02	0.880	0.005
1 1/4 in.	1.045 ± 0.004	0.870	0.130 Min	0.940	0.020	3 Min	0.03–0.05	0.120–0.145	0.045	0.041	0.02	1.069	0.005
1 1/2 in.	1.233 ± 0.006	1.020	0.130 Min	1.145	0.025	3 Min	0.030–0.050	0.120–0.180	0.053	...	0.020	...	0.005
2 in.	1.602 ± 0.005	1.365	0.130 Min	1.500	0.035	3 Min	0.030–0.070	0.120–0.180	0.071	...	0.020	...	0.005

^A Measured from shoulder of rib to tube stop.
^B Fitting shall be designed with sufficient overall dimensions to allow proper use of crimp tool without interference with previously completed crimps on the same fitting.
^C Lead chamfer area is not considered a rib.
^D Rib sides may be angled.
^E Applies to entire fitting, not just insert area.
^F The raised area serves as a tube stop for wrought copper fittings that do not have a shoulder.
^G The maximum flash and mismatch at the root diameter between the ribs may not exceed 30 % of the rib height.
^H The total flash and mismatch is assumed to be the difference between the dimensions X and Y (see Fig. 2). These dimensions may be measured with appropriate calipers or micrometers. See Fig. 3 for a graphic definition of flash and mismatch created by imperfection in die half interfaces.

FIG. 1 Fitting Insert Dimensions and Tolerances (continued)

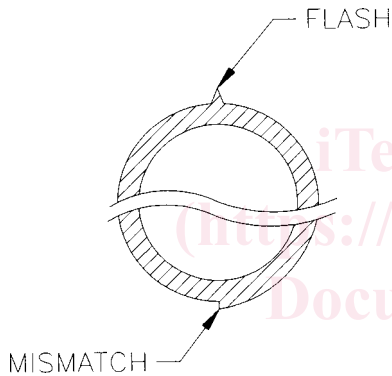

FIG. 2 Flash and Mismatch Created by Imperfection in Die Half Interfaces

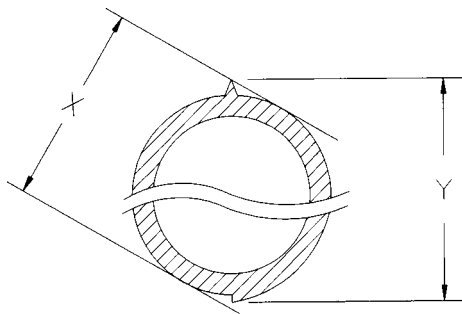

FIG. 3 Total Flash and Mismatch

ring around the outer circumference of the tubing, forcing the tubing material into annular spaces formed by ribs on the fitting. Insert fittings and crimp rings shall meet the dimensional and material requirements of this standard. PEX tubing shall meet the requirements of Specifications F876 or F877. PE-RT tubing shall meet the requirements of Specification F2769. The dimensions and out-of-roundness of the crimp ring, after it has been crimped, shall be in accordance with Table 1.

9.1.1 *Crimping Procedure*—The crimping procedure shall be as follows: slide the crimp ring onto the tubing, insert the ribbed end of the fitting into the end of the tubing until the tubing contacts the shoulder of the fitting or tube stop. For fitting sizes 3/8 to 1 1/4 in. the crimp ring shall then be positioned on the tubing so the edge of the crimp ring is 1/8 to 1/4 in. (3.2 to 6.4 mm) from the end of the tube. For 1 1/2 in. fitting size the crimp ring shall be positioned 1/4 to 3/8 in. (6.4 to 9.5 mm) from the end of tube. For 2 in. fitting size the crimp ring shall be positioned 3/8 to 1/2 in. (9.5 to 12.7 mm) from the end of the tube. The jaws of the crimping tool shall be centered over the crimp ring and the tool shall be held so that the crimping jaws are approximately perpendicular to the axis of the barb. The jaws of the crimping tool shall be closed around the crimp ring, compressing the crimp ring onto the tubing. The crimp ring shall not be crimped more than once. Each crimp shall be checked to determine conformance to the after-crimped dimensional requirements of Table 1.

8. Workmanship, Finish, and Appearance

8.1 The sealing surfaces of the insert shall be smooth and free of foreign material. Fitting walls shall be free of cracks, holes, blisters, voids, foreign inclusions, or other defects that are visible to the unaided eye and affect the wall integrity.

9. Assembly

9.1 *Crimp Joints*—Insert fittings shall be joined to PEX tubing or PE-RT tubing by the compression of a copper crimp

10. Product Marking

10.1 *Quality of Marking*—The marking shall be applied to the fittings in such a manner that it remains legible after installation and inspection.

10.2 Content of Marking:

10.2.1 Marking on fittings shall include manufacturer's name or trademark, or some other identifying mark, and if size permits, PEX/PE-RT or the ASTM standard number, or a combination thereof.