

ISO/TC 61/SC 12

Secretariat: JISC

Voting begins on:
2023-07-04

Voting terminates on:
2023-08-29

Plastics — Determination of apparent density of moulding material that cannot be poured from a specified funnel

Plastiques — Détermination de la masse volumique apparente des matières à mouler non susceptibles de s'écouler à travers un entonnoir donné

iTeh STANDARD PREVIEW
(standards.iteh.ai)

ISO 61

<https://standards.iteh.ai/catalog/standards/sist/993ac159-a0b5-48bb-be3a-cff22b7c13cd/iso-61>

ISO/CEN PARALLEL PROCESSING

RECIPIENTS OF THIS DRAFT ARE INVITED TO SUBMIT, WITH THEIR COMMENTS, NOTIFICATION OF ANY RELEVANT PATENT RIGHTS OF WHICH THEY ARE AWARE AND TO PROVIDE SUPPORTING DOCUMENTATION.

IN ADDITION TO THEIR EVALUATION AS BEING ACCEPTABLE FOR INDUSTRIAL, TECHNOLOGICAL, COMMERCIAL AND USER PURPOSES, DRAFT INTERNATIONAL STANDARDS MAY ON OCCASION HAVE TO BE CONSIDERED IN THE LIGHT OF THEIR POTENTIAL TO BECOME STANDARDS TO WHICH REFERENCE MAY BE MADE IN NATIONAL REGULATIONS.



Reference number
ISO/FDIS 61:2023(E)

© ISO 2023

iTeh STANDARD PREVIEW
(standards.iteh.ai)

ISO 61

<https://standards.iteh.ai/catalog/standards/sist/993ac159-a0b5-48bb-be3a-cff22b7c13cd/iso-61>



COPYRIGHT PROTECTED DOCUMENT

© ISO 2023

All rights reserved. Unless otherwise specified, or required in the context of its implementation, no part of this publication may be reproduced or utilized otherwise in any form or by any means, electronic or mechanical, including photocopying, or posting on the internet or an intranet, without prior written permission. Permission can be requested from either ISO at the address below or ISO's member body in the country of the requester.

ISO copyright office
CP 401 • Ch. de Blandonnet 8
CH-1214 Vernier, Geneva
Phone: +41 22 749 01 11
Email: copyright@iso.org
Website: www.iso.org

Published in Switzerland

Contents

	Page
Foreword.....	iv
Introduction.....	v
1 Scope.....	1
2 Normative references.....	1
3 Terms and definitions.....	1
4 Apparatus.....	1
5 Procedure.....	2
6 Expression of results.....	3
7 Test report.....	3
Bibliography.....	4

iTeh STANDARD PREVIEW (standards.iteh.ai)

<https://standards.iteh.ai/catalog/standards/sist/993ac159-a0b5-48bb-be3a-cff22b7c13cd/iso-61>

Foreword

ISO (the International Organization for Standardization) is a worldwide federation of national standards bodies (ISO member bodies). The work of preparing International Standards is normally carried out through ISO technical committees. Each member body interested in a subject for which a technical committee has been established has the right to be represented on that committee. International organizations, governmental and non-governmental, in liaison with ISO, also take part in the work. ISO collaborates closely with the International Electrotechnical Commission (IEC) on all matters of electrotechnical standardization.

The procedures used to develop this document and those intended for its further maintenance are described in the ISO/IEC Directives, Part 1. In particular, the different approval criteria needed for the different types of ISO document should be noted. This document was drafted in accordance with the editorial rules of the ISO/IEC Directives, Part 2 (see www.iso.org/directives).

ISO draws attention to the possibility that the implementation of this document may involve the use of (a) patent(s). ISO takes no position concerning the evidence, validity or applicability of any claimed patent rights in respect thereof. As of the date of publication of this document, ISO had not received notice of (a) patent(s) which may be required to implement this document. However, implementers are cautioned that this may not represent the latest information, which may be obtained from the patent database available at www.iso.org/patents. ISO shall not be held responsible for identifying any or all such patent rights.

Any trade name used in this document is information given for the convenience of users and does not constitute an endorsement.

For an explanation of the voluntary nature of standards, the meaning of ISO specific terms and expressions related to conformity assessment, as well as information about ISO's adherence to the World Trade Organization (WTO) principles in the Technical Barriers to Trade (TBT), see www.iso.org/iso/foreword.html.

This document was prepared by Technical Committee ISO/TC 61, *Plastics*, Subcommittee SC 12, *Thermosetting materials*, in collaboration with the European Committee for Standardization (CEN) Technical Committee CEN/TC 249, *Plastics*, in accordance with the Agreement on technical cooperation between ISO and CEN (Vienna Agreement).

This second edition cancels and replaces the first edition (ISO 61:1976), which has been technically revised.

The main changes are as follows:

- specified the loose moulding material;
- added the mandatory [Clause 2](#) (Normative reference) and renumbered the subsequent clauses;
- added the mandatory [Clause 3](#) (Terms and definitions) and renumbered the subsequent clauses;
- added a “Ruler” in the list of apparatus;
- added [Figure 1](#) in apparatus;
- added the requirement “Tested samples shall not be reused” in procedure;
- added the requirement “Take two significant digits” in expression of results;
- added information to be included in the test report, i.e. “a reference to this document”, “standard deviation, and/or coefficient of variation, and/or confidence limits of mean, if required”, “any other observations”, “date of test”.

Any feedback or questions on this document should be directed to the user's national standards body. A complete listing of these bodies can be found at www.iso.org/members.html.

Introduction

Apparent density refers to the ratio of mass to apparent volume of a material in its natural state (dry state stored in air for a long time).

A knowledge of apparent density is of limited value in estimating the relative fluffiness or bulk of moulding materials, unless their densities in the moulded condition are approximately the same.

iTeh STANDARD PREVIEW
(standards.iteh.ai)

<https://standards.iteh.ai/catalog/standards/sist/993ac159-a0b5-48bb-be3a-cff22b7c13cd/iso-61>

Plastics — Determination of apparent density of moulding material that cannot be poured from a specified funnel

1 Scope

This document specifies a method of determining the apparent density, i.e. the mass per unit of volume, of loose material that cannot be poured from a funnel of specified design.

NOTE For a method of determining the apparent density of loose moulding material that can be poured from a specified funnel, see ISO 60.

This document is applicable to loose moulding materials such as slice, granular or powder.

2 Normative references

There are no normative references in this document.

3 Terms and definitions

No terms and definitions are listed in this document.

ISO and IEC maintain terminology databases for use in standardization at the following addresses:

- ISO Online browsing platform: available at <https://www.iso.org/obp>
- IEC Electropedia: available at <https://www.electropedia.org/>

4 Apparatus

4.1 Balance, accurate to 0,1 g.

4.2 Ruler, accurate to 1 mm.

4.3 Measuring cylinder, smoothly finished inside, which may be constructed of metal, of capacity of $(1\ 000 \pm 20)$ ml, and internal diameter (90 ± 2) mm (see [Figure 1](#)).

4.4 Plunger, consisting of a hollow cylinder of mass $(2\ 300 \pm 20)$ g, close at one end and having an external diameter slightly smaller than the internal diameter of the measuring cylinder. The plunger may conveniently be weighted with lead shot (see [Figure 1](#)).

Dimensions in millimetres

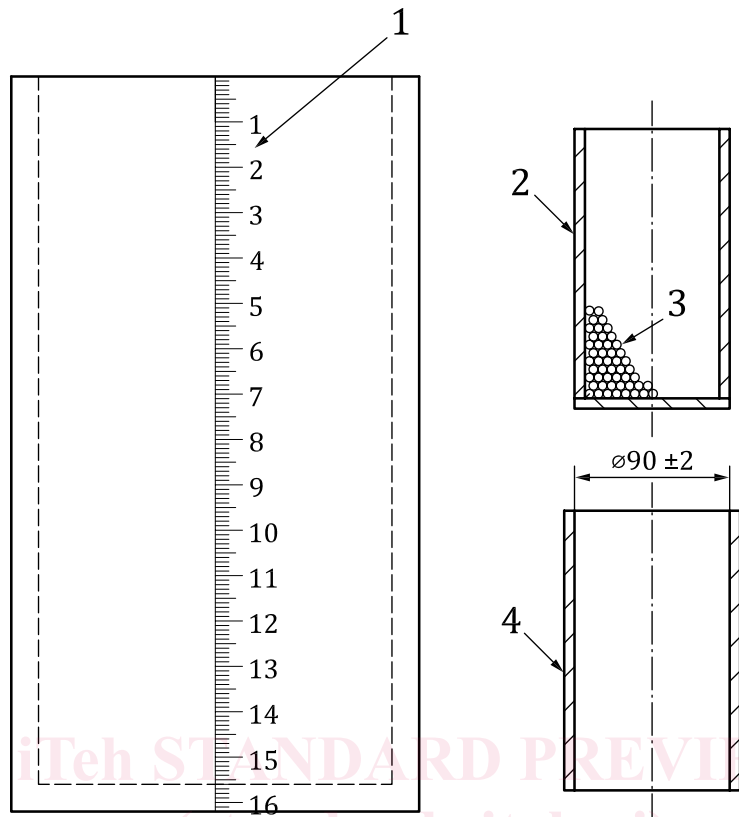

Key

- 1 scale
- 2 plunger
- 3 lead block or material that can make the piston reach the required quality
- 4 measuring cylinder

NOTE The capacity of measuring cylinder is 1 000 ml \pm 20 ml.

Figure 1 — Schematic diagram of apparent density test instrument

5 Procedure

5.1 Drop $(60 \pm 0,2)$ g of loose moulding material, little by little, into the measuring cylinder (4.3) so that it is distributed evenly with its surface as level as possible. Lower the plunger (4.4) slowly into the measuring cylinder until it is entirely supported by the material. After 1 min, measure the height of the material, with the plunger resting upon it, to the nearest 1 mm. A convenient method of measuring the height of the material is, for example, by means of a suitable scale marked vertically on the outside surface of the plunger.

5.2 Make three determinations on the sample of moulding material under test. Test samples shall not be reused.

NOTE When the method is applied to relatively coarse materials, rather variable results may be obtained, owing to the error introduced when a straightedge blade is drawn across the top of the cylinder.

6 Expression of results

The apparent density, d , of the moulding material under test is given, in grams per millilitre (see NOTE), by [Formula \(1\)](#)

$$d = \frac{m}{A \times h} \quad (1)$$

where

d is the apparent density;

m is the mass, in grams, of the material placed in the measuring cylinder;

A is the internal cross-sectional area of the measuring cylinder, in square centimetres;

h is the height of moulding materials in the measuring cylinder, in centimetres.

NOTE Although apparent density is calculated in grams per cubic centimetre, it is expressed here in grams per millilitre for the sake of uniformity with ISO 60. No adjustment of the test result is required.

Take, as the result, the arithmetic mean of the results of the three determinations. Take two significant digits.

7 Test report

The test report shall include the following information:

- a) a reference to this document, i.e. ISO 61:2023;
- b) complete identification of the material tested;¹
- c) the individual results and mean;
- d) standard deviation, and/or coefficient of variation, and/or confidence limits of mean, if required;
- e) any other observations;
- f) date of test.

Bibliography

- [1] ISO 60, *Plastics — Determination of apparent density of material that can be poured from a specified funnel*

iTeh STANDARD PREVIEW
(standards.iteh.ai)

<https://standards.iteh.ai/catalog/standards/sist/993ac159-a0b5-48bb-be3a-cff22b7c13cd/iso-61>