

FINAL
DRAFT

INTERNATIONAL
STANDARD

ISO/FDIS
407

ISO/TC 58/SC 2

Secretariat: AFNOR

Voting begins on:
2023-03-08

Voting terminates on:
2023-05-31

Small medical gas cylinders — Pin-index yoke-type valve connections

Petites bouteilles à gaz médicaux — Raccords de robinets du type étrier avec ergots de sécurité

iTeh STANDARD PREVIEW
(standards.iteh.ai)

ISO/FDIS 407

<https://standards.iteh.ai/catalog/standards/sist/dc3974ad-f252-4d14-a2d2-d495f7fa7d77/iso-fdis-407>

ISO/CEN PARALLEL PROCESSING

RECIPIENTS OF THIS DRAFT ARE INVITED TO SUBMIT, WITH THEIR COMMENTS, NOTIFICATION OF ANY RELEVANT PATENT RIGHTS OF WHICH THEY ARE AWARE AND TO PROVIDE SUPPORTING DOCUMENTATION.

IN ADDITION TO THEIR EVALUATION AS BEING ACCEPTABLE FOR INDUSTRIAL, TECHNOLOGICAL, COMMERCIAL AND USER PURPOSES, DRAFT INTERNATIONAL STANDARDS MAY ON OCCASION HAVE TO BE CONSIDERED IN THE LIGHT OF THEIR POTENTIAL TO BECOME STANDARDS TO WHICH REFERENCE MAY BE MADE IN NATIONAL REGULATIONS.



Reference number
ISO/FDIS 407:2023(E)

© ISO 2023

iTeh STANDARD PREVIEW
(standards.iteh.ai)

ISO/FDIS 407

<https://standards.iteh.ai/catalog/standards/sist/dc3974ad-f252-4d14-a2d2-d495f7fa7d77/iso-fdis-407>



COPYRIGHT PROTECTED DOCUMENT

© ISO 2023

All rights reserved. Unless otherwise specified, or required in the context of its implementation, no part of this publication may be reproduced or utilized otherwise in any form or by any means, electronic or mechanical, including photocopying, or posting on the internet or an intranet, without prior written permission. Permission can be requested from either ISO at the address below or ISO's member body in the country of the requester.

ISO copyright office
CP 401 • Ch. de Blandonnet 8
CH-1214 Vernier, Geneva
Phone: +41 22 749 01 11
Email: copyright@iso.org
Website: www.iso.org

Published in Switzerland

Contents

Page

Foreword.....	iv
1 Scope.....	1
2 Normative references.....	1
3 Terms and definitions.....	1
4 Valve.....	1
5 Yoke.....	2
6 Basic dimensions.....	2
6.1 General.....	2
6.2 Pin-index yoke-type valve body.....	3
6.3 Single-pin yoke-type valve connection system.....	4
6.4 Two-pin yoke-type valve connection system with the pins in a single row.....	4
6.5 Two-pin yoke-type valve connection system with the pins in a double row.....	5
6.6 Basic dimensions.....	5
7 Requirements for alternative designs of yoke-type valve connections.....	6
7.1 Requirements for the design of the connecting yoke.....	6
7.2 Examples of alternative construction for the connecting yoke.....	6
8 Dimensions and positions of the holes and pins for yoke-type valve connections.....	9
8.1 General.....	9
8.2 Outlet connection with single-pin system.....	9
8.3 Outlet connections with two-pin/single-row system.....	10
8.3.1 Outlet connection for oxygen.....	10
8.3.2 Outlet connection for oxygen/carbon dioxide mixture ($\text{CO}_2 \leq 7\%$).....	11
8.3.3 Outlet connection for oxygen/helium mixture ($\text{He} \leq 80\%$).....	11
8.3.4 Outlet connection for ethylene.....	12
8.3.5 Outlet connection for nitrous oxide (with or without liquid draw-off).....	12
8.3.6 Outlet connection for cyclopropane.....	13
8.3.7 Outlet connection for helium and for helium/oxygen mixture ($\text{O}_2 < 20\%$).....	13
8.3.8 Outlet connection for carbon dioxide (with or without liquid draw-off) and for carbon dioxide/oxygen mixture ($\text{CO}_2 > 7\%$).....	14
8.3.9 Outlet connection for medical air.....	14
8.3.10 Outlet connection for nitrogen.....	15
8.4 Outlet connection with two-pin/double-row system.....	15

Foreword

ISO (the International Organization for Standardization) is a worldwide federation of national standards bodies (ISO member bodies). The work of preparing International Standards is normally carried out through ISO technical committees. Each member body interested in a subject for which a technical committee has been established has the right to be represented on that committee. International organizations, governmental and non-governmental, in liaison with ISO, also take part in the work. ISO collaborates closely with the International Electrotechnical Commission (IEC) on all matters of electrotechnical standardization.

The procedures used to develop this document and those intended for its further maintenance are described in the ISO/IEC Directives, Part 1. In particular, the different approval criteria needed for the different types of ISO documents should be noted. This document was drafted in accordance with the editorial rules of the ISO/IEC Directives, Part 2 (see www.iso.org/directives).

Attention is drawn to the possibility that some of the elements of this document may be the subject of patent rights. ISO shall not be held responsible for identifying any or all such patent rights. Details of any patent rights identified during the development of the document will be in the Introduction and/or on the ISO list of patent declarations received (see www.iso.org/patents).

Any trade name used in this document is information given for the convenience of users and does not constitute an endorsement.

For an explanation of the voluntary nature of standards, the meaning of ISO specific terms and expressions related to conformity assessment, as well as information about ISO's adherence to the World Trade Organization (WTO) principles in the Technical Barriers to Trade (TBT), see www.iso.org/iso/foreword.html.

This document was prepared by Technical Committee ISO/TC 58, *Gas cylinders*, Subcommittee SC 2, *Cylinders fittings*, in collaboration with the European Committee for Standardization (CEN) Technical Committee CEN/TC 23, *Transportable gas cylinders*, in accordance with the Agreement on technical cooperation between ISO and CEN (Vienna Agreement).

This fifth edition cancels and replaces the fourth edition (ISO 407:2021) of which it constitutes a minor revision.

The main changes are as follows:

- correction of [Figure 1](#).

Any feedback or questions on this document should be directed to the user's national standards body. A complete listing of these bodies can be found at www.iso.org/members.html.

Small medical gas cylinders — Pin-index yoke-type valve connections

1 Scope

This document is applicable to pin-index yoke-type valve connections for medical gas cylinders, with a working pressure up to a maximum of 200 bar or test pressure up to a maximum of 300 bar, or both.

NOTE 1 This type of connection is primarily used for small cylinders (5 l or below).

NOTE 2 In this document the unit bar is used, due to its universal use in the field of technical gases. It should, however, be noted that bar is not an SI unit, and that the corresponding SI unit for pressure is Pa (1 bar = 10^5 Pa = 10^5 N/m²).

This document specifies:

- basic dimensions;
- requirements for alternative designs of the yoke-type valve connections;
- dimensions and positions for the holes and pins for the outlet connections.

It also specifies the dimensions and positions for the holes and pins for the outlet connections for gases and gas mixtures.

2 Normative references

[ISO/FDIS 407](#)

The following documents are referred to in the text in such a way that some or all of their content constitutes requirements of this document. For dated references, only the edition cited applies. For undated references, the latest edition of the referenced document (including any amendments) applies.

ISO 32, *Gas cylinders for medical use — Marking for identification of content*

3 Terms and definitions

No terms and definitions are listed in this document.

ISO and IEC maintain terminological databases for use in standardization at the following addresses:

- ISO Online browsing platform: available at <https://www.iso.org/obp>
- IEC Electropedia: available at <https://www.electropedia.org/>

4 Valve

Each small medical gas cylinder can be fitted with a yoke valve (see [Clause 6](#)). The yoke valve shall have location holes of the dimensions and in the positions indicated in [Clause 8](#) for the appropriate gas or gas mixture (see [Table 1](#)).

The name or chemical symbol of the gas or gas mixture shall be clearly and indelibly stamped on the valve.

Table 1 — Allocated gases and gas mixtures

Gas or gas mixture	Chemical symbol
oxygen	O ₂
oxygen/carbon dioxide (CO ₂ ≤ 7 %)	O ₂ + CO ₂
oxygen/helium (He ≤ 80 %)	O ₂ + He
ethylene	C ₂ H ₄
nitrous oxide (with or without liquid draw-off)	N ₂ O
cyclopropane	C ₃ H ₆
helium	He
helium/oxygen (O ₂ < 20 %)	
carbon dioxide (with or without liquid draw-off)	CO ₂
carbon dioxide/oxygen CO ₂ > 7 %	
medical air	Air
nominal mixture 50 % oxygen/50 % nitrous oxide (47,5 % < N ₂ O < 52,5 %)	O ₂ + N ₂ O
nitrogen	N ₂
mixture of air, helium and carbon monoxide (CO < 1 %)	Air + He + CO

5 Yoke

The connecting yoke shall conform to the requirements and dimensions given in [Clauses 6](#) and [7](#). The yoke shall be fitted with pins, the dimensions and the positions of which correspond to the holes in the valve as indicated in [Clause 8](#) for the appropriate gas or gas mixture.

The name or chemical symbol of the gas or gas mixture shall be clearly and indelibly stamped on the yoke. If an identification colour is used, it shall be in conformity with ISO 32.

Examples of the alternative designs for the connecting yoke are given in [7.2](#).

In [Figures 3](#) and [4](#), the circled numbers and letters are the pin-hole positions.

6 Basic dimensions

6.1 General

The basic dimensions for pin-index yoke-type valve connections are shown in [Figures 1](#) to [4](#) and are listed in [Table 2](#).

6.2 Pin-index yoke-type valve body

Dimensions in millimetres

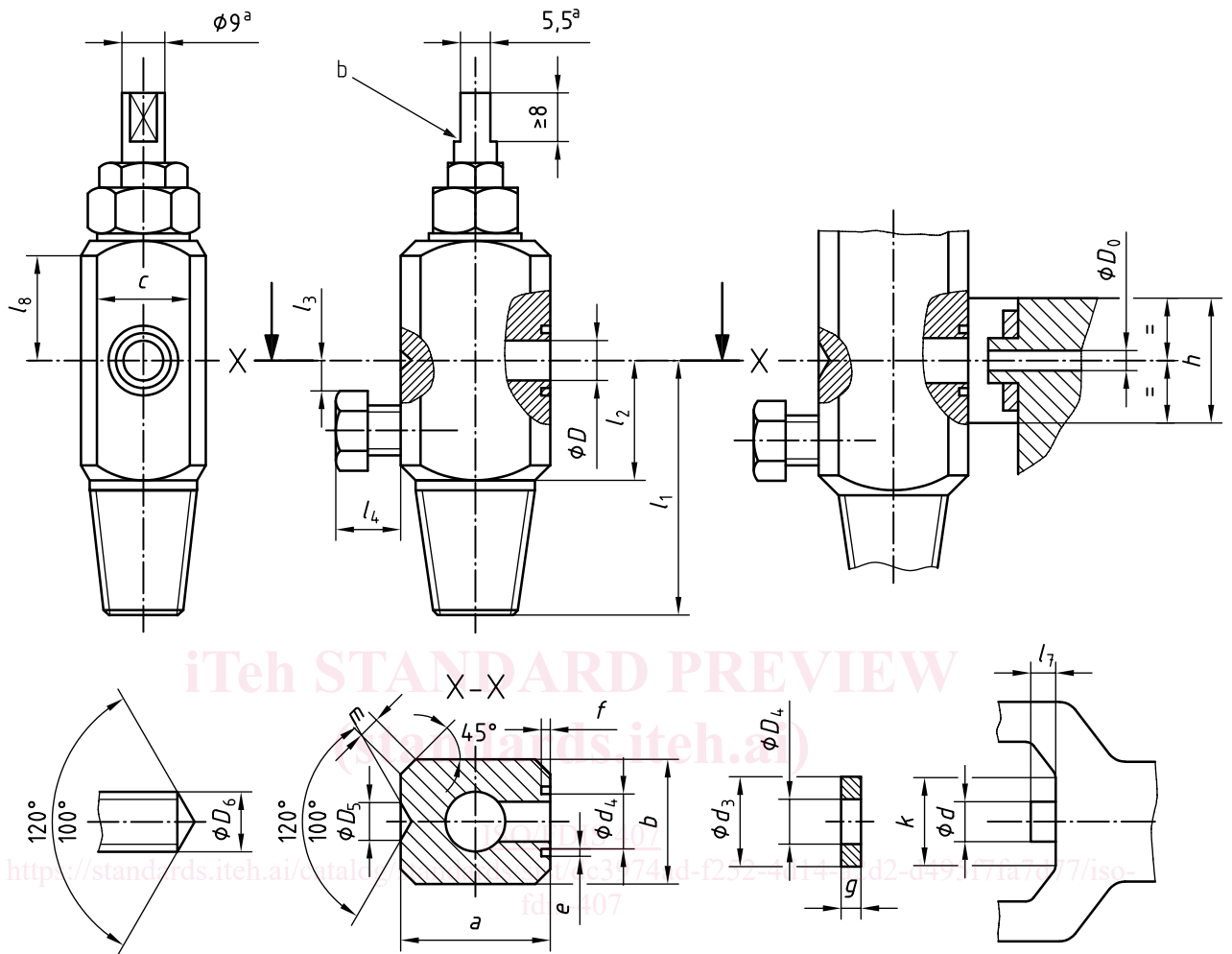

- a Applicable only to single-key valves.
- b Consider introduction of radius of 0,5 mm to avoid stress concentration.
- m Radius permitted, provided dimension c is maintained.

Figure 1 — Pin-index yoke-type valve body

6.3 Single-pin yoke-type valve connection system

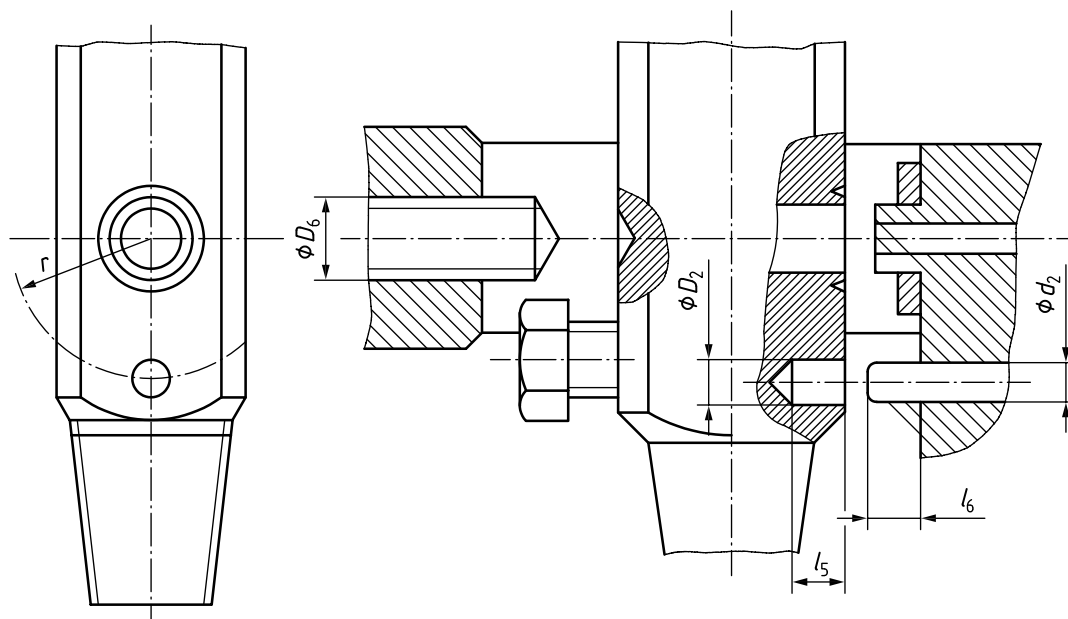

Figure 2 — Single-pin yoke-type valve connection system

6.4 Two-pin yoke-type valve connection system with the pins in a single row

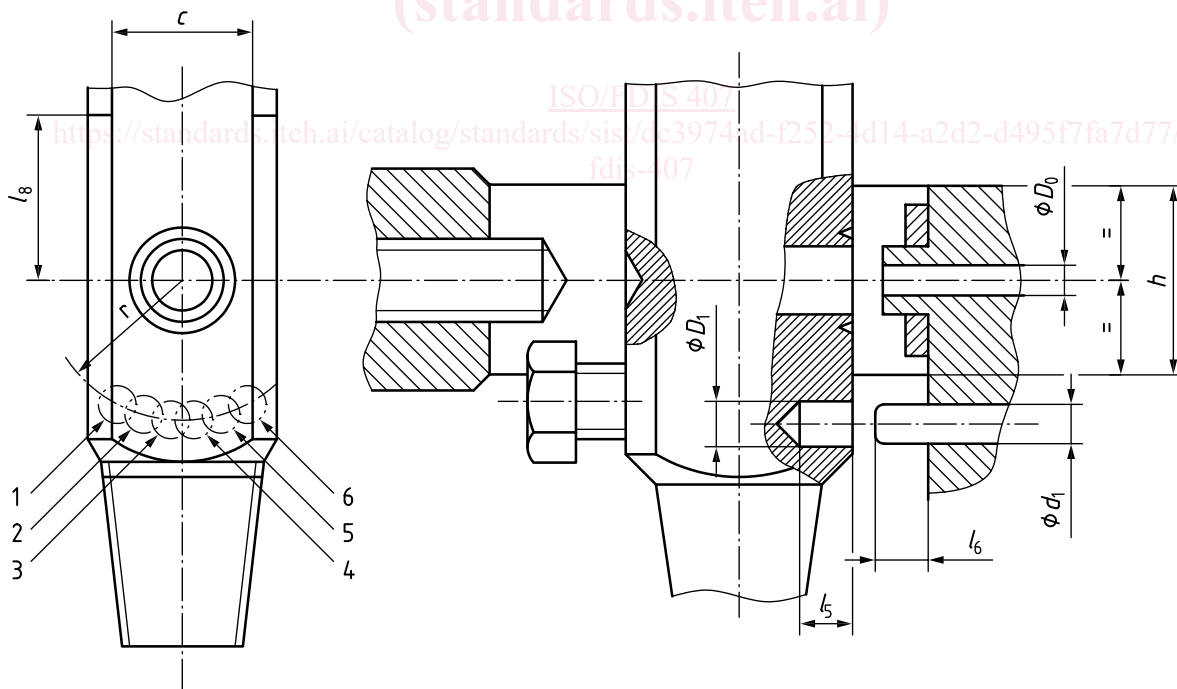

Figure 3 — Two-pin yoke-type valve connection system with the pins in a single row

6.5 Two-pin yoke-type valve connection system with the pins in a double row

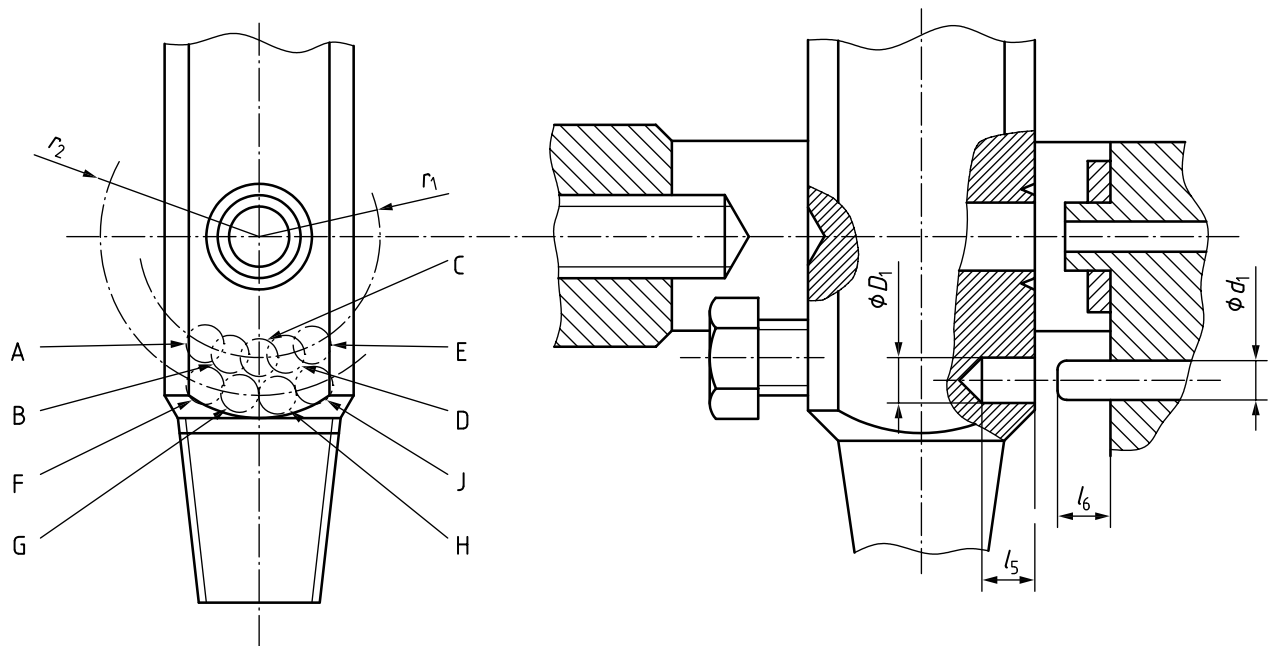

Figure 4 — Two-pin yoke-type valve connection system with the pins in a double row

6.6 Basic dimensions (standards.iteh.ai)

Table 2 — Basic dimensions for pin-index yoke-type valve connections

Dimension	mm	Dimension	mm
a	$25^{+0,8}_{-0,2}$	f	0,8 max.
b	21,8 – 22,6	g	$1,6 \pm 0,4$
c	16 min.	h^a	$20 \pm 0,5$
D	$7^{+0,2}_{-0}$	k	16,5 min.
D_0	$2,4 \pm 0,8$	l_1	44,5 min.
D_1	$4,75^{+0,1}_{-0}$	l_2	22 min.
D_2	5,8 to 5,9	l_3^b	8 min.
D_4	$6,3^{+0}_{-0,2}$	l_4^b	9,6 max.
D_5	$6^{+0}_{-0,5}$	l_5	$5,5^{+0,5}_{-0}$
D_6^c	7 min.	l_6	$5,5^{+0}_{-0,5}$
d	$6,5^{+0}_{-0,2}$	l_7	3 to 3,6
d_1	3,9 to 4,0	l_8^d	15 min.

^a Dimensions h and as alternatives q, q_1 (see 7.2). These dimensions may be chosen in order to satisfy the requirements of 7,1 g).

^b Applicable only if a projecting-type safety plug is used.

^c Dimension D_6 is the dimension at the top of the cone.

^d This dimension is very important.

^e A radius is permitted instead of a chamfer, provided dimension c is maintained.

Table 2 (continued)

Dimension	mm	Dimension	mm
d_2	$5,4^{+0}_{-0,1}$	m	1,4 min. maximum allowed: any length provided dimension c is maintained ^e
d_3	$16 \pm 0,5$	r	14,3 nom.
d_4	$9 \pm 0,2$	r_1	12 nom.
e	0,8 max.	r_2	17,5 nom.
^a Dimensions h and as alternatives q , q_1 (see 7.2). These dimensions may be chosen in order to satisfy the requirements of 7,1 g). ^b Applicable only if a projecting-type safety plug is used. ^c Dimension D_6 is the dimension at the top of the cone. ^d This dimension is very important. ^e A radius is permitted instead of a chamfer, provided dimension c is maintained.			

7 Requirements for alternative designs of yoke-type valve connections

7.1 Requirements for the design of the connecting yoke

The design of the connecting yoke shall meet the following requirements:

- a gas-tight seal shall only be possible when the pins in the yoke correspond to the holes in the valve;
- when the pins in the yoke do not correspond to the holes in the valve, a gas-tight seal shall not be possible and damage to the yoke or the valve shall be prevented;
- pins shall be fixed or assembled in such a manner that they cannot be removed by the user or become loose in service;
- the sealing washer shall be a retained fit on the yoke spigot;
- the use of more than one sealing washer is not permitted;
- the yoke shall be able to resist, without permanent deformation, the load resulting from a torque of 50 N·m applied to the valve clamping screw or locking device;
- the dimensions of the yoke shall limit the movement of the valve in the yoke to a maximum of 6° about the long axis prior to pin engagement;
- the dimension of the yoke shall not cause any physical interference with the valve and its operation or prevent an effective seat at the outlet connection.

7.2 Examples of alternative construction for the connecting yoke

Three alternative designs of pin-index yoke-type connections are shown in [Figures 5 to 7](#).

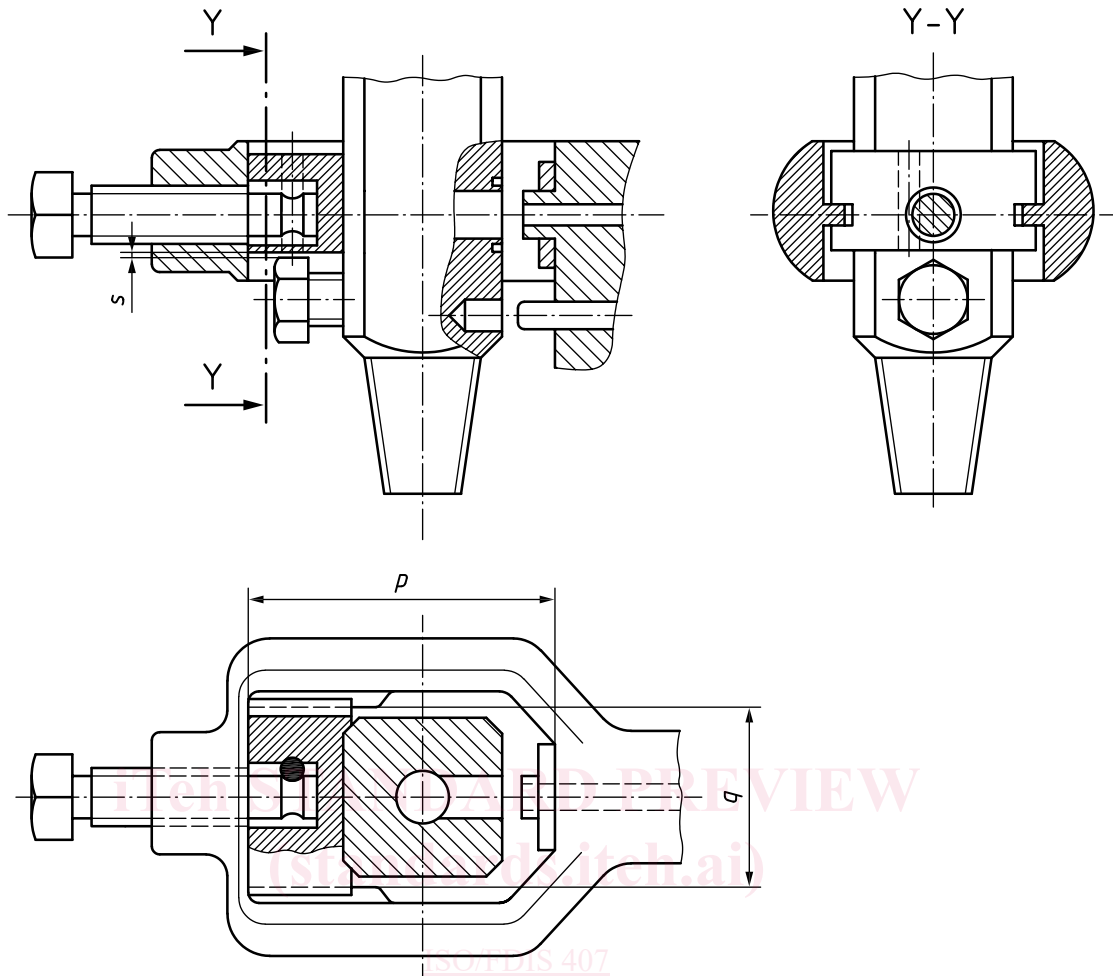

ISO/FDIS 407
<https://standards.iteh.ai/catalog/standards/sist/dc3974ad-f252-4d14-a2d2-d495f7fa7d77/iso-fdis-407>

Dimension	mm
p^a	$44,5 \pm 2$
q^b	$24^{+0,5}_{-0}$
s^c	0,8 min.

^a May be reduced to 35 mm if clearance is provided for projecting-type safety plug.
^b See the note for dimension h in [Table 2](#).
^c Applicable only if a projecting-type safety plug is used.

Figure 5 — First alternative