



Designation: E2245 – 11^{ε1}

Standard Test Method for Residual Strain Measurements of Thin, Reflecting Films Using an Optical Interferometer¹

This standard is issued under the fixed designation E2245; the number immediately following the designation indicates the year of original adoption or, in the case of revision, the year of last revision. A number in parentheses indicates the year of last reapproval. A superscript epsilon (ϵ) indicates an editorial change since the last revision or reapproval.

^{ε1} NOTE—Reference (1) was editorially revised in September 2013.

1. Scope

1.1 This test method covers a procedure for measuring the compressive residual strain in thin films. It applies only to films, such as found in microelectromechanical systems (MEMS) materials, which can be imaged using an optical interferometer, also called an interferometric microscope. Measurements from fixed-fixed beams that are touching the underlying layer are not accepted.

1.2 This test method uses a non-contact optical interferometric microscope with the capability of obtaining topographical 3-D data sets. It is performed in the laboratory.

1.3 *This standard does not purport to address all of the safety concerns, if any, associated with its use. It is the responsibility of the user of this standard to establish appropriate safety and health practices and determine the applicability of regulatory limitations prior to use.*

2. Referenced Documents

2.1 *ASTM Standards:*²

E2244 Test Method for In-Plane Length Measurements of Thin, Reflecting Films Using an Optical Interferometer

E2246 Test Method for Strain Gradient Measurements of Thin, Reflecting Films Using an Optical Interferometer

E2444 Terminology Relating to Measurements Taken on Thin, Reflecting Films

E2530 Practice for Calibrating the Z-Magnification of an Atomic Force Microscope at Subnanometer Displacement Levels Using Si(111) Monatomic Steps (Withdrawn 2015)³

2.2 *SEMI Standard:*⁴

MS2 Test Method for Step Height Measurements of Thin Films

3. Terminology

3.1 *Definitions:*

3.1.1 The following terms can be found in Terminology E2444.

3.1.2 *2-D data trace, n*—a two-dimensional group of points that is extracted from a topographical 3-D data set and that is parallel to the xz - or yz -plane of the interferometric microscope.

3.1.3 *3-D data set, n*—a three-dimensional group of points with a topographical z -value for each (x, y) pixel location within the interferometric microscope's field of view.

3.1.4 *anchor, n*—in a surface-micromachining process, the portion of the test structure where a structural layer is intentionally attached to its underlying layer.

3.1.5 *anchor lip, n*—in a surface-micromachining process, the freestanding extension of the structural layer of interest around the edges of the anchor to its underlying layer.

3.1.5.1 *Discussion*—In some processes, the width of the anchor lip may be zero.

3.1.6 *bulk micromachining, adj*—a MEMS fabrication process where the substrate is removed at specified locations.

3.1.7 *cantilever, n*—a test structure that consists of a freestanding beam that is fixed at one end.

3.1.8 *fixed-fixed beam, n*—a test structure that consists of a freestanding beam that is fixed at both ends.

3.1.9 *in-plane length (or deflection) measurement, n*—the experimental determination of the straight-line distance between two transitional edges in a MEMS device.

3.1.9.1 *Discussion*—This length (or deflection) measurement is made parallel to the underlying layer (or the xy -plane of the interferometric microscope).

¹ This test method is under the jurisdiction of ASTM Committee E08 on Fatigue and Fracture and is the direct responsibility of Subcommittee E08.05 on Cyclic Deformation and Fatigue Crack Formation.

Current edition approved Nov. 1, 2011. Published December 2011. Originally approved in 2002. Last previous edition approved in 2005 as E2245 – 05.

² For referenced ASTM standards, visit the ASTM website, www.astm.org, or contact ASTM Customer Service at service@astm.org. For *Annual Book of ASTM Standards* volume information, refer to the standard's Document Summary page on the ASTM website.

³ The last approved version of this historical standard is referenced on www.astm.org.

⁴ For referenced Semiconductor Equipment and Materials International (SEMI) standards, visit the SEMI website, www.semi.org.

3.1.10 *interferometer, n*—a non-contact optical instrument used to obtain topographical 3-D data sets.

3.1.10.1 *Discussion*—The height of the sample is measured along the z -axis of the interferometer. The x -axis is typically aligned parallel or perpendicular to the transitional edges to be measured.

3.1.11 *MEMS, adj*—microelectromechanical systems.

3.1.12 *microelectromechanical systems, adj*—in general, this term is used to describe micron-scale structures, sensors, actuators, and technologies used for their manufacture (such as, silicon process technologies), or combinations thereof.

3.1.13 *residual strain, n*—in a MEMS process, the amount of deformation (or displacement) per unit length constrained within the structural layer of interest after fabrication yet before the constraint of the sacrificial layer (or substrate) is removed (in whole or in part).

3.1.14 *sacrificial layer, n*—a single thickness of material that is intentionally deposited (or added) then removed (in whole or in part) during the micromachining process, to allow freestanding microstructures.

3.1.15 *stiction, n*—adhesion between the portion of a structural layer that is intended to be freestanding and its underlying layer.

3.1.16 (*residual*) *strain gradient, n*—a through-thickness variation (of the residual strain) in the structural layer of interest before it is released.

3.1.16.1 *Discussion*—If the variation through the thickness in the structural layer is assumed to be linear, it is calculated to be the positive difference in the residual strain between the top and bottom of a cantilever divided by its thickness. Directional information is assigned to the value of “s.”

3.1.17 *structural layer, n*—a single thickness of material present in the final MEMS device.

3.1.18 *substrate, n*—the thick, starting material (often single crystal silicon or glass) in a fabrication process that can be used to build MEMS devices.

3.1.19 *support region, n*—in a bulk-micromachining process, the area that marks the end of the suspended structure.

3.1.20 *surface micromachining, adj*—a MEMS fabrication process where micron-scale components are formed on a substrate by the deposition (or addition) and removal (in whole or in part) of structural and sacrificial layers.

3.1.21 *test structure, n*—a component (such as, a fixed-fixed beam or cantilever) that is used to extract information (such as, the residual strain or the strain gradient of a layer) about a fabrication process.

3.1.22 *transitional edge, n*—the side of a MEMS structure that is characterized by a distinctive out-of-plane vertical displacement as seen in an interferometric 2-D data trace.

3.1.23 *underlying layer, n*—the single thickness of material directly beneath the material of interest.

3.1.23.1 *Discussion*—This layer could be the substrate.

3.2 *Symbols:*

3.2.1 *For Calibration:*

$\sigma_{\delta same}$ = the maximum of two uncalibrated values (σ_{same1}

and σ_{same2}) where σ_{same1} is the standard deviation of the six step height measurements taken on the physical step height standard at the same location before the data session and σ_{same2} is the standard deviation of the six measurements taken at this same location after the data session

σ_{cert} = the certified one sigma uncertainty of the physical step height standard used for calibration

σ_{noise} = the standard deviation of the noise measurement, calculated to be one-sixth the value of R_{tave} minus R_{ave}

σ_{Rave} = the standard deviation of the surface roughness measurement, calculated to be one-sixth the value of R_{ave}

σ_{xcal} = the standard deviation in a ruler measurement in the interferometric microscope’s x -direction for the given combination of lenses

σ_{ycal} = the standard deviation in a ruler measurement in the interferometric microscope’s y -direction for the given combination of lenses

cal_x = the x -calibration factor of the interferometric microscope for the given combination of lenses

cal_y = the y -calibration factor of the interferometric microscope for the given combination of lenses

cal_z = the z -calibration factor of the interferometric microscope for the given combination of lenses

$cert$ = the certified (that is, calibrated) value of the physical step height standard

$ruler_x$ = the interferometric microscope’s maximum field of view in the x -direction for the given combination of lenses as measured with a 10- μ m grid (or finer grid) ruler

$ruler_y$ = the interferometric microscope’s maximum field of view in the y -direction for the given combination of lenses as measured with a 10- μ m grid (or finer grid) ruler

$scope_x$ = the interferometric microscope’s maximum field of view in the x -direction for the given combination of lenses

$scope_y$ = the interferometric microscope’s maximum field of view in the y -direction for the given combination of lenses

x_{res} = the calibrated resolution of the interferometric microscope in the x -direction

$\bar{z}_{\delta same}$ = the uncalibrated average of the six calibration measurements from which $\sigma_{\delta same}$ is found

z_{drift} = the uncalibrated positive difference between the average of the six calibration measurements taken before the data session (at the same location on the physical step height standard used for calibration) and the average of the six calibration measurements taken after the data session (at this same location)

z_{lin} = over the instrument’s total scan range, the maximum relative deviation from linearity, as quoted by the instrument manufacturer (typically less than 3 %)

z_{res} = the calibrated resolution of the interferometric microscope in the z -direction

\bar{z}_{ave} = the average of the calibration measurements taken along the physical step height standard before and after the data session

3.2.2 *For In-plane Length Measurement:*

α = the misalignment angle

L = the in-plane length measurement of the fixed-fixed beam

L_{offset} = the in-plane length correction term for the given type of in-plane length measurement taken on similar structures

when using similar calculations and for the given combination of lenses for a given interferometric microscope

$v1_{end}$ = one endpoint of the in-plane length measurement

$v2_{end}$ = another endpoint of the in-plane length measurement

$x1_{upper}$ = the calibrated x -value that most appropriately locates the upper corner associated with Edge 1 in Trace t

$x2_{upper}$ = the calibrated x -value that most appropriately locates the upper corner associated with Edge 2 in Trace t

y_a = the calibrated y -value associated with Trace a'

y_e = the calibrated y -value associated with Trace e'

3.2.3 For Residual Strain Measurement:

$\delta_{ercorrection}$ = the relative residual strain correction term

ϵ_r = the residual strain

A_F = the amplitude of the cosine function used to model the first abbreviated data trace

A_S = the amplitude of the cosine function used to model the second abbreviated data trace

L_0 = the calibrated length of the fixed-fixed beam if there are no applied axial-compressive forces

L_c = the total calibrated length of the curved fixed-fixed beam (as modeled with two cosine functions) with $v1_{end}$ and $v2_{end}$ as the calibrated v values of the endpoints

L_{cF} = the calibrated length of the cosine function modeling the first curve with $v1_{end}$ and i as the calibrated v values of the endpoints

L_{cS} = the calibrated length of the cosine function modeling the second curve with i and $v2_{end}$ as the calibrated v values of the endpoints

$L_{e'}$ = the calibrated effective length of the fixed-fixed beam calculated as a straight-line measurement between v_{eF} and v_{eS}

$n1_t$ = indicative of the data point uncertainty associated with the chosen value for $x1_{upper}$, with the subscript “ t ” referring to the data trace. If it is easy to identify one point that accurately locates the upper corner of Edge 1, the maximum uncertainty associated with the identification of this point is $n1_{r_{res}cal_x}$, where $n1_t=1$.

$n2_t$ = indicative of the data point uncertainty associated with the chosen value for $x2_{upper}$, with the subscript “ t ” referring to the data trace. If it is easy to identify one point that accurately locates the upper corner of Edge 2, the maximum uncertainty associated with the identification of this point is $n2_{r_{res}cal_x}$, where $n2_t=1$.

s = equals 1 for fixed-fixed beams deflected in the minus z -direction of the interferometric microscope, and equals -1 for fixed-fixed beams deflected in the plus z -direction

t = the thickness of the suspended, structural layer

v_{eF} = the calibrated v value of the inflection point of the cosine function modeling the first abbreviated data trace

v_{eS} = the calibrated v value of the inflection point of the cosine function modeling the second abbreviated data trace

3.2.4 For Combined Standard Uncertainty Calculations:

ϵ_{r-high} = in determining the combined standard uncertainty value for the residual strain measurement, the highest value for ϵ_r given the specified variations

ϵ_{r-low} = in determining the combined standard uncertainty value for the residual strain measurement, the lowest value for ϵ_r given the specified variations

$\sigma_{Lrepeat(samp)}$ = the in-plane length repeatability standard deviation (for the given combination of lenses for the given interferometric microscope) as obtained from test structures fabricated in a process similar to that used to fabricate the sample and when the transitional edges face each other

$\sigma_{repeat(samp)}$ = the relative residual strain repeatability standard deviation as obtained from fixed-fixed beams fabricated in a process similar to that used to fabricate the sample

R_{ave} = the calibrated surface roughness of a flat and leveled surface of the sample material calculated to be the average of three or more measurements, each measurement taken from a different 2-D data trace

R_{tave} = the calibrated peak-to-valley roughness of a flat and leveled surface of the sample material calculated to be the average of three or more measurements, each measurement taken from a different 2-D data trace

U_{er} = the expanded uncertainty of a residual strain measurement

u_{cer} = the combined standard uncertainty of a residual strain measurement

u_{cert} = the component in the combined standard uncertainty calculation for residual strain that is due to the uncertainty of the value of the physical step height standard used for calibration

$u_{correction}$ = the component in the combined standard uncertainty calculation for residual strain that is due to the uncertainty of the correction term

u_{drift} = the component in the combined standard uncertainty calculation for residual strain that is due to the amount of drift during the data session

u_L = the component in the combined standard uncertainty calculation for residual strain that is due to the measurement uncertainty of L

u_{linear} = the component in the combined standard uncertainty calculation for residual strain that is due to the deviation from linearity of the data scan

u_{noise} = the component in the combined standard uncertainty calculation for residual strain that is due to interferometric noise

u_{Rave} = the component in the combined standard uncertainty calculation for residual strain that is due to the sample's surface roughness

$u_{repeat(samp)}$ = the component in the combined standard uncertainty calculation for residual strain that is due to the repeatability of residual strain measurements taken on fixed-fixed beams processed similarly to the one being measured

$u_{repeat(shs)}$ = the component in the combined standard uncertainty calculation for residual strain that is due to the repeatability of measurements taken on the physical step height standard

u_W = the component in the combined standard uncertainty calculation for residual strain that is due to variations across the width of the fixed-fixed beam

u_{xcal} = the component in the combined standard uncertainty calculation for residual strain that is due to the uncertainty of the calibration in the x -direction

u_{xres} = the component in the combined standard uncertainty calculation for residual strain that is due to the resolution of the

interferometric microscope in the x -direction as pertains to the data points chosen along the fixed-fixed beam

u_{zres} = the component in the combined standard uncertainty calculation for residual strain that is due to the resolution of the interferometric microscope in the z -direction

3.2.5 For Round Robin Measurements:

ϵ_{rave} = the average residual strain value for the repeatability or reproducibility measurements that is equal to the sum of the ϵ_r values divided by n

L_{des} = the design length of the fixed-fixed beam

n = the number of repeatability or reproducibility measurements

u_{cerave} = the average combined standard uncertainty value for the residual strain measurements that is equal to the sum of the u_{cer} values divided by n

3.2.6 For Adherence to the Top of the Underlying Layer:

A = in a surface micromachining process, the minimum thickness of the structural layer of interest as measured from the top of the structural layer in the anchor area to the top of the underlying layer

H = in a surface micromachining process, the anchor etch depth, which is the amount the underlying layer is etched away in the interferometric microscope's minus z -direction during the patterning of the sacrificial layer

J = in a surface micromachining process, the positive distance (equal to the sum of $j_a, j_b, j_c,$ and j_d) between the bottom of the suspended, structural layer and the top of the underlying layer

j_a = in a surface micromachining process, half the peak-to-peak value of the roughness of the underside of the suspended, structural layer in the interferometric microscope's z -direction. This is due to the roughness of the topside of the sacrificial layer.

j_b = in a surface micromachining process, the tilting component of the suspended, structural layer that accounts for the

deviation in the distance between the bottom of the suspended, structural layer and the top of the underlying layer that is not due to residue or the roughness of the surfaces. This component can be positive or negative.

j_c = in a surface micromachining process, the height in the interferometric microscope's z -direction of any residue present between the bottom of the suspended, structural layer and the top of the underlying layer

j_d = in a surface micromachining process, half the peak-to-peak value of the surface roughness of the topside of the underlying layer

$z_{reg\#1}$ = in a surface micromachining process, the interferometric z value of the point of maximum deflection along the fixed-fixed beam with respect to an anchor lip

$z_{reg\#2}$ = in a surface micromachining process, a representative interferometric z value of the group of points within the large anchor area

3.2.7 Discussion—The symbols above are used throughout this test method. However, when referring to y values, the letter “ y ” can replace the first letter in the symbols (or the subscript of the symbols) above that start with the letter “ x .”

4. Summary of Test Method

4.1 A surface-micromachined fixed-fixed beam is shown in Figs. 1-3. After fabrication, this fixed-fixed beam bends in the out-of-plane z -direction. An optical interferometric microscope (such as shown in Fig. 4) is used to obtain a topographical 3-D data set. 2-D data traces beside the fixed-fixed beam (such as Traces a', a, e, and e', shown in Fig. 3 and Fig. 5) and along the top of the fixed-fixed beam (such as Traces b, c, and d, shown in Fig. 3 and Fig. 6) are extracted from this 3-D data set for the residual strain analysis.

4.2 The residual strain is determined from measurements of the in-plane length and the curved length of the fixed-fixed

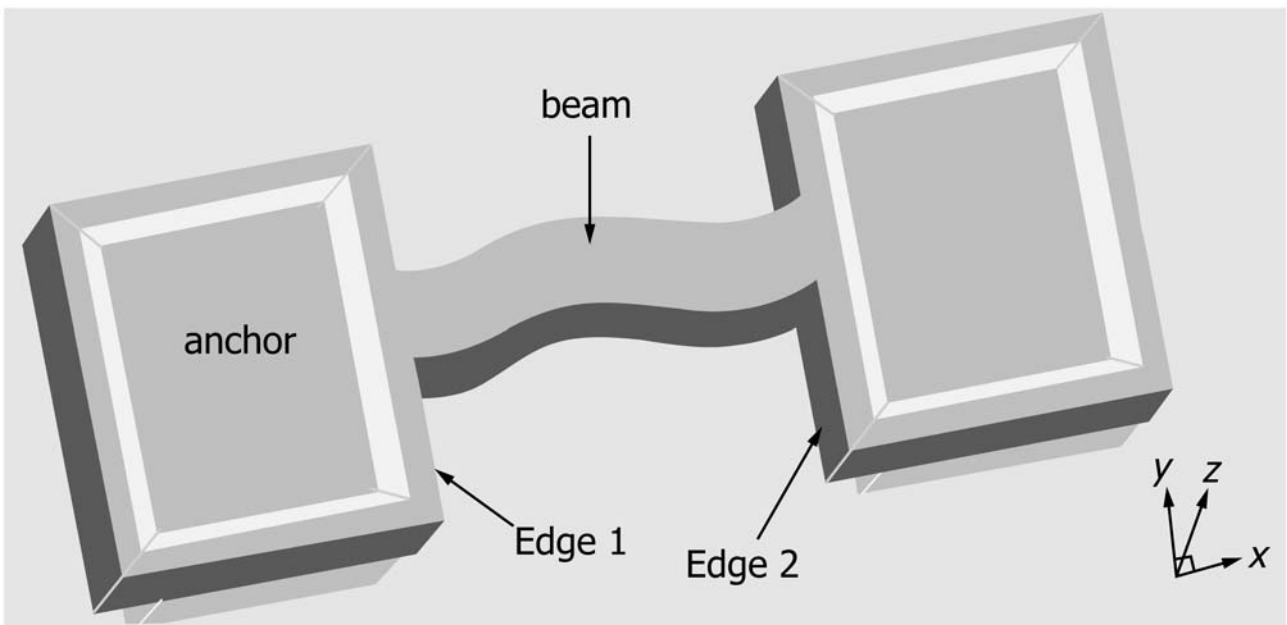
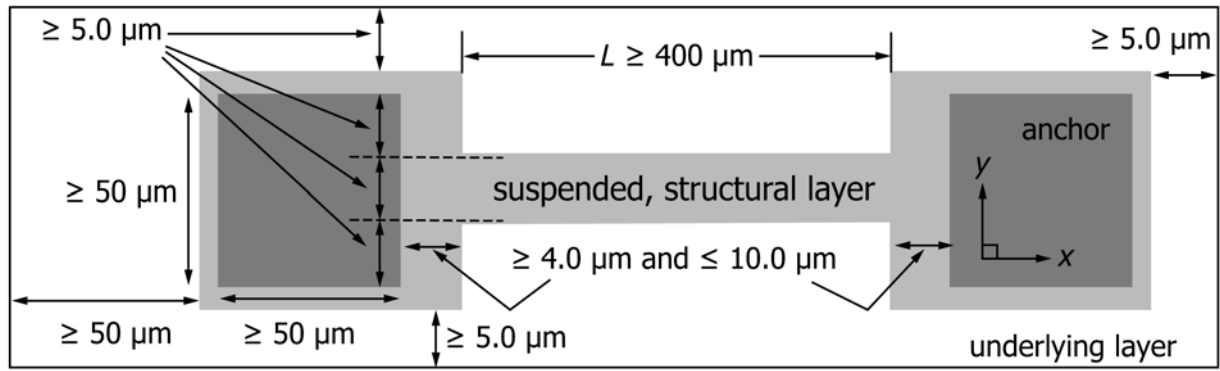

FIG. 1 Three-Dimensional View of Surface-Micromachined Fixed-Fixed Beam



NOTE 1—The underlying layer is beneath this test structure.

NOTE 2—The structural layer of interest is included in both the light and dark gray areas.

NOTE 3—The light gray area is suspended in air after fabrication.

NOTE 4—The dark gray areas (the anchors) are the designed cuts in the sacrificial layer. This is where the structural layer contacts the underlying layer.

FIG. 2 Design Dimensions for Fixed-Fixed Beam in Fig. 1

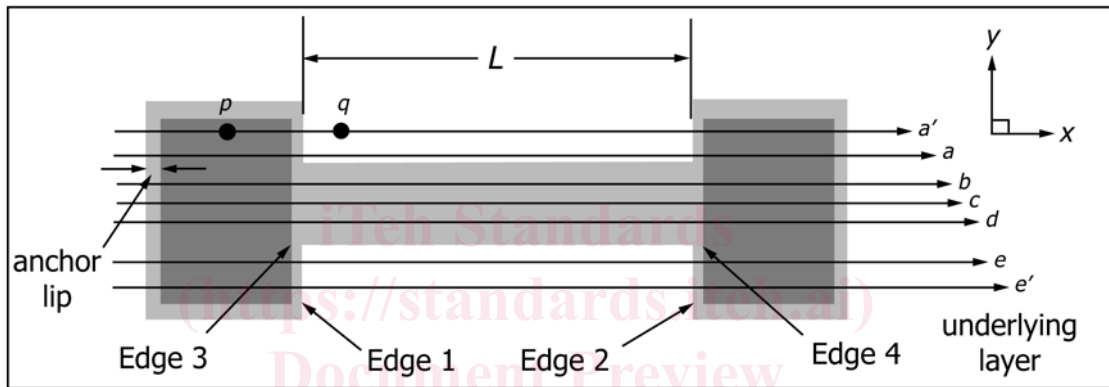

NOTE 1—The 2-D data traces (a' and e') are used to calculate the misalignment angle, α .

NOTE 2—The 2-D data traces (a' , a , e , and e') are used to determine L .

NOTE 3—Traces b , c , and d are used to determine the residual strain and calculate u_w . They can be used to ascertain if the fixed-fixed beam is adhered to the top of the underlying layer if enough data points are measured on the top of the underlying layer to the left of the anchor.

FIG. 3 Top View of Fixed-Fixed Beam

beam. The in-plane length is determined between Edges 1 and 2 (shown in Fig. 3) using Traces a' , a , e , and e' in a similar manner as specified in Test Method E2244. For Traces b , c , and d , the curved length of the fixed-fixed beam is determined with two cosine functions modeling the out-of-plane shape of the fixed-fixed beam. These functions are merged at the minimum or maximum deflection. Three data points are chosen to define each cosine function. The residual strain is the average of the residual strain values calculated for Traces b , c , and d .

4.3 For a surface-micromachined fixed-fixed beam, to obtain three data points that define each cosine function: (1) select the two transitional edges, (2) align the transitional edges in the field of view, (3) obtain a 3-D data set, (4) determine the endpoints of the in-plane length measurement and associated uncertainties, and (5) for Traces b , c , and d , obtain three data points that define each cosine function. (This procedure may need to be modified for a bulk-micromachined fixed-fixed beam.)

4.4 To calculate the residual strain for each data trace (b , c , and d): (1) account for any misalignment, (2) determine the in-plane length of the fixed-fixed beam and the endpoints, (3)

for Trace c , solve three equations for three unknowns to obtain each cosine function, (4) plot the functions with the data from Trace c , (5) calculate the length of the curved fixed-fixed beam for Trace c , (6) calculate the residual strain for Trace c , and (7) repeat steps 3 through 6 for Traces b and d . The residual strain is calculated as the average of the three residual strain values obtained from the three data traces.

4.5 The equations used to find the combined standard uncertainty are given in Annex A1.

4.6 Appendix X1 is used to determine if the fixed-fixed beam has adhered to the top of the underlying layer.

5. Significance and Use

5.1 Residual strain measurements are an aid in the design and fabrication of MEMS devices. The value for residual strain can be used in Young's modulus calculations.

6. Interferences

6.1 Measurements from fixed-fixed beams that are touching the underlying layer (as ascertained in Appendix X1) are not accepted.

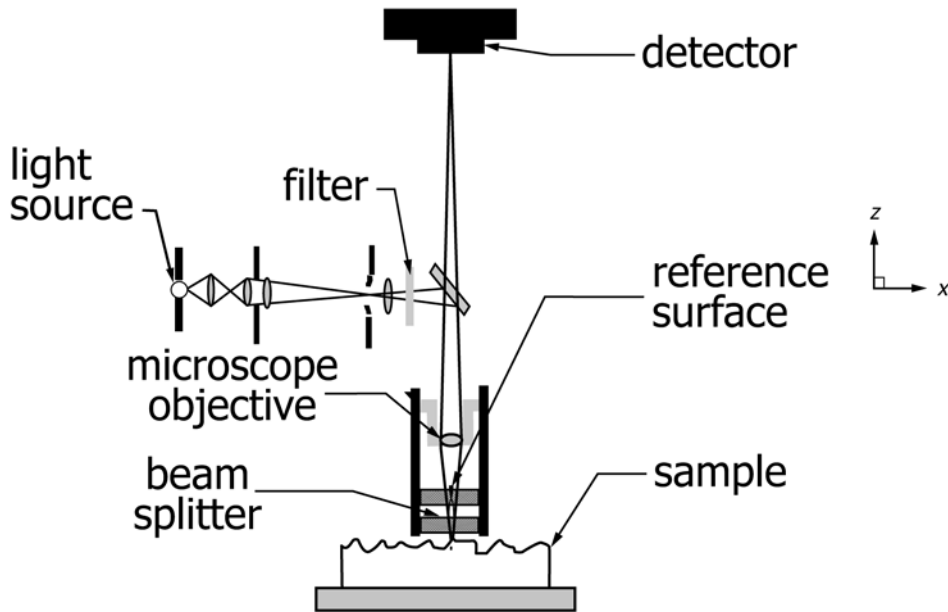

FIG. 4 Schematic of an Optical Interferometric Microscope

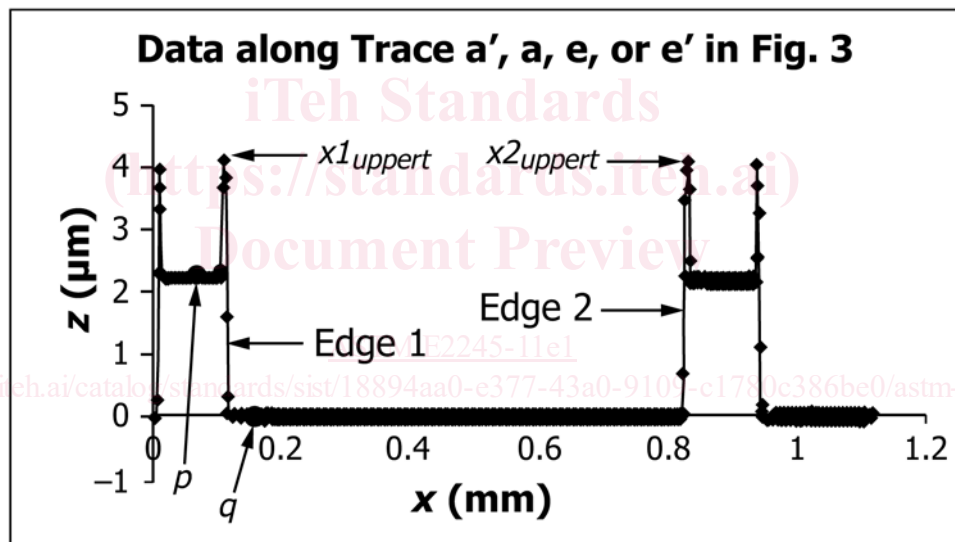

FIG. 5 2-D Data Trace Used to Find $x1_{upper}$ and $x2_{upper}$

7. Apparatus⁵ (1-3)⁶

7.1 *Non-contact Optical Interferometric Microscope*, capable of obtaining a topographical 3-D data set and exporting

⁵ The same apparatus is used (or can be used) in Test Method E2244, Test Method E2246, and SEMI Test Method MS2.

⁶ The boldface numbers in parentheses refer to the list of references at the end of this standard.

a 2-D data trace. Fig. 4 is a schematic of such an interferometric microscope. However, any non-contact optical interferometric microscope that has pixel-to-pixel spacings as specified in Table 1 and that is capable of performing the test procedure with a vertical resolution less than 1 nm is permitted. The interferometric microscope must be capable of measuring step heights to at least 5 μm higher than the step height to be measured.

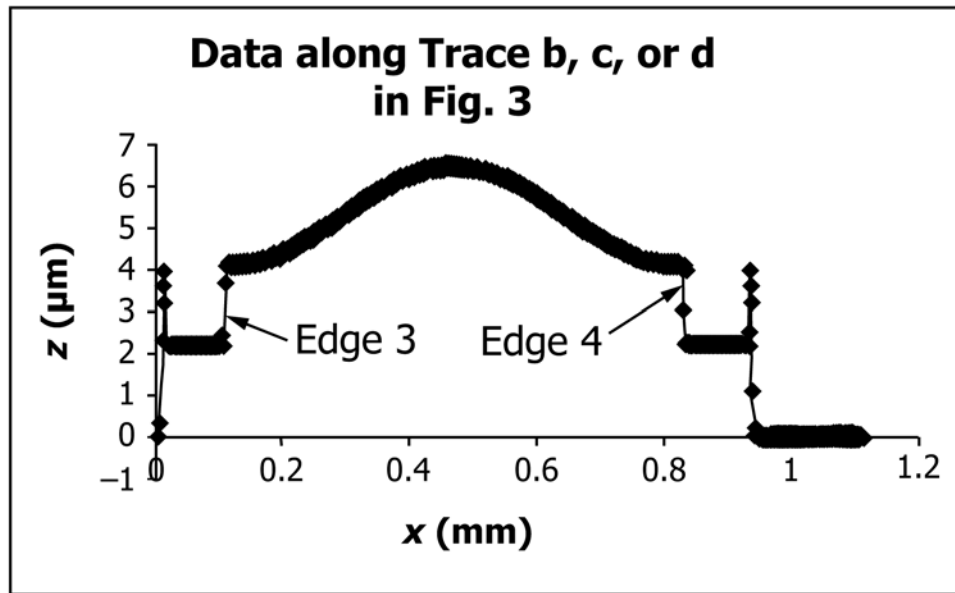

FIG. 6 2-D Data Trace Along a Fixed-Fixed Beam

TABLE 1 Interferometric Microscope Pixel-to-Pixel Spacing Requirements

Magnification, \times	Pixel-to-Pixel Spacing, μm
5	< 2.00
10	< 1.00
20	< 0.50
40	< 0.40
80	< 0.20

NOTE 1—Table 1 does not include magnifications at or less than 2.5 \times because the pixel-to-pixel spacings will be too large for this work, or the possible introduction of a second set of interferometric fringes in the data set at these magnifications can adversely affect the data, or both. Therefore, magnifications at or less than 2.5 \times shall not be used.

7.2 *10- μm -grid (or finer grid) Ruler*, for calibrating the interferometric microscope in the xy -plane. This ruler should be longer than the maximum field of view at the lowest magnification.

7.3 *Double-sided Physical Step Height Standard*, for calibrating the interferometric microscope in the out-of-plane z -direction.

7.4 *Thermometer (optional)*, to record the temperature during measurement.

7.5 *Humidity Meter (optional)*, to record the relative humidity during measurement.

8. Test Units

8.1 *Fixed-fixed Beam Test Structures Fabricated in Either a Surface-micromachining or Bulk-micromachining Process*—The design of a representative surface-micromachined fixed-fixed beam is specified below.

8.1.1 The fixed-fixed beam shall be wide enough (for example, 5- μm wide, as shown in Fig. 2) so that obtaining a 2-D data trace (such as Trace c in Fig. 3) along its length is not a difficult task.

8.1.2 The fixed-fixed beam shall be long enough (for example, $L \geq 400 \mu\text{m}$, as shown in Fig. 2) so that it exhibits out-of-plane curvature in the z -direction (as shown in Fig. 1 and Fig. 6). The approximate location of the two inflection points, created by this curvature, should be relatively easy to determine from a 2-D data trace (such as Trace b, c, or d in Fig. 3, as shown in Fig. 6) taken along the length of the beam.

8.1.3 The anchor lip between Edges 1 and 3 in Fig. 3 and between Edges 2 and 4 shall be wide enough to include at least two data points (three would be better). If the pixel-to-pixel spacing is 2.00 μm , then these anchor lips should be at least two times greater (or 4.0 μm , as shown in Fig. 2). At the same time, they should be less than or equal to 10.0- μm wide.

8.1.4 The cut in the sacrificial layer that defines the anchor should be at least 50 μm by 50 μm (as shown in Fig. 2) to determine if the fixed-fixed beam has adhered to the top of the underlying layer as ascertained in Appendix X1. If a backside etch is used to eliminate stiction concerns, the interferometric optics (or the 3-D data set) can be leveled with respect to these anchors.

NOTE 2—If one or more “posts” are used in the anchor area, a post layer is not considered the underlying layer. The post or posts connect the underlying layer to the sample material, in which case replace the words “cut in the sacrificial layer” with the words “post or posts.”

8.1.5 Each anchor shall extend beyond the width of the fixed-fixed beam in the $\pm y$ -directions (for example, at least 5.0 μm , as shown in Fig. 2) such that obtaining Traces a', a, e, and e' in Fig. 3 is not a difficult task.

8.1.6 There should be only one fixed-fixed beam for each anchor (as shown in Fig. 2).

8.1.7 The underlying layer should be unpatterned beneath the structural layer of interest and should extend at least 5.0 μm beyond the outermost edges of this patterned structural layer (as shown in Fig. 2). The underlying layer should also extend at least 50 μm beyond the anchor lip in the minus x -direction (as shown in this figure) to ascertain if the fixed-fixed beam has

adhered to the top of the underlying layer, if necessary. This assumes that a backside etch is not used to eliminate stiction concerns.

NOTE 3—Any tilt in the sample (or the sample data) is initially eliminated (or eliminated) by leveling the interferometric optics (or the 3-D data set) with respect to the top of the exposed underlying layer (or with respect to the top of flat regions of the sample). If the exposed underlying layer straddling the fixed-fixed beam in Fig. 2 is used for this purpose, no other structures should be designed in these areas.

8.1.8 A sufficient number of fixed-fixed beams (preferably of different lengths) should be fabricated in order to obtain at least one fixed-fixed beam after fabrication, which exhibits out-of-plane curvature in the z -direction and which has not adhered to the top of the underlying layer.

8.1.9 If a backside etch is used to eliminate stiction concerns, consult the fabrication service or facility for appropriate design considerations. Avoid or minimize having any layer edges in or coincident with both the designed fixed-fixed beam and the fabricated fixed-fixed beam. It is also recommended that any resulting vertical transitions in the fixed-fixed beam be as close to an anchor as possible.

8.1.10 If two layers of polysilicon are used within an anchor design, a more rigid and reliable attachment of the fixed-fixed beam to the anchor will result. Consult the fabrication service or facility for appropriate design considerations.

9. Calibration⁷ (1-3)

9.1 Calibrate the interferometric microscope in the x - and y -directions using a 10- μm -grid (or finer grid) ruler. Do this for each combination of lenses used for the measurements. Calibrate in the xy -plane on a yearly basis.

9.1.1 Orient the ruler in the x -direction using crosshairs, if available. Record $ruler_x$ as measured on the interferometric microscope's screen. Determine $\sigma_{y\text{cal}}$.

9.1.2 Orient the ruler in the y -direction using crosshairs, if available. Record $ruler_y$ as measured on the interferometric microscope's screen. Determine $\sigma_{x\text{cal}}$.

9.1.3 Determine the x - and y -calibration factors using the following equations:

$$cal_x = \frac{ruler_x}{scope_x} \quad (1)$$

and

$$cal_y = \frac{ruler_y}{scope_y} \quad (2)$$

NOTE 4—Multiply the x - and y -data values obtained during the data session by the appropriate calibration factor to obtain calibrated x - and y -data values.

9.2 Calibrate the interferometric microscope in the out-of-plane z -direction using the certified value of a physical step height standard. Do this for each combination of lenses used for the measurements.

NOTE 5—Having the physical step height standard calibrated at NIST⁸

⁷ The same calibration procedure is used as in Test Method E2244 and Test Method E2246. A similar calibration in the z -direction is used in SEMI Test Method MS2.

⁸ Physical step height standards are calibrated at NIST as specified in (4), Appendix A of (5), and Test Method E2530.

lowers the total uncertainty in the certified value.

9.2.1 Before the data session:

9.2.1.1 Take six measurements of the height of the physical step height standard using six 3-D data sets to accomplish this task. These measurements should be taken spread out evenly along the physical step height standard, being careful to obtain these measurements within the certified range (both along the length and width) of the physical step height standard. If single-sided step height measurements are taken, three measurements should be taken along each side of the physical step height standard. Record \bar{z}_{before} , the mean value of the six measurements, and σ_{before} , the standard deviation of the six measurements.

9.2.1.2 Take six measurements of the height of the physical step height standard (using six 3-D data sets) at the same location on the physical step height standard, being careful to obtain these measurements within the certified range (both along the length and width) of the physical step height standard. Record \bar{z}_{same1} , the mean value of the six measurements, and σ_{same1} , the standard deviation of the six measurements.

9.2.2 After the data session:

9.2.2.1 Repeat 9.2.1.1 recording \bar{z}_{after} as the mean value of the six measurements and σ_{after} as the standard deviation of the six measurements.

9.2.2.2 Repeat 9.2.1.2 at the same location as the measurements taken before the data session recording \bar{z}_{same2} as the mean value of the six measurements and σ_{same2} as the standard deviation of the six measurements.

9.2.3 Determine the z -calibration factor:

9.2.3.1 Calculate the mean value of the twelve measurements, \bar{z}_{ave} , from 9.2.1.1 and 9.2.2.1 using the following equation:

$$\bar{z}_{\text{ave}} = \frac{\bar{z}_{\text{before}} + \bar{z}_{\text{after}}}{2} \quad (3)$$

9.2.3.2 Determine the z -calibration factor using the following equation:

$$cal_z = \frac{cert}{\bar{z}_{\text{ave}}} \quad (4)$$

NOTE 6—Multiply the z -data values obtained during the data session by cal_z to obtain calibrated z -data values.

9.2.4 Obtain the additional parameters that will be used in Annex A1 for the combined standard uncertainty calculations.

9.2.4.1 Calculate z_{drift} using the following equation:

$$z_{\text{drift}} = |\bar{z}_{\text{same1}} - \bar{z}_{\text{same2}}| \quad (5)$$

9.2.4.2 Calculate $\bar{z}_{6\text{same}}$ and $\sigma_{6\text{same}}$ using the following equations:

$$\text{if } \sigma_{\text{same1}} \geq \sigma_{\text{same2}}, \text{ then } \sigma_{6\text{same}} = \sigma_{\text{same1}} \text{ and } \bar{z}_{6\text{same}} = \bar{z}_{\text{same1}}, \text{ and} \quad (6)$$

$$\text{if } \sigma_{\text{same1}} < \sigma_{\text{same2}}, \text{ then } \sigma_{6\text{same}} = \sigma_{\text{same2}} \text{ and } \bar{z}_{6\text{same}} = \bar{z}_{\text{same2}} \quad (7)$$

9.2.4.3 Record σ_{cert} , z_{lin} , x_{res} , and z_{res} as defined in 3.2.1 for use in Annex A1.

9.2.4.4 Obtain R_{ave} and R_{ave} as defined in 3.2.4 for use in Annex A1.

10. Procedure (1-3)

10.1 For a surface-micromachined fixed-fixed beam, to obtain three data points that define each cosine function, five steps are taken: (1) select the two transitional edges, (2) align the transitional edges in the field of view, (3) obtain a 3-D data set, (4) determine the endpoints of the in-plane length measurement and associated uncertainties, and (5) for Traces b, c, and d, obtain three data points that define each cosine function.

NOTE 7—The procedure that follows may need to be modified for the given fixed-fixed beam. For a bulk-micromachining process, refer to Fig. 7, Fig. 8, and Fig. 9 instead of Fig. 3, Fig. 5, and Fig. 6, respectively. The bulk-micromachined fixed-fixed beam in Fig. 7 consists of four oxide layer thicknesses (1) and this test method uses a single-layered beam model. Therefore, the resulting residual strain would be considered an effective residual strain. Additional modifications may also need to be made as appropriate, for example, when considering a surface-micromachined fixed-fixed beam with a backside etch.

10.2 *Select the Two Transitional Edges:*

10.2.1 Select the two transitional edges that define the in-plane length measurement (for example, Edges 1 and 2 in Fig. 3). These are the first and second transitional edges.

10.3 *Align the Transitional Edges in the Field of View:*

10.3.1 Align the two transitional edges from 10.2.1 parallel or perpendicular to the *x*- (or *y*-) axis of the interferometric microscope. If the interferometric microscope’s pixel-to-pixel spacing is smaller in the *x*-direction than in the *y*-direction, it is preferable to orient the sample such that the in-plane length measurement is taken in the *x*-direction.

NOTE 8—The first transitional edge has *x* (or *y*) values that are less than the *x* (or *y*) values associated with the second transitional edge.

10.4 *Obtain a 3-D Data Set:*

10.4.1 Obtain a 3-D data set that contains 2-D data traces (*a*) parallel to the in-plane length of the fixed-fixed beam and (*b*) perpendicular to the selected transitional edges in 10.2.1.

10.4.1.1 Record the room temperature and relative humidity for informational purposes.

10.4.1.2 Use the most powerful objective possible (while choosing the appropriate field of view lens, if applicable) given the sample areas to be investigated.

10.4.1.3 Select the detector array size that achieves the best lateral resolution.

10.4.1.4 Visually align the transitional edges in the field of view using crosshairs (if available).

10.4.1.5 Adjust the intensity with respect to the brightest layer of interest.

10.4.1.6 Eliminate any tilt in the sample by nulling the fringes on the top of flat regions of the sample that are symmetrically located with respect to the fixed-fixed beam (for example, on the top of the exposed underlying layer in Fig. 3 that straddles the fixed-fixed beam). The fringes are typically nulled for the measurement; however, if fringes are present, they should be perpendicular to the two transitional edges defining the in-plane length measurement.

10.4.1.7 Recheck the sample alignment and bring the fringes to just past the topmost structure within the field of view.

10.4.1.8 Take an average of at least three measurements to comprise one 3-D data set. Level the 3-D data set with respect to flat regions of the sample that are symmetrically located with respect to the fixed-fixed beam (for example, with respect to the top of the exposed underlying layer in Fig. 3, with regions chosen to be symmetrically located with respect to the fixed-fixed beam).

10.4.1.9 From the leveled 3-D data set, extract Traces *a'*, *a*, *b*, *c*, *d*, *e*, and *e'* as shown in Fig. 3. Calibrate these data traces in the *x*- (or *y*-) and *z*-directions.

NOTE 9—In a bulk-micromachining process, the edges of the etched out

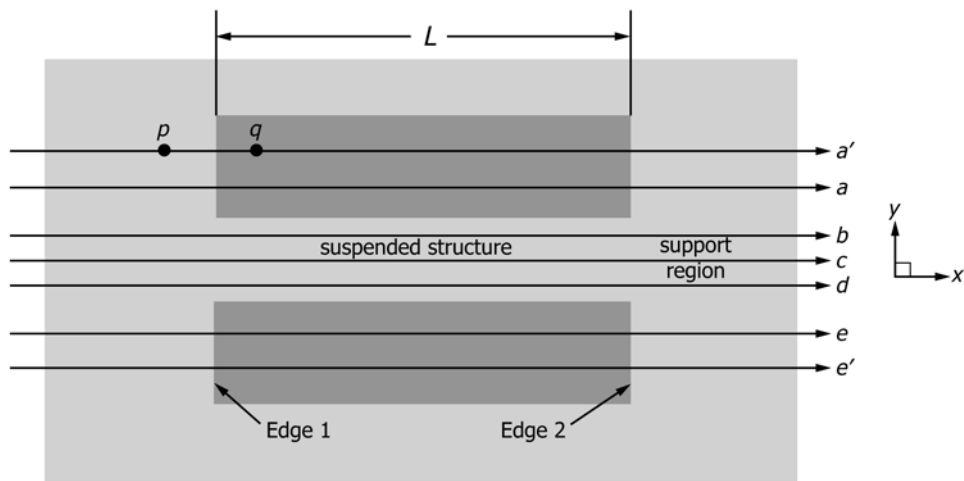

NOTE 1—The central beam is suspended above a micromachined cavity.

NOTE 2—The dark gray areas are the visible parts of the micromachined cavity.

NOTE 3—The remaining light gray area around the outside of the visible portion of the cavity is suspended in air, attached underneath to the substrate, or both.

NOTE 4—Traces *a'* and *e'* are used to determine the misalignment angle, α . Traces *a'*, *a*, *e*, and *e'* are used to calculate *L*.

NOTE 5—Traces *b*, *c*, and *d* are used to calculate residual strain and u_w .

FIG. 7 Top View of Bulk-Micromachined Fixed-Fixed Beam

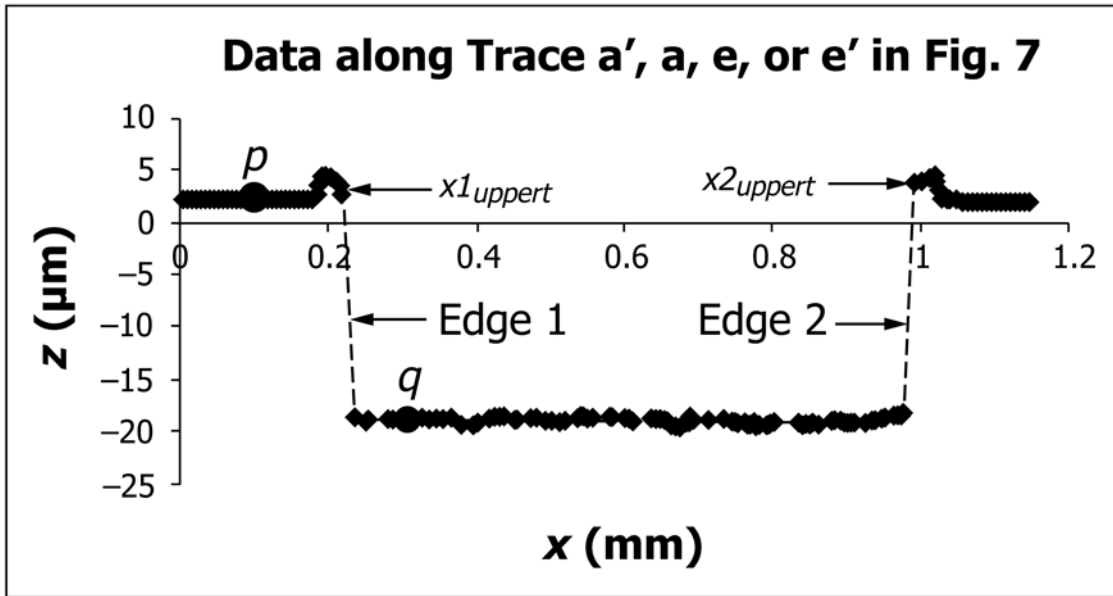

NOTE 1—Data points are missing along and near Edges 1 and 2.

FIG. 8 2-D Data Trace Used to Find $x1_{uppert}$ and $x2_{uppert}$

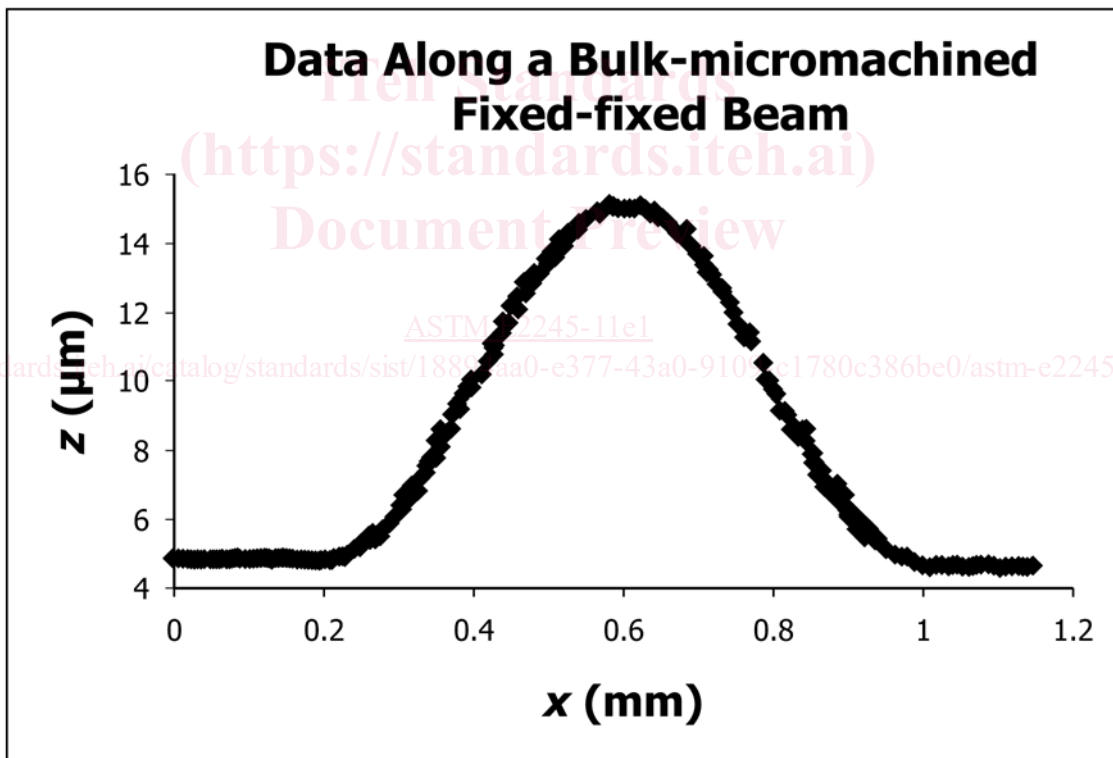

NOTE 1—This is a 2-D data trace (*b*, *c*, or *d*) along a fixed-fixed beam similar to that shown in Fig. 7.

NOTE 2—Some data points are missing along this trace.

FIG. 9 2-D Data Trace Used in Residual Strain Calculation

cavity may be jagged, therefore, choose Traces *a'*, *a*, *e*, and *e'* that contain representative endpoints.

10.4.1.10 In Trace *c*, examine the data associated with the suspended portion of the fixed-fixed beam. If the fixed-fixed beam bends towards the underlying layer and there is a

question as to whether or not it has adhered to the top of the underlying layer, follow the steps in Appendix X1 at this point. For a bulk-micromachining process, continue from 10.1 with another fixed-fixed beam.