

ISO 1496-1:2013/~~DAM~~~~F~~~~DAM~~ 2:2023(~~E~~2024(en))

~~2023-09-26~~

2024-03-06

ISO/TC 104/SC 1

Secretariat: AFNOR

Series 1 freight containers — Specification and testing —
Part 1: General cargo containers for general purposes —
Amendment 2

*Conteneurs de la série 1 — Spécifications et essais —
Partie 1: Conteneurs d'usage général pour marchandises diverses —
Amendement 2*

iTeh Standards
(<https://standards.iteh.ai>)
Document Preview

[ISO 1496-1:2013/FDAmd 2](https://standards.iteh.ai/catalog/standards/iso/7335712c-dd1e-4ac8-89c6-195ad5243f83/iso-1496-1-2013-fdamd-2)

<https://standards.iteh.ai/catalog/standards/iso/7335712c-dd1e-4ac8-89c6-195ad5243f83/iso-1496-1-2013-fdamd-2>

ISO 1496-1:2013/DAM 2:2023(E)

© ISO ~~2023~~2024

All rights reserved. Unless otherwise specified, or required in the context of its implementation, no part of this publication may be reproduced or utilized otherwise in any form or by any means, electronic or mechanical, including photocopying, or posting on the internet or an intranet, without prior written permission. Permission can be requested from either ISO at the address below or ISO's member body in the country of the requester.

ISO copyright office

CP 401 • Ch. de Blandonnet 8

CH-1214 Vernier, Geneva

Phone: +41 22 749 01 11

Email: copyright@iso.org

Website: www.iso.org

Published in Switzerland

iTeh Standards
(<https://standards.iteh.ai>)
Document Preview

ISO 1496-1:2013/FDAmD 2

<https://standards.iteh.ai/catalog/standards/iso/7335712c-dd1e-4ac8-89c6-195ad5243f83/iso-1496-1-2013-fdamd-2>

Foreword

ISO (the International Organization for Standardization) is a worldwide federation of national standards bodies (ISO member bodies). The work of preparing International Standards is normally carried out through ISO technical committees. Each member body interested in a subject for which a technical committee has been established has the right to be represented on that committee. International organizations, governmental and non-governmental, in liaison with ISO, also take part in the work. ISO collaborates closely with the International Electrotechnical Commission (IEC) on all matters of electrotechnical standardization.

The procedures used to develop this document and those intended for its further maintenance are described in the ISO/IEC Directives, Part 1. In particular, the different approval criteria needed for the different types of ISO documents should be noted. This document was drafted in accordance with the editorial rules of the ISO/IEC Directives, Part 2 (see www.iso.org/directives).

~~Attention is drawn~~ISO draws attention to the possibility that ~~some of the elements~~implementation of this document may ~~be involve~~ the ~~subject~~use of (a) patent(s). ISO takes no position concerning the evidence, validity or applicability of any claimed patent rights in respect thereof. As of the date of publication of this document, ISO had not received notice of (a) patent(s) which may be required to implement this document. However, implementers are cautioned that this may not represent the latest information, which may be obtained from the patent database available at www.iso.org/patents. ISO shall not be held responsible for identifying any or all such patent rights. ~~Details of any patent rights identified during the development of the document will be in the Introduction and/or on the ISO list of patent declarations received (see www.iso.org/patents).~~

Any trade name used in this document is information given for the convenience of users and does not constitute an endorsement.

For an explanation ~~on~~of the voluntary nature of standards, the meaning of ISO specific terms and expressions related to conformity assessment, as well as information about ISO's adherence to the World Trade Organization (WTO) principles in the Technical Barriers to Trade (TBT), see the following URL: www.iso.org/iso/foreword.html.

This document was prepared by Technical Committee ISO/TC 104, Freight containers, Subcommittee SC-1, General purpose containers.

A list of all parts in the ISO 1496 series can be found on the ISO website.

Any feedback or questions on this document should be directed to the user's national standards body. A complete listing of these bodies can be found at www.iso.org/members.html.

Field Code Changed

**Series 1 freight containers — Specification and testing —
Part 1: General cargo containers for general purposes —
Amendment 2**

5.3.6

Replace with the following:

~~5.3.6~~—1EEE and 1EE units shall have recesses longitudinally outboard of each of their fittings in the 1AAA/1AA/1A positions. These recesses shall extend vertically to permit full access to the outboard aperture of the fittings in the 1AAA/1AA/1A position, shall extend longitudinally from the longitudinal outward faces of the fittings in the 1AAA/1AA/1A position outboard, to not less than 150 mm from the outboard face of the fittings in the 1AAA/1AA/1A position and shall extend laterally from the external width of the container inboard not less than 154 mm.

Figure-1

Replace with the following:

iTeh Standards
(<https://standards.iteh.ai>)
Document Preview

[ISO 1496-1:2013/FDAmD 2](#)

<https://standards.iteh.ai/catalog/standards/iso/7335712c-dd1e-4ac8-89c6-195ad5243f83/iso-1496-1-2013-fdamd-2>

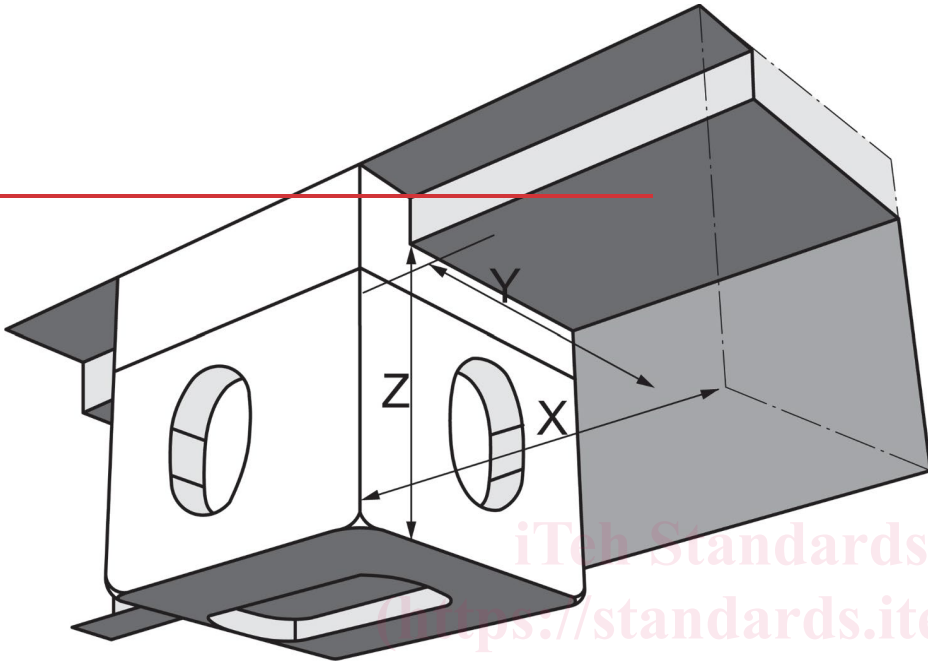

iTech Standards
<https://standards.iteh.ai>
Document Preview

