



Designation: D5579 – 13

# Standard Test Method for Evaluating the Thermal Stability of Manual Transmission Lubricants in a Cyclic Durability Test<sup>1</sup>

This standard is issued under the fixed designation D5579; the number immediately following the designation indicates the year of original adoption or, in the case of revision, the year of last revision. A number in parentheses indicates the year of last reapproval. A superscript epsilon ( $\epsilon$ ) indicates an editorial change since the last revision or reapproval.

## 1. Scope\*

1.1 This test method covers the thermal stability of fluids for use in heavy duty manual transmissions when operated at high temperatures.

1.2 The lubricant performance is measured by the number of shifting cycles that can be performed without failure of synchronization when the transmission is operated while continuously cycling between high and low range.

1.3 Correlation of test results with truck transmission service has not been established. However, the procedure has been shown to appropriately separate two transmission lubricants, which have shown satisfactory and unsatisfactory field performance in the trucks of one manufacturer.

1.4 Changes in this test method may be necessary due to refinements in the procedure, obsolescence of parts, or reagents, and so forth. These changes will be incorporated by Information Letters issued by the ASTM Test Monitoring Center (TMC).<sup>2</sup> The test method will be revised to show the content of all the letters, as issued.

1.5 The values stated in inch-pound units are to be regarded as standard. The values given in parentheses are mathematical conversions to SI units that are provided for information only and are not considered standard.

1.5.1 *Exception*—When materials, products, or equipment are available only in inch-pound units, SI units are omitted.

1.6 *This standard does not purport to address all of the safety concerns, if any, associated with its use. It is the responsibility of the user of this standard to establish appropriate safety and health practices and determine the applicability of regulatory limitations prior to use.*

1.7 This test method is arranged as follows:

|  | Section  |
|--|----------|
| Scope  | 1        |
| Referenced Documents   | 2        |
| Terminology  | 3        |
| Summary of Test Method   | 4        |
| Significance and Use   | 5        |
| Apparatus  | 6        |
| Test Transmission  | 6.2      |
| Transmission Mounts  | 6.3      |
| Oil-Circulating System   | 6.4      |
| Oil Return Hole  | 6.5      |
| Air Pressure Controls  | 6.6      |
| Drive System   | 6.7      |
| Instrumentation  | 6.8      |
| Thermocouple Placement   | 6.9      |
| Reagents and Materials   | 7        |
| Safety   | 8        |
| Preparation of Apparatus   | 9        |
| Cleaning of Parts  | 9.1      |
| Assembly   | 9.2      |
| Calibration  | 10       |
| Transmission and Test Stand Calibration  | 10.1     |
| Reference Oils   | 10.2     |
| Reference Oil Test Frequency   | 10.3     |
| Instrumentation Calibration  | 10.4     |
| Shift Time Calibration   | 10.5     |
| Operating Procedure  | 11       |
| System Flush and Charge  | 11.1     |
| Test Operation   | 11.2     |
| Shut-Down Procedure  | 11.3     |
| Transmission Disassembly   | 11.4     |
| Determination of Test Results  | 12       |
| Failure Criteria   | 12.1     |
| Shifter Fork Wear  | 12.2     |
| Test Validity Determination  | 12.3     |
| Report   | 13       |
| Precision and Bias   | 14       |
| Keywords   | 15       |
| Test Validity Calculations and Limits  | Annex A1 |
| HTCT Test Report Forms and Data Dictionary   | Annex A2 |
| Manual Transmission Cyclic Durability Test Parts<br>Inspection and Wear Measurements | Annex A3 |

## 2. Referenced Documents

### 2.1 ASTM Standards:<sup>3</sup>

- D235 Specification for Mineral Spirits (Petroleum Spirits) (Hydrocarbon Dry Cleaning Solvent)
- D7422 Test Method for Evaluation of Diesel Engine Oils in

<sup>1</sup> This test method is under the jurisdiction of ASTM Committee D02 on Petroleum Products, Liquid Fuels, and Lubricants and is the direct responsibility of Subcommittee D02.B0.03 on Automotive Gear Lubricants & Fluids.

Current edition approved Oct. 1, 2013. Published October 2013. Originally approved in 1994. Last previous edition approved in 2012 as D5579 – 12a. DOI: 10.1520/D5579-13.

<sup>2</sup> ASTM Test Monitoring Center, 6555 Penn Ave., Pittsburgh, PA 15206-4489. This edition incorporates revisions in all Information Letters through No. 13–1.

<sup>3</sup> For referenced ASTM standards, visit the ASTM website, www.astm.org, or contact ASTM Customer Service at service@astm.org. For *Annual Book of ASTM Standards* volume information, refer to the standard's Document Summary page on the ASTM website.

\*A Summary of Changes section appears at the end of this standard

T-12 Exhaust Gas Recirculation Diesel Engine  
**E29 Practice for Using Significant Digits in Test Data to  
 Determine Conformance with Specifications**

2.2 *SAE Standard:*

**SAE J308 Axle and Manual Transmission Lubricants**<sup>4</sup>

2.3 *Military Standard:*

**MIL-L-2105 Lubricating Oil, Gear, Multipurpose**<sup>5</sup>

2.4 *Other Standard:*

**GO-H Mack Trucks Oil, Gear: Multi-Purpose**<sup>6</sup>

### 3. Terminology

3.1 *Definitions:*

3.1.1 *wear, n*—the loss of material from a surface, generally occurring between two surfaces in relative motion, and resulting from mechanical or chemical action or a combination of both. **D7422**

3.2 *Definitions of Terms Specific to This Standard:*

3.2.1 *dual-range transmission, n*—a type of transmission in which the driver first shifts through all of the mainbox gear ratios in low range, and then shifts to high range and shifts through the mainbox again. The section containing the high-low range is the compound section.

3.2.2 *friction disk, n*—a steel circular plate to which a friction material has been bonded.

3.2.3 *glazed, adj*—the condition of the friction disks when precipitates have filled the pores in the friction material, polishing the surface, and changing the frictional properties.

3.2.4 *reaction disk, n*—a steel disk that mates with the friction disk during synchronization.

3.2.5 *shift time, n*—the period of time required, when shifting from high range to low range, for the countershaft speed to increase from (500 to 1700) r/min; or when shifting from low range to high range, for the countershaft speed to decrease from (1700 to 500) r/min.

3.2.6 *synchronizer, n*—a pack of friction and reaction plates used to match the speeds of the low- and high-range gears prior to engagement.

3.2.7 *unsynchronized shift, n*—a shift in which the speed of the mating gears is not matched to the speed of the transmission output shaft by the synchronizer.

### 4. Summary of Test Method

4.1 Prior to each test run, the transmission is disassembled and all parts, including the case and the oil-circulating and heating systems, are thoroughly cleaned. The transmission is rebuilt with a new synchronizer assembly, including measured shifter fork, friction, and reaction disks. All other worn or defective parts are replaced.

4.2 The rebuilt transmission is installed on a test stand.

<sup>4</sup> Available from Society of Automotive Engineers (SAE), 400 Commonwealth Dr., Warrendale, PA 15096-0001.

<sup>5</sup> Available from Standardization Documents Order Desk, DODSSP, Bldg. 4, Section D, 700 Robbins Ave., Philadelphia, PA 19111-5098.

<sup>6</sup> Available from Volvo Powertrain, North America, 13302 Pennsylvania Ave., Hagerstown, MD 21742.

4.3 The transmission and oil system are flushed with the test oil in accordance with the flush procedure.

4.4 The flush oil is drained, and the test oil is measured and charged to the transmission.

4.5 The transmission is started and operated in low range until the oil temperature reaches the test operating range.

4.6 The transmission is automatically cycled between low and high range until two unsynchronized shifts occur or the desired length of test is reached without failure. The time required to shift from high range to low range is recorded each hour.

4.7 At the conclusion of the test, the test parts are removed and visually inspected. The shifter fork and friction plates are measured again to determine wear.

### 5. Significance and Use

5.1 This test method is used to evaluate automotive manual transmission fluids for thermal instability, which results in deterioration of synchronizer performance.

5.2 This test method may also be utilized in other specifications and classifications of transmission and gear lubricants such as the following:

5.2.1 (final API designation of PG-1),

5.2.2 Military Specification MIL-L-2105,

5.2.3 SAE Information Report J308 Axle and Manual Transmission Lubricants, and

5.2.4 Mack Truck GO-H Gear Lubricant Specification.

### 6. Apparatus

6.1 **Table 1** is a list of the make and model of recommended instruments and equipment.

6.2 *Test Transmission*—The test transmission is a MACK T2180, configuration 11KBA51431 (see **Fig. 1**). Some parts in the transmission are to be removed and some are to be added before testing, as listed in **Table 2**. The main box shift rail cover can be replaced with an aluminum plate to facilitate transmission cleaning at end of test.

6.3 *Transmission Mounts*—The transmission is mounted as shown in **Fig. 2**.

6.4 *Oil-Circulating System*—The system heats the oil to the specified operating temperature of  $250 \pm 5^\circ\text{F}$  ( $121^\circ\text{C} \pm 2.7^\circ\text{C}$ ) and maintains this temperature throughout the duration of the test. The power density of the heater is not high enough to cause degradation of the oil (22 to 25 W/in.<sup>2</sup> (3.4 W/cm<sup>2</sup> to 3.9 W/cm<sup>2</sup>)). The oil flow rate is between 6 and 10 gal/min (23 L/min to 38 L/min). A layout of the oil-circulation system is shown in **Fig. 3**. A detailed drawing of the recommended oil heating chamber is shown in **Fig. 4**. The total oil capacity of the test system is 5.25 gal (19.87 L) with the oil level in the transmission at the lower edge of the fill hole. If the system capacity is too small, increase by lengthening oil hoses. When the system capacity is too great, decrease by shortening hoses, if it is practical to do so; otherwise, install an inert (stainless steel) block in the transmission main box sump to raise the oil level. Route the oil lines so that they will empty completely when draining the system.

**TABLE 1 Recommended Test Stand Components**

| Item                        | Manufacturer       | Part No.                        |
|-----------------------------|--------------------|---------------------------------|
| Panel Meters                |                    |                                 |
| Tailshaft rpm               | Newport            | P-6031D20D                      |
| Countershaft rpm            | Newport            | P-6031D20D                      |
| Shift time                  | Newport            | P-6031D20D                      |
| Coast down time             | Newport            | P-6031D20D                      |
| Control Indication          |                    |                                 |
| Temperature controller      | Omron              | ESEX-AF                         |
| Temperature indicator       | Newport            | INF-0-0-0-0-JF                  |
| Cycle counter               | Redington          | P2-1006-115AC                   |
| Cycle timer                 | Omron              | H5BR-B-AC100-240                |
| T/C selector switch         | Thermo Electric    | 33112                           |
| Oil psi gage/safety         | Murphy             | A-20EO, 0-30 psi                |
| Air supply gage             | U.S. Gage          | P44U, 0-160 psi                 |
| Air regulator               | Norgren            | RO-8-300 RNMA                   |
| Shift solenoid              | Asco               | 8317G35, 3-way solenoid         |
| Mag. pickup                 | Electro            | 3010AN                          |
| 12 VDC Power supply         | Sola               | SLS-12-017                      |
| Air pressure switch         | Penn               | P61AG-1                         |
| Relays—AC                   | Potter & Brumfield | KUP14A15                        |
| Relays—DC                   | Potter & Brumfield | KUP14D15                        |
| Mechanical Components       |                    |                                 |
| Air lines                   | Mack               | 101AX24R, 3/8 in. OD            |
| Pump                        | Brown & Sharp      | No. 2                           |
| Heater element              | Chromalox          | MOT330A, 220v, 1Ph              |
| Oil lines                   | Aeroquip           | EC-350, No. 12                  |
| U Joint yoke                | Mack               | 1710 Series, 38MU3413M          |
| Drive shaft                 | Rockwell           | 1710 Series, 52 in. collapsed   |
| Drive motor                 | General Electric   | 25-hp Induction Motor, 1760 rpm |
| High-Speed Recording System |                    |                                 |
| Pressure transducers        | Sensotec           | A-5/1034, 0-100 psi             |
| Oscillograph                | Astro-Med          | Dash 4                          |

6.5 *Oil Return Hole*—Drill and tap a hole in the compound case for the oil to return after flowing through the heat exchanger. The location and size of this hole are shown in Fig. 5.

6.6 *Air Pressure Controls*—The transmission is shifted by air pressure applied to alternating sides of the range shift piston. The air pressure is provided by a pilot valve, which is cycled by a solenoid valve at a rate of 5 cpm. These cycles are recorded by a counter, which provides the cycles to mis-shift data for the pass/fail criteria of the test. A typical air control system is shown in Fig. 6.

6.7 *Drive System*—In the truck operation, opposing torques help the synchronizer to complete the shift. In the test stand, the transmission is driven from the rear by an electric motor and belt drive with no loading on the input pinion. The torques, therefore, are not present, and shifting can be delayed. To help the synchronizer shift smoothly without the opposing torque, a vibration in the drive line is intentionally excited. The driveline is set out of phase by rotating the yoke at one end of the shaft with respect to the other by a one spline tooth offset (22°). The transmission output shaft is offset from the shaft of the motor or jack shaft, thereby placing the driveline at an angle. A layout showing the offset of the transmission relative to the jack shaft is shown in Fig. 2.

6.8 *Instrumentation*—Supply sensors and displays, either on the test console or in a data logging computer, as follows:

6.8.1 Oil sump temperature,

6.8.2 Countershaft speed,

6.8.3 Tail shaft speed,

6.8.4 Air pressure (system),

6.8.5 Air pressure (dynamic during shifting), and

6.8.6 Coast down time.

6.9 *Thermocouple Placement*—Transmission sump temperature is measured in the compound section of the transmission with a thermocouple and conventional display equipment. Drill and tap the compound case to accept the thermocouple at a position located along the centerline of the transmission 8.0 in. (203 mm) forward of the back wall of the main case. Position the tip of the thermocouple to extend 1.5 in. (38 mm) into the sump. As a means of ensuring that the oil is not exposed to excessive heat in the heater, place an additional thermocouple to measure the oil temperature leaving the heater as shown in Fig. 7.

## 7. Reagents and Materials

7.1 *Oil*—Approximately 12 gal (45.4 L) of test oil is required. The integrity of the test oil is the responsibility of the oil supplier.

7.2 *Solvent*—Use only mineral spirits meeting the requirements of Specification D235, Type II, Class C for Aromatic Content (0-2% vol), Flash Point (142°F/61 °C, min), and Color (not darker than +25 on Saybolt Scale or 25 on Pt-Co Scale). (**Warning**—Combustible. Health hazard.) Obtain a Certificate of Analysis for each batch of solvent from the supplier.

## 8. Safety

8.1 The following are suggestions of procedures and equipment that may assist in reducing safety hazards. No attempt has been made to address all possible safety problems. The user of this test method is responsible for establishing appropriate safety and health practices.

8.2 The operating of transmission tests can expose personnel and facilities to a number of safety hazards. Only personnel who are thoroughly trained and experienced in transmission testing should undertake the design, installation, and operation of transmission test stands.

8.3 Each laboratory conducting transmission tests should have its test installation inspected and approved by its safety department. Personnel working on the transmissions should be provided with the proper tools, be alert to common sense safety practices, and avoid contact with moving or hot transmission parts, or both. Heavy-duty guards should be installed around the driveline. When the test stand is operating, personnel should be cautioned against working alongside the transmission and drivelines. All oil lines and electrical wiring should be properly routed and grounded, guarded, and kept in good order. Safety masks or glasses should always be worn by personnel working on the transmissions. Loose or flowing clothing, long hair, or other accessories to dress that could become entangled, should not be worn near rotating equipment.

8.4 The external parts of the transmission and the floor area around the transmission should be kept clean and free of oil spills. In addition, the working area should be free of all tripping hazards. In case of injury, no matter how slight, first

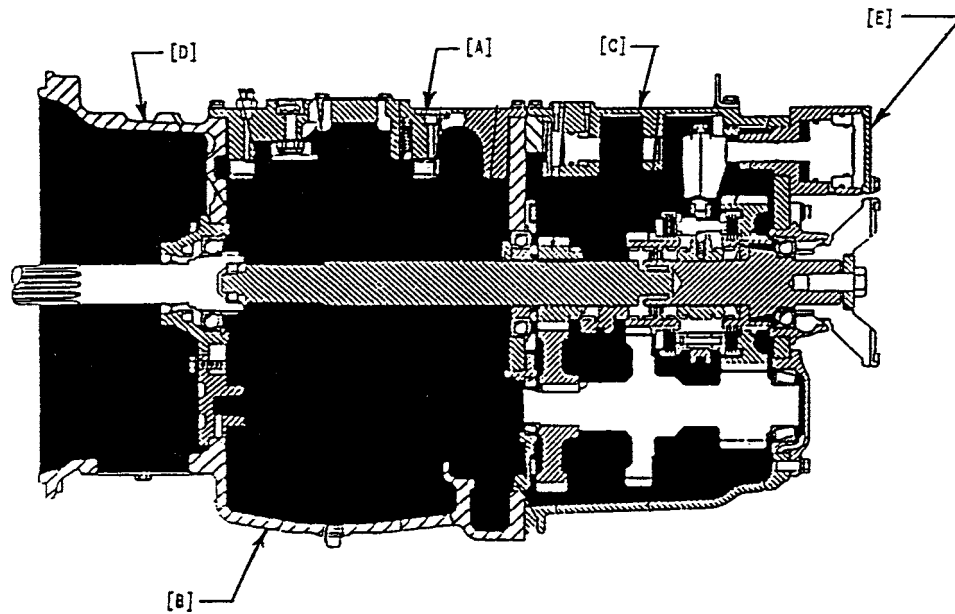

NOTE 1—Left side view.

NOTE 2—See Table 2 for references to letters in brackets.

FIG. 1 Transmission Modified for Testing

TABLE 2 Transmission Parts to Be Added or Removed Before Testing

NOTE 1—Letters in brackets, [ ], refer to locations indicated on Fig. 1.

| Parts to Be Removed  |  |   |
|--|--|---|
| Rails, forks, springs, and ball from the mainbox shift cover [A]       |  |   |
| All main box gearing [B]:  |  |   |
| Main shaft gears and thrust washers                                    |  |   |
| Countershaft assemblies  |  |   |
| Sliding clutches   | Mack part numbers 320KB3136<br>(2)320KB3137A | or Volvo part numbers 25101998<br>(2)25503685 |
| Compound [C]   |  |   |
| Splitter clutch  | Mack part number 320KB3141                   |   |
| Splitter piston  | Mack part number 336KC333                    | or Volvo part number 25125890                 |
| Splitter fork  | Mack part number 575KB3378                   | or Volvo part number 25502825                 |
| Bell Housing [D]   |  |   |
| All clutch related parts   |  |   |
| Shafts   | Mack part number 604KC277A,<br>604KC34B      | or Volvo part number 25085391 N/A             |
| Yoke   | Mack part number 301KD43B                    | or Volvo part number 25128328                 |
| Parts to Be Added  |  |   |
| Speedometer plug   | Mack part number 37KC12                      | or Volvo part number N/A                      |
| Speedometer washer   | Mack part number 37AX419                     | or Volvo part number 20704759                 |
| Orifice to range valve   | Mack part number 63AX3466                    | or Volvo part number 25107528                 |
| Replace cast iron piston housing cover with fabricated steel cover [E] |  |   |

aid attention should be applied at once and the incident reported. Personnel should be alert for leaking oil, which represents a fire hazard. Do not permit containers of oil to accumulate in the test area.

8.5 A remote station for shutting off the motor, pump, and heater is recommended. Fixed fire-protection equipment should be provided.

8.6 Normal precautions should be taken when using flammable solvents for cleaning purposes. Make sure adequate ventilation is provided and fire-fighting equipment is immediately accessible.

8.7 It is recommended that safeties be provided to shut down the drive motor and oil heater when the following conditions occur:

8.7.1 Oil temperature in transmission sump becomes excessive,

8.7.2 Oil temperature leaving the oil-heating chamber becomes excessive,

8.7.3 Oil-circulating system loses pressure,

8.7.4 Motor over-speeds or under-speeds, and

8.7.5 The fire-protection system is activated.

8.8 See Fig. 8 for a typical schematic of safety circuits.

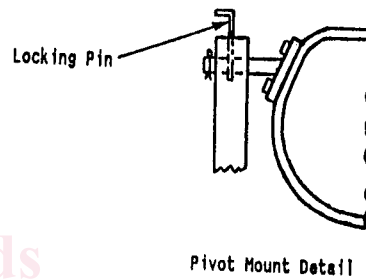
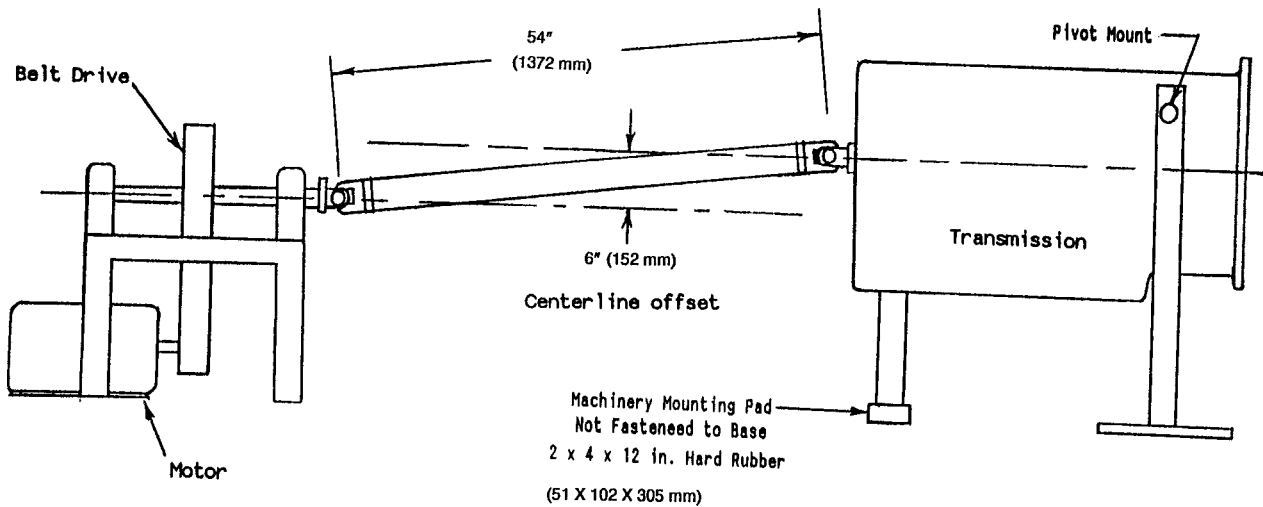

FIG. 2 Typical Layout of Drive System

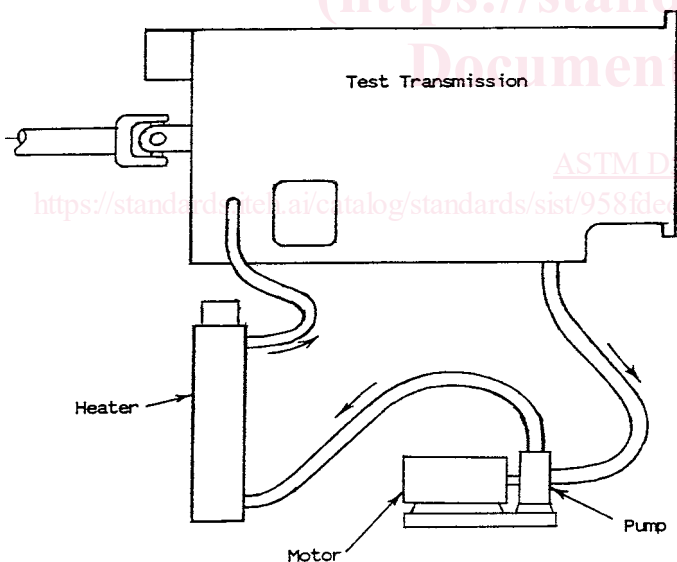

FIG. 3 Schematic of Oil System

9. Preparation of Apparatus

9.1 Cleaning of Parts:

9.1.1 *Transmission Case*—Thoroughly clean the transmission case with a cleaning solvent (see 7.2) to remove any oil, sludge, or varnish deposits remaining from the previous test and then air dry.

9.1.2 *Gears, Shafts, Synchronizer*—Remove all sludge, varnish, and deposits. Rinse with a cleaning solvent (see 7.2) and air dry.

9.1.3 *Heater, Oil-Circulating System*—Flush oil lines with a cleaning solvent (see 7.2) to remove any previous test oil and then air dry. Disassemble the heater, clean, and air dry after each test. Check the heater periodically for leaks and replace when necessary.

9.2 Assembly:

9.2.1 *General*—Assemble all parts as instructed in the Mack Transmission Service Manual T2130/2180,<sup>6</sup> except where the service manual applies to parts that are modified for this test method. Refer to Table 3 for a list of approved test hardware part numbers. Use test oil for lubricating parts during assembly.

9.2.2 *New Parts*—Obtain the following parts from an authorized Mack truck dealer. Install the new parts listed in Table 4 for each test:

9.2.2.1 Inspect the following parts after each test and replace if worn or damaged:

|                            | Number Required | Mack Part No.  | Volvo Part No.                                       |
|----------------------------|-----------------|--|--|
| Thrust Washer              | 3               | 223KD249   | 25500345   |
| Thrust Washer              | 2               | 223KD316A  | 25500919   |
| Clutch Housing             | 2               | 53KC486C   | 25502585   |
| High Range Main Shaft Gear | 1               | 751KB4123 <sup>A</sup><br>or<br>751KB4176 <sup>B</sup> | 25502562 <sup>A</sup><br>or<br>21649207 <sup>B</sup> |

<sup>A</sup> One of the parts required in hardware "CONFIGURATION 2".

<sup>B</sup> One of the parts required in hardware "CONFIGURATION 3".

9.2.3 *Inspection of Air Valves*—Inspect the piston of the range shift valve and the fork air cylinder and replace if damaged or visibly worn. Replace the O-rings in these valves when nicked, cut, softened, or hardened. However, replace

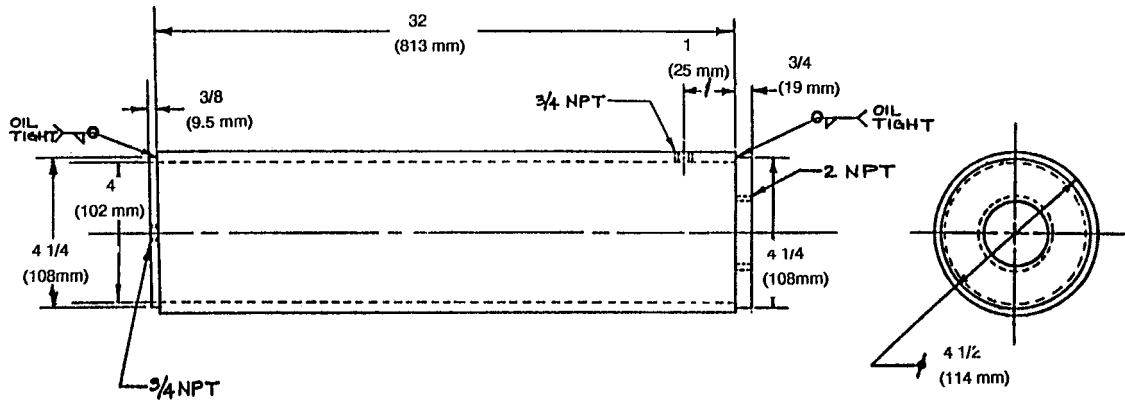

NOTE 1—Material 1018 is similar material.

NOTE 2—All dimensions are in inches, unless otherwise noted.

FIG. 4 Typical Oil Heater Chamber

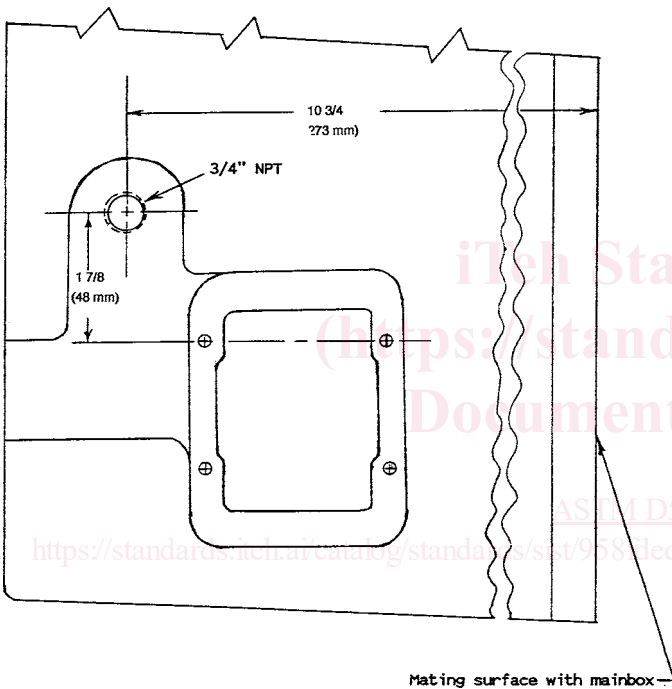

NOTE 1—Figure is not drawn to scale.

FIG. 5 Oil Return Hole Location

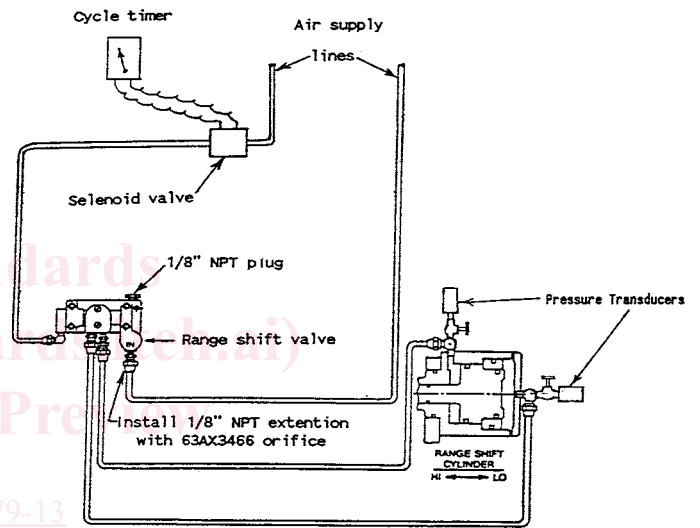

FIG. 6 Air Control and Supply System

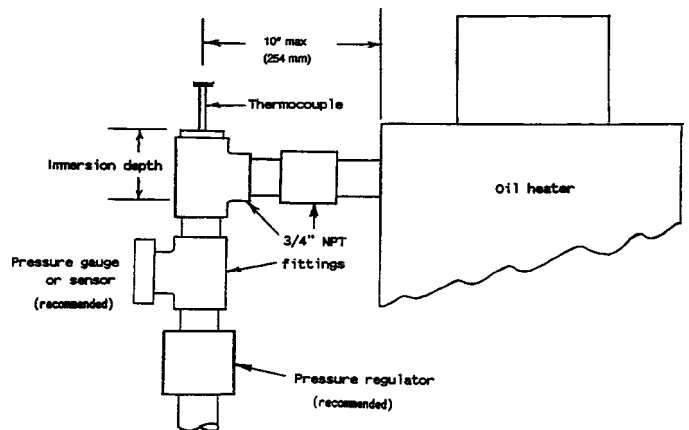

FIG. 7 Location of Oil Out-of-Heater Thermocouple, Pressure Regulator, and Sensor

these O-rings at least every six months. Install a 1/16-in. (1.59 mm) thick shim between the shaft cylinder and the transmission case for “CONFIGURATION 2” and “CONFIGURATION 3” tests.

9.2.4 *Pre-test Measurements*—Measure the range fork for hardness and thickness at the locations shown in Fig. A3.1. The hardness of the fork pads shall be a minimum of 55 R<sub>c</sub> at each of the four locations. Mark the friction disks on the spline tangs with an etching tool at three locations equally spaced. Measure and record the pad thickness at these locations in the Data Dictionary (see Annex A2).

9.2.4.1 This hardness is greater than the manufacturing minimum. Some parts meeting the manufacturing specification may be rejected for this test method.

9.2.5 *Countershaft Bearing Preload*—Measure the pre-load on each of the three countershafts prior to each test as follows:

9.2.5.1 Assemble the transmission as specified in the Mack Transmission Service Manual up to and including installing the yoke on the output shaft. Rotate the transmission so that the shafts are vertical.